



Owner/Operator Manual

TOMAHAWK® Chipper/Shredder

- Safety
- Assembly
- Controls
- Operation
- Maintenance

Models

- 4 HP
- 5 HP
- 8 HP

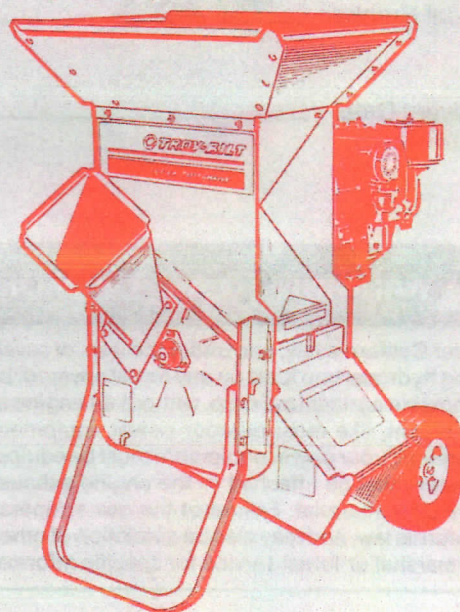

INTRODUCTION

Dear Owner,

Your TROY-BILT® TOMAHAWK® Chipper/Shredder is so ruggedly built and of such high quality, we're sure it will meet, even exceed, your expectations. There are so many things it will do to make gardening, landscaping and property improvement projects truly easier and faster. From making mulches... to compost... to decorative wood chip dressings around plantings... and on and on. You'll find it a pleasure to use too, like all equipment from TROY-BILT.

We've prepared this Owner/Operator Manual to guide you in the proper use of your Chipper/Shredder and we've included a special section on Safety Instructions which we urge you to read completely. Your safety, and the safety of others around you, make the Safety Instructions and the entire Manual "must reading" before you put this equipment to work. There's a section on Maintenance and Service too, so you'll be able to keep your Chipper/Shredder running at peak performance all the time.

Of course, if you have any questions or problems with operation or service, please contact our Technical Service Department right away (see the phone number on the next page). Don't hesitate to ask us for help. We want to do everything we can to make the time you spend using your equipment as productive and as enjoyable as possible.

WE'RE HERE TO SERVE YOU...

The whole idea behind our Factory Service Policy is to provide you with direct access to the parts and service information you may need as quickly as possible, and to answer all questions you may have.

Nothing is more important to all of us here at the Factory than making sure that every customer is completely satisfied at all times. You're always entitled to first-rate service. Please be assured that we will do our very best to see that you receive it.

Thank you,



Dean Leith, Jr., Sales Manager



IMPORTANT — WRITE THE SERIAL NUMBER OF YOUR MACHINE IN THE SPACE PROVIDED BELOW...

To provide fast and efficient service, should you contact us, we'll need to know the SERIAL NUMBER of your Chipper/Shredder. The photo at right shows you where to look to find this number. For ready reference, please record your Serial Number, specific Model ordered, and delivery date below.

Serial Number _____

Model Number 47255

Delivery Date _____

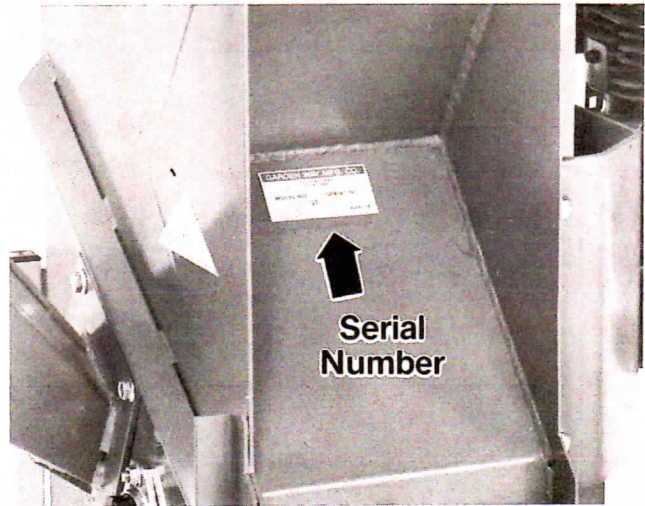

WARNING TO ALL CALIFORNIA AND OTHER POWER EQUIPMENT OPERATORS

Under California law, and under the laws of several other states, you are not permitted to operate an internal combustion engine using hydrocarbon fuels on any forest covered, brush covered, or grass covered land, or on land covered with grain, hay, or other flammable agricultural crop, without an engine spark arrester in continuous effective working order. The engine on your power equipment, like most outdoor power equipment, is an internal combustion engine that burns gasoline, a hydrocarbon fuel. Therefore, your power equipment must be equipped with a spark arrester muffler in continuous effective working order. The spark arrester must be attached to the engine exhaust system in such a manner that flames or heat from the system will not ignite flammable material. Failure of the owner/operator of the equipment to comply with this regulation is a misdemeanor under California law, and may also be a violation of other state and/or federal regulations, laws, ordinances, or codes. Contact your local fire marshal or forest service for specific information about what regulations apply in your area.

Chipper/Shredder Service:

You'll find helpful service and maintenance procedures in this Owner/Operator Manual, so be sure to look here first... all the help you need may be right in the Manual. Just look at the Table Of Contents below for subject areas and page number references.

If you do not find the answers you need in this Manual, please contact us either by letter or phone, whichever you prefer. Remember, we'll need the Serial Number of your equipment to give you the most efficient service possible.

SEND SERVICE LETTERS TO:

Troy-Bilt Mfg. Company	Garden Way Canada, Inc.
c/o Technical Service Dept.	1515 Matheson Blvd.,
102nd St. & 9th Ave.,	Unit B11
Troy, NY 12180	Mississauga, Ontario L4W2P5

OR TELEPHONE:

In the U.S.:

Technical Service: Toll-Free 1-800-833-6990
Parts Sales: Toll-Free 1-800-648-6776

In Canada:

Local only (416 Area Code): 624-8423
From Ontario & Quebec: Toll-Free 1-800-387-3351
From Western Canada and the Maritime Provinces:
Toll-Free 1-800-387-3316

Chipper/Shredder Parts:

For parts only, please write or telephone, using the address or telephone number given at left. Ask for the *Parts Dept.* Before writing or calling, refer to the Parts Listing you received to find out the Part Description and the Part Number of each item you'll be ordering. Be sure to include this information in your letter, or have it on hand if you're calling us.

Engine Service & Repairs:

Please contact your nearest authorized Briggs & Stratton or Tecumseh engine dealer if engine service or repair is needed. This listing is in the phone book "Yellow Pages" under "Engines, Gasoline" or "Gasoline Engines". The Service Outlet will need to know the Model and Serial Number of your engine — Section 5 in this Manual shows you how to locate these numbers.

Your local Briggs or Tecumseh Dealer can handle all repairs, parts orders and warranty service concerning the engine alone. If you wish to contact us before seeing the local Engine Dealer, or if you have difficulty getting engine service or parts locally, be sure to let us know. See the enclosed Engine Manufacturer's literature for full terms of the Limited Warranty on the engine and other details about the engine.

TABLE OF CONTENTS

	Page No.		Page No.
Section 1 — SAFETY INSTRUCTIONS	2-5	Engine Features & Controls:	
		Carburetor Choke	19
		Run-Stop (or On-Off) Control	20
		Recoil Starter	20
		Optional Electric Start	20
		Fuel Tank	20
Section 2 — ASSEMBLY & PREPARATION		Section 4 — OPERATING INSTRUCTIONS	
Inspection After Delivery	6	Materials Recommended For Shredder	21
Parts Checklist	6	Materials Recommended For Chipper	21
Attach Chipper Chute	7	Moving The Chipper/Shredder	22
Belt Tension Check	8	Pre-Starting Steps	22
Add Motor Oil To Engine	8	Engine Starting & Stopping Steps	23
Assemble The Electric Start System	10	Chipper Use	24
		Shredder Use	24
Section 3 — FEATURES & CONTROLS		Section 5 — MAINTENANCE & SERVICE	
Chipper/Shredder Features & Controls:		Engine Maintenance	26-27
Shredder Hopper	15	Chipper/Shredder Maintenance	28-39
Chipper Chute	16	Battery Care	40
Chipper/Shredder Chamber	16	SPECIFICATIONS	Inside Back Cover
(Chipper Blade & Shredder Flails)			
Discharge Tunnel & Screen	17		
Clutch Lever	18		

SECTION 1:

Safety Instructions — IMPORTANT!

1

Safety

DANGER

CONTACT WITH ROTATING CUTTING BLADES INSIDE DISCHARGE OPENING WILL CAUSE SERIOUS PERSONAL INJURY! CUTTING BLADES ARE ROTATING WHILE MACHINE IS RUNNING, AND SLOW DOWN GRADUALLY AFTER ENGINE IS SHUT OFF.

KEEP HANDS, FEET, FACE, AND CLOTHING OUT OF SHREDDER HOPPER INLET AND CHIPPER CHUTE INLET AND AWAY FROM THE DISCHARGE AREA AND MOVING PARTS AT ALL TIMES TO AVOID SERIOUS INJURY. BEFORE DOING MAINTENANCE OR SERVICE, SHUT OFF THE ENGINE, LET ALL MOVING PARTS STOP COMPLETELY, AND DISCONNECT THE SPARK PLUG WIRE.

Please read and follow all of the safety instructions in this safety section. Failure to comply can result in serious personal injury or property damage. If you have questions, or are not completely sure about any of the information found here or elsewhere in this Manual, please call us for assistance before you operate your equipment.

SAFETY BEFORE STARTING THE ENGINE

1. Become familiar with this Owner/Operator Manual before attempting to operate your equipment.
2. Know where the engine shut-off control is and how to use it. On manual start models, this control is a switch on top of the engine. On electric start models, it's a key-operated switch just under the engine.
3. The operation of any powered machine can result in foreign objects being thrown by high speed rotating parts. Always wear work gloves, sturdy footwear and hearing protection while using your equipment. Always wear safety glasses or other eye protection when using the equipment. Do not wear loose-fitting clothing, jewelry, scarves, ties, etc. that can get caught in moving parts.
4. The engine must be OFF and allowed to cool for several minutes before filling the fuel tank with gasoline. Use an approved gas storage container. Gasoline and its vapors are highly flammable and explosive. Keep matches, flame, and smokers' materials far away from fueling area. Fill fuel tank outdoors. Wipe up fuel spills right away.
5. Before starting the engine, make a visual check to see that all screws, nuts, bolts and other fasteners are properly secured. The Discharge Screen must be **securely** in place if being used. It's not needed

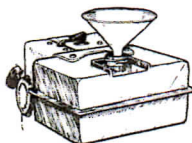
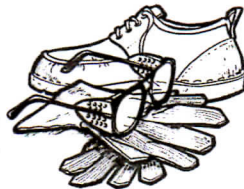
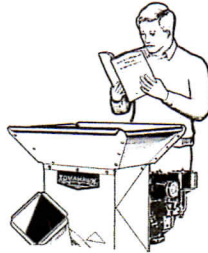

with wet material. Disconnect the spark plug wire before performing this check. **This check is recommended before each usage.**

6. Before operating your equipment, be sure that the chipper chute, shredder hopper and internal cutting chamber are empty, and the service door is securely closed with a rod and hair pin. The engine must be off, all moving parts completely stopped, and the spark plug wire disconnected before you do this.

SAFETY DURING OPERATION

7. Keep hands, feet, face, and clothing out of shredder hopper inlet and chipper chute inlet and away from discharge area and moving parts to avoid serious injury.
8. Keep hands and feet out of discharge opening when machine is running. Rotating cutting blades inside opening will cause serious personal injury.
9. Do not allow children or untrained adults to operate the equipment.
10. Do not run the engine in an enclosed area. Engine exhaust contains carbon monoxide gas, a deadly poison that is odorless, colorless, and tasteless. Do not operate near buildings, windows, or air conditioners.
11. Do not operate your equipment when bystanders or pets are nearby. Keep bystanders at least 25 feet away from this equipment.
12. Do not operate the Chipper/Shredder on a paved or gravel surface. Discharged material may bounce from a hard surface and cause personal injury. Select a level, earthen surface.

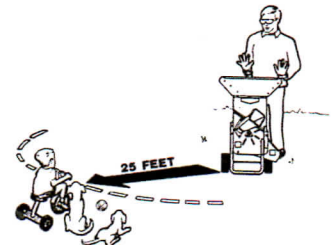
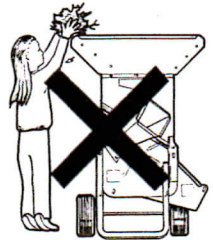

13. Always stand clear of the Discharge Area when operating your equipment. The correct "Zone of Operation" is shown in the sketch nearby. Stand in the "Zone" when operating your equipment.

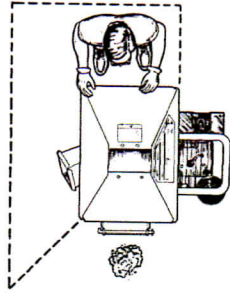

14. Do not put face, hands, feet, or any part of your body or clothing near the Chipper Chute, Shredder Hopper, or Discharge Area. Cutting blades will begin to rotate and build up speed once the engine is running and Clutch Lever is moved Down. **Once blades are revolving, moving the Clutch Lever Up will NOT stop the blades! To stop blade motion, shut off engine while Clutch Lever is in Down position. Important — after engine is shut off, cutting blades slow down GRADUALLY.** Under normal shut-down circumstances (engine shut off and stopped, with Clutch Lever in Down position), rotating blades will require from 30-to-45 seconds to stop completely. If engine is shut off and Clutch Lever were Up (or the belt broke or slipped off a pulley), the rotating blades will require 90-to-120 seconds, or longer, to stop. Don't assume blades have stopped! Be sure! Look at the end of the drive shaft (next to the Chipper Chute) to verify it's motionless. Look for the white paint mark on the bearing. Injury can occur unless blades are completely stopped.

15. If Chipper or Shredder becomes jammed or clogged, shut the engine off and move the Clutch Lever Up (normal stopping procedure is to leave the Clutch Lever Down) to prevent damage to Chipper/Shredder parts. To avoid injury, **make sure all moving parts have come to a complete stop!** Disconnect the spark plug wire. Only then inspect the shredder hopper, chute, the discharge screen, and the internal chamber. **Remember — rotating blades can take from 90-to-120 seconds or longer to stop after the engine is off!** Use only a wooden stick to clear away jammed material.

16. When feeding appropriate material into the Chipper or Shredder, be extremely careful that pieces of metal, rocks, bottles, nails, cans and any other foreign objects are not included. Please use organic materials only!

17. Shut off the engine immediately and move the Clutch Lever Up if the Chipper/Shredder strikes any foreign object or develops any unusual noises or vibrations. **Make sure all moving parts have stopped completely!** Then, disconnect the spark plug wire from the spark plug and take the following steps:

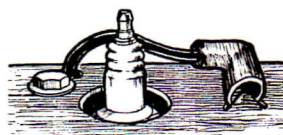

- a. Inspect for damage; b. If a foreign object is present, remove it; c. Check for loose parts or hardware, and tighten if loose; d. Replace or repair damaged parts.

18. Do not allow the engine, especially around the cooling fins and muffler, to become clogged with leaves, oil, grease or any other combustible material. Keep these areas clean to avoid a potential fire hazard.

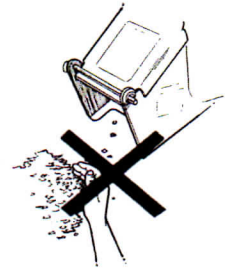

19. Do not allow chipped or shredded material to build up in, or clog, the Discharge Tunnel or opening — clogging prevents proper discharge of materials and can result in kickback of material through the Shredder Hopper or Chipper Chute. In order to remove material from the discharge area, use a long-handled shovel or long stick. **Never use your hands or feet!** Blades cut 1/4-inch from Discharge Screen. Keep away! **Never put your hands or feet in the discharge opening.**

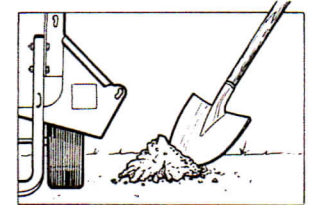

20. Keep all safety shields, guards, screens and deflectors securely in place and in good condition. **Do not operate the unit unless the Chipper Chute and Discharge Tunnel are bolted in place, and the Service Door is closed with a rod and hair pin.**

21. Do not overreach when feeding material into the Hopper or Chute. Keep proper footing and good balance at all times. **Arms should be parallel to the ground**

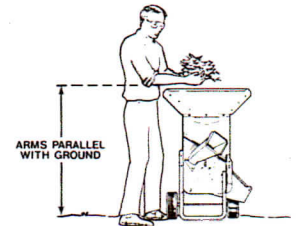

- when shredding materials; when chipping, keep arms perpendicular to the Chipper Chute.** Obey the safety and instruction decals on your equipment at all times.

22. Do not transport or move your equipment while the engine is running.

23. Do not tamper with the governor setting on the engine. The governor controls the maximum safe operating speed and protects the engine and other moving parts from damage that can be caused by engine overspeeding.

SAFETY INSTRUCTIONS FOR MAINTENANCE AND STORAGE

24. Before service, maintenance, cleaning, inspection, changing Shredder Discharge Screens or work of any other kind is to be done, be sure the engine is stopped, all moving parts are still, and the spark plug wire is disconnected. If the engine had been running, allow the hot muffler to cool before working near it or installing a storage cover.

25. Store this equipment where children will not have access to it. Always disconnect the spark plug wire.

26. Be sure the Chipper/Shredder is stored in an area where any gasoline vapors (fumes) from the engine cannot reach an open flame, sparks, or flame-producing equipment such as a hot water heater pilot light, a woodstove, or a furnace.

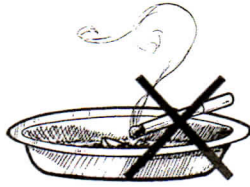

27. For seasonal storage, drain all gasoline from the fuel tank and dispose of it in a safe manner. Then run the engine until the small amount of gasoline left in the carburetor and fuel line has been used up. Disconnect the spark plug wire. Let the engine cool before storing.

MAKE SURE THE SAFETY DECALS ON YOUR EQUIPMENT ARE KEPT CLEAN AND IN GOOD CONDITION SO YOU CAN FOLLOW THE INSTRUCTIONS ON THEM! SHOULD YOU NEED REPLACEMENT DECALS, PLEASE CONTACT US FOR THE ONE YOU NEED — AT NO COST. REFER TO YOUR SEPARATE PARTS CATALOG FOR INDIVIDUAL PART NUMBERS.

- #1. This decal appears once on the service door of your equipment.
- #2. This decal is used once on the side of your equipment opposite the service door. It is next to the hole where the screen tab appears when the discharge screen is installed.

#1

! DANGER

ROTATING CUTTING BLADES.
TO AVOID SERIOUS INJURY WHILE MACHINE IS RUNNING:

- KEEP HANDS AND FEET OUT OF DISCHARGE OPENING!
- KEEP AWAY FROM DISCHARGE AREA!
- KEEP THIS SERVICE DOOR SECURED WITH ROD AND HAIR PIN!

#2

! DANGER

ROTATING CUTTING BLADES WILL CAUSE SERIOUS PERSONAL INJURY!

KEEP FINGERS AND HANDS OUT OF OPENINGS AT ALL TIMES.

- #3. This decal is just above the Service Door.
- #4. This decal appears twice on your machine: once in the shredder hopper and once in the chipper chute. (On 4HP Models, there is a special down-sized version in the smaller chipper chute.)
- #5. Look for this decal in two locations; once on each side of the discharge tunnel.
- #6. This decal appears right under the chipper chute.
- #7. This decal appears next to the clutch lever — it's on the engine mounting plate.
- #8. You'll see this decal by looking underneath the engine — it's on the belt cover.
- #9. This is the Operating Instructions decal. It is located in the shredder hopper.
- #10. This decal is located just above the engine on the steel wall.

#3

! DANGER

ROTATING CUTTING BLADES! DO NOT OPERATE UNLESS DISCHARGE TUNNEL IS BOLTED IN PLACE.

#4

! DANGER

ROTATING CUTTING BLADES.

KEEP HANDS AND FEET OUT OF INLET AND DISCHARGE OPENINGS WHILE MACHINE IS RUNNING TO AVOID SERIOUS PERSONAL INJURY.

NO HANDS BELOW THIS LINE

#5

! DANGER

ROTATING CUTTING BLADES WILL CAUSE SERIOUS PERSONAL INJURY.

KEEP HANDS AND FEET OUT OF DISCHARGE OPENING AND AWAY FROM DISCHARGE AREA.

⚠ DANGER
 ROTATING CHIPPER
 BLADE WILL CAUSE
 SERIOUS PERSONAL
 INJURY. DO NOT
 OPERATE UNLESS
 CHIPPER CHUTE IS
 BOLTED IN PLACE.

#6

IMPORTANT

- Read the Owner/Operator Manual before starting and using this equipment. If you need a replacement Manual or decal, contact Troy-Bilt Mfg. Co., 102nd St. & 9th Ave., Troy, NY 12180.
- Keep hands, feet, face and clothing out of shredder hopper inlet and chipper chute inlet and away from discharge area and moving parts to avoid serious injury.
- Keep hands and feet out of discharge opening when machine is running. Rotating cutting blades inside opening will cause serious personal injury.
- Wear approved safety glasses, gloves, and ear protection. Avoid wearing loose fitting clothing.
- Keep bystanders, children, and pets away from operating and discharge areas.
- If unit jams or becomes clogged, shut engine off right away and let all

moving parts come to a complete stop. Disconnect the spark plug wire. Use only a wooden stick to clear away discharged material or blockages.

- Keep all shields and service door in place and securely attached.
- DO NOT use hands or feet to clear material from the discharge area.
- DO NOT install parts, or remove, adjust or service the discharge screen or any other part while machine is running. DO NOT operate unit on uneven ground, or on a paved, gravel or hard surface. DO NOT run engine in an enclosed area—exhaust gas contains poisonous carbon monoxide fumes.

⚠ WARNING
 TO AVOID A FIRE HAZARD, KEEP LEAVES, GRASS AND OTHER COMBUSTIBLE MATERIALS AWAY FROM HOT ENGINE AND MUFFLER!

⚠ DANGER
 Once Blades Are Rotating, Moving The
 Clutch Lever Up Will NOT Stop Blade
 Motion!
 To Stop Blade Motion, Shut Engine Off
 While Clutch Lever Is Down. Blades
 Slow Gradually. Allow All Moving Parts
 To Stop Completely.
 Contact With Moving Blades Will
 Cause Serious Personal Injury.

#7

TROY-BILT® SUPER TOMAHAWK® 2 IN 1 CHIPPER/SHREDDER
OPERATING INSTRUCTIONS

BEFORE STARTING:

- The Discharge Screen must be correctly and securely installed with rods and hair pins before shredding dry material (refer to Owner/Operator Manual for screen installation procedure).
- Be sure the Service Door is securely closed with a rod and hair pin.

TO START:

- Move engine Choke Lever to "full choke" position. If engine has already been running, do not use Choke Lever.
- Move On-Off Switch (Briggs & Stratton engines) to "On" position or Run-Stop switch (Tecumseh engines) to "Run" position. (Does not apply to electric-start models.)
- Move Clutch Lever all the way UP.
- Pull Start Rope out firmly to start engine. On Electric Start models, turn Key to "Start" position. Move Choke Lever to "Partial" choke position once engine starts. After a few seconds, move lever to "No Choke" position.
- Swing Clutch Lever down slowly to transfer power to the internal rotating cutting blades.

TO STOP:

- Move On-Off Switch to "Off" or the Run-Stop Switch to "Stop" position. On electric-start models, turn key to "Off".
- Keep Clutch Lever "Down" until all moving parts have come to a complete stop.

#9

⚠ WARNING
 DO NOT START ENGINE UNLESS BELT
 COVER IS ATTACHED. Failure to Comply
 Could Result in Personal Injury From Moving
 Belt And Pulleys. See Owner's Manual For
 Full Safety And Maintenance Instructions.

#8

⚠ WARNING
 TO AVOID A FIRE HAZARD, KEEP LEAVES, GRASS AND OTHER COMBUSTIBLE MATERIALS AWAY FROM HOT ENGINE AND MUFFLER!

#10

⚠ DANGER

THE ROTATING SHREDDER CUTTING BLADES INSIDE THE DISCHARGE OPENING CUT 1/4" FROM THE DISCHARGE SCREEN. CONTACT WITH ROTATING CUTTING BLADES WILL RESULT IN SERIOUS PERSONAL INJURY. KEEP HANDS AND FEET OUT OF DISCHARGE OPENING AND AWAY FROM DISCHARGE AREA WHEN MACHINE IS RUNNING, AND WHILE BLADES ARE COASTING TO A STOP.

IN ORDER TO REMOVE CHIPPED OR SHREDDED MATERIAL FROM THE DISCHARGE AREA, USE A LONG-HANDLED SHOVEL OR LONG STICK — NEVER USE YOUR HANDS OR FEET!

IF MATERIAL SHOULD EVER CLOG THE CHAMBER, DISCHARGE TUNNEL, OR DISCHARGE OPENING, SHUT OFF THE ENGINE, LET ALL MOVING PARTS STOP COMPLETELY, AND DISCONNECT THE SPARK PLUG WIRE. USE A STICK TO CLEAR THE CLOGGED MATERIAL.

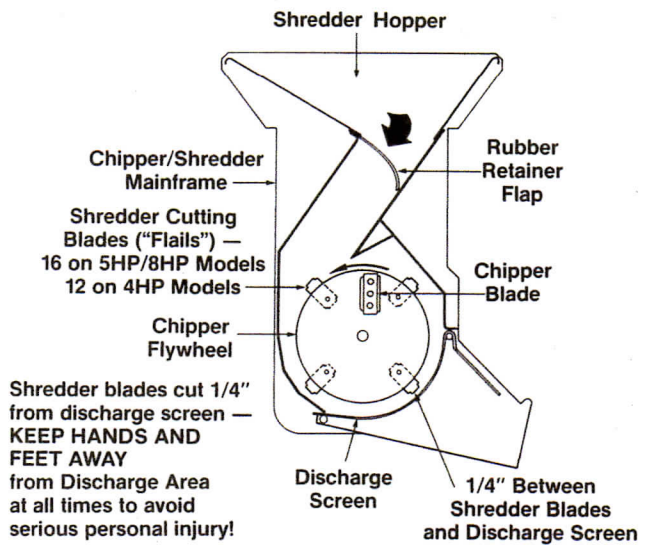

Shredder blades cut 1/4" from discharge screen — KEEP HANDS AND FEET AWAY from Discharge Area at all times to avoid serious personal injury!

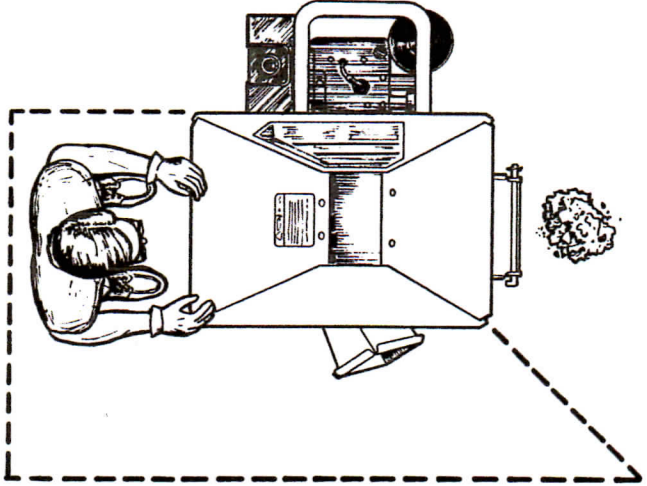

OPERATION ZONE

SECTION 2:

Easy Assembly & Preparation

Now that your TROY-BILT® SUPER TOMAHAWK® Chipper/Shredder has arrived, you'll find it's easy to get your machine ready for operation. Be sure to carefully follow all of the assembly and preparation steps that apply to your particular model!

IMPORTANT — Motor oil must be added to the engine before it is started. The procedure for adding oil is explained in Step 5 of these instructions. Do not operate your equipment until you have read this Owner/Operator Manual completely.

STEP 1: Inspection After Delivery

Inspect your equipment immediately after it has been delivered. Make sure that neither the carton nor the contents have been damaged. If you find or suspect any damage, contact the trucking company (carrier) right away. Inform them of the specific damage and that you wish to file a claim. To protect your rights, be sure to put this in writing to the carrier within 15 days after your machine has arrived. The carrier will let you know how to proceed with a claim. Of course, if you need any assistance, be sure to let us know.

STEP 2: Unpacking Instructions

For shipping purposes, the chipper/shredder is shipped on its side. To unpack your chipper/shredder, please proceed as follows:

- a. Open top of carton and remove as many loose parts (see Step 2-c) as you can reach.

IMPORTANT: The machine weighs over 200 pounds. To help prevent possible injury, we recommend that you have someone assist you in completing the next step.

- b. With someone assisting you, gently tilt the carton upright so that the machine is resting on its wheels and axle stand. Once the machine is upright, you can easily move it by following the "Transporting the Chipper/Shredder" instructions on Page 22.

- c. Remove the following loose parts:

- One Chipper Chute (see Photo 2-1).
- One Leaf Tamper (see Photo 2-1).
- One parts/hardware package (see "Common Parts/Hardware List" to the right).
- One battery and one parts/hardware package for electric start models (see either "5HP Model Electric Start Parts/Hardware List" or "8HP Model Electric Start Parts/Hardware List" on Page 7).

IMPORTANT: If you are missing any parts, please contact your local servicing dealer or call the Factory (see Page 1 for how to obtain assistance).

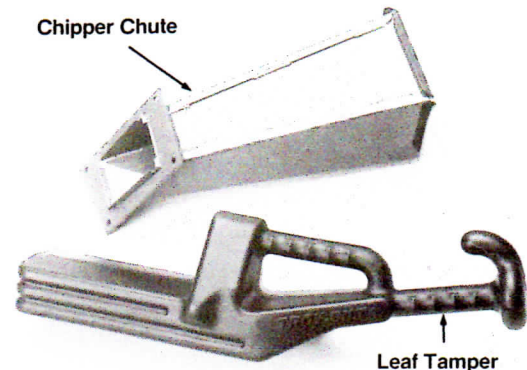

(Photo 2-1) Remove Chipper Chute and Leaf Tamper from shipping container.

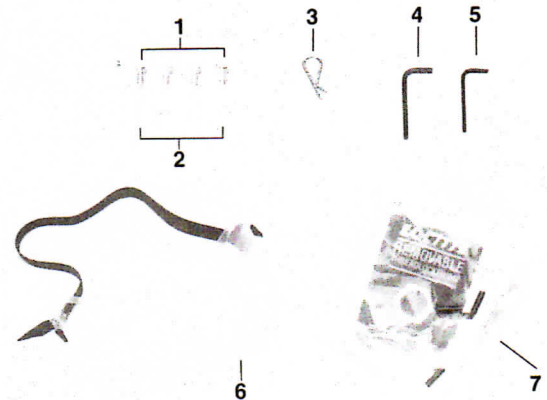

(Photo 2-2) The parts shown above are supplied with all chipper/shredder models.

COMMON PARTS/HARDWARE LIST

The following parts are supplied with all chipper/shredder models (see Photo 2-2). Note that the Maintenance Roll Pin Kit (Ref. No. 7) is included in the package that contained this Owner/Operator Manual.

Photo Ref. No.	Item Description	Qty.
1	Hex Hd. Screw, 5/16"-18 x 5/8"	4
2	Lockwasher, 5/16"	4
3	* Hairpin Clip (for securing discharge screen — keep as a spare)	1
4	* Hex Key Wrench, 5/32" (for chipper blade service, as required)	1
5	* Hex Key Wrench, 1/8" (for bearing locking collar service, as required)	1
6	* Safety Goggles	1
7	* Maintenance Roll Pin Kit (for shredder cutting blades service, as required)	1
	* Not required for assembly	

2

Easy Assembly

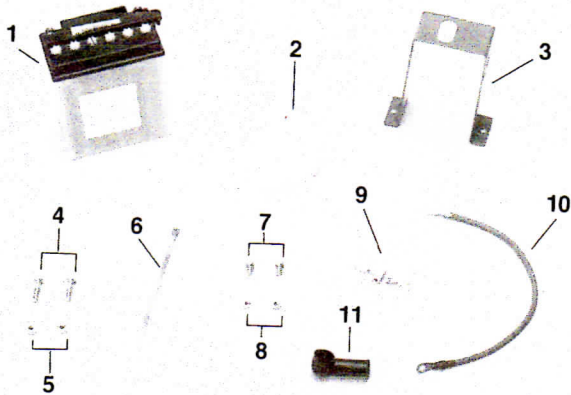

(Photo 2-3) The parts shown above are supplied with 5HP electric start models only.

5HP ELECTRIC START PARTS/HARDWARE LIST

The following parts are supplied with 5HP electric start chipper/shredder models only (see Photo 2-3).

Photo Ref. No.	Item Description	Qty.
1	Battery (must be activated and charged)	1
2	Vent Tube	1
3	Hold-Down Clamp	1
4	Hex Hd. Screw, 1/4"-20 x 1"	2
5	Hex Locknut, 1/4"-20	2
6	Wire Tie, plastic	1
7	Hex Hd. Screw, Phillips, M6 x 1 x 12 mm (metric)	2
8	Hex Nut, M6 x 1 (metric)	2
9	Ignition Key (keep one as a spare)	2
10	Battery Cable, 14"	1
11	Cable Boot	1

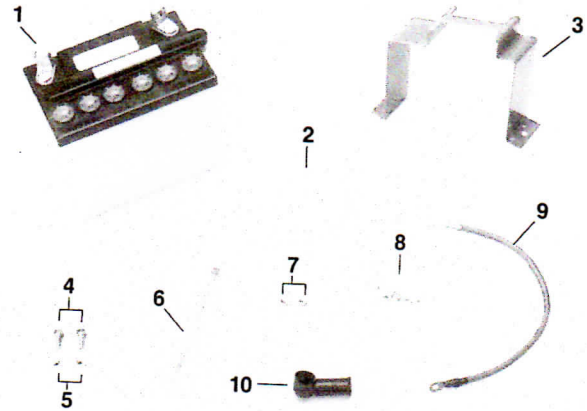

(Photo 2-4) The parts shown above are supplied with 8HP electric start models only.

8HP ELECTRIC START PARTS/HARDWARE LIST

The following parts are supplied with 8HP electric start chipper/shredder models only (see Photo 2-4).

Photo Ref. No.	Item Description	Qty.
1	Battery (must be activated and charged)	1
2	Vent Tube	1
3	Hold-Down Clamp	1
4	Hex Hd. Flange Screw, 1/4"-20 x 5/8"	2
5	Hex Nut, 1/4"-20	2
6	Wire Tie, plastic	1
7	Hex Locknut, 1/4"-20	2
8	Ignition Key (keep one as a spare)	2
9	Battery Cable, 14"	1
10	Cable Boot	1

STEP 3: Attach Chipper Chute

Follow these directions to attach the Chipper Chute to the side of your equipment opposite the engine.

Align the four holes at the base of the chute with the four holes on the side of the Chipper/Shredder as shown in Photo 2-5. Secure the chute using the four screws (5/16"-18 x 5/8") and lockwashers (5/16") you received. Tighten this hardware very securely.

NEVER OPERATE EQUIPMENT UNLESS CHIPPER CHUTE IS ATTACHED.

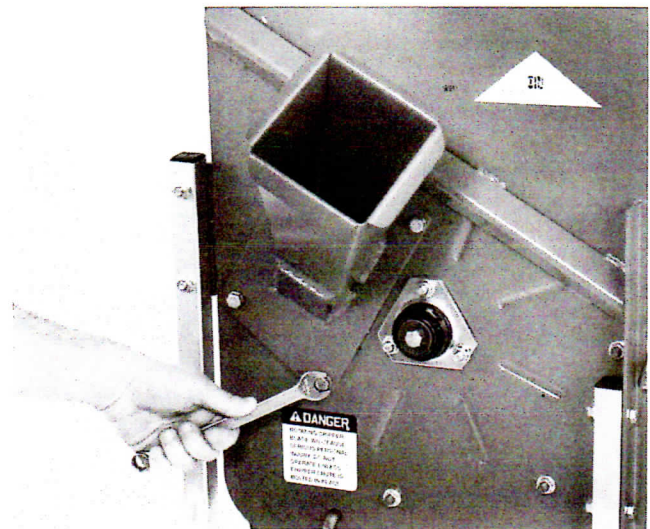

(Photo 2-5) Attach chipper chute to the side of your equipment. Use four screws (5/16"-18 x 5/8") and four lockwashers (5/16") to secure it. Tighten hardware firmly.

STEP 4: Belt Tension Check

The tension put on the drive belt (when your equipment's Clutch Lever is engaged) is adjusted at the Factory. **To be certain the tension is still correct before operation, please double-check the tension adjustment.** Here's how: **1)** Move the Clutch Lever **DOWN** to the "Engage" position as you see in Photo 2-6; **2)** The head of the Belt Tension Adjustment Bolt must be from 3/4"-to-13/16" away from the bushing it passes through; **3)** If an adjustment is needed, turn the bolt head counterclockwise to increase distance — clockwise to decrease the distance to the bushing. Once the bolt head has proper clearance from the bushing, move the Clutch Lever **UP** to the "Disengage" position. Note: this tension adjustment should be good for the life of the belt. See Section 5 if further belt tension information is needed.

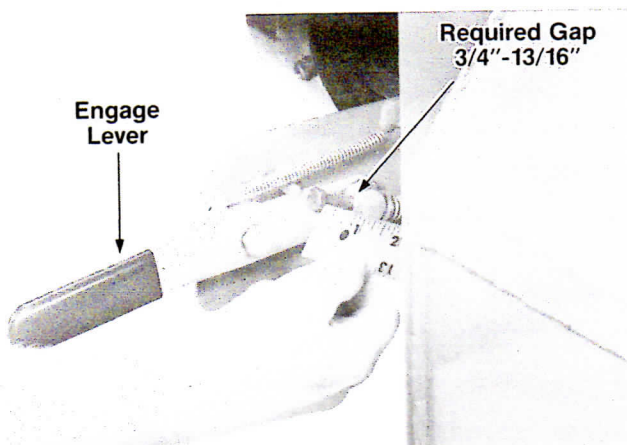

(Photo 2-6) Check belt tension adjustment. When Clutch Lever is **DOWN** in "Engage" position, head of Belt Tension Adjustment Bolt must be from 3/4"-to-13/16" away from bushing. Turn bolt in or out to get within this range.

STEP 5: Add Motor Oil To Engine

Your engine was shipped "dry." The proper type and amount of motor oil must be added to the engine crankcase before starting. *Use the instructions which follow that apply to your specific engine.* Note: the engine must be *level* for an accurate oil level reading. Move your equipment to a level surface (refer to Section 4 in this Manual for transporting instructions if you are not sure how to move your equipment properly).

How To Add Motor Oil To

5HP And 4HP Tecumseh Engines:

As recommended by the engine manufacturer, the motor oil specifications for 5HP and 4HP Tecumseh engines are — Use Clean High Quality Detergent Motor Oil with Engine Service Classification "SF" or "SG". *Summer (+32° F):* SAE30 weight oil (SAE10W30 is a substitute). *Winter (below 32° F):* SAE5W30 (SAE10W is a substitute). **NOTE: below 0° F ONLY, use SAE0W30. FILL 5HP CRANKCASE WITH APPROX. 19 OUNCES OF OIL. FILL 4HP CRANKCASE WITH 21 OUNCES OF OIL.**

Procedure (for 5HP Tecumseh engine):

1. Remove Oil Level Dipstick from Oil Fill Tube on top of engine (see Photo 2-7). Turn counterclockwise.
2. Insert clean funnel in Oil Fill Tube. Pour 19 ounces of motor oil into Oil Fill Tube. Note: **DO NOT OVERFILL WITH OIL.** Check level frequently while adding motor oil. Add oil until it reaches the "FULL" mark on the dipstick. To check the level, insert the dipstick, tighten it, and remove again.

Procedure (for 4HP Tecumseh engine):

1. Unscrew the Oil Fill Plug from the Fill Tube. It is located on the left hand side of the engine as you face the recoil start rope. See Photo 2-8. The plug should be turned counterclockwise.
2. Insert a clean funnel into the Fill Tube.
3. Slowly pour oil into the crankcase until it just begins to flow out of the Oil Fill Tube. Your engine should require about 21 ounces of oil.
4. Replace the Fill Plug securely.

How To Add Motor Oil To The 8HP Briggs Engines:

Motor oil specifications for this engine as recommended by the engine manufacturer are as follows: Use Clean High Quality Detergent Motor Oil classified for Service "SG", "SF", "SE", "SD", or "SC". *Summer (+40° F):* SAE30 weight oil (substitutes — SAE 10W30, SAE10W40 — these two substitutes may also be used from 0° F to 100° F). *Winter (below 20° F):* SAE5W20 or SAE5W30. **Nothing should be added to the recommended oil. FILL CRANKCASE WITH APPROX. 39 OZS. OF OIL.**

Procedure (for 8HP Briggs engines):

1. Remove the Oil Fill Plug from the Fill Tube (see Photo 2-9). Turn it counterclockwise. If necessary, use a screwdriver blade as a lever to loosen it.
2. Slowly pour about 39 ounces of motor oil through a clean funnel into the Fill Tube. Add until oil is right up to the top of the Fill Tube. **NOTE:** insufficient oil can cause engine damage!
3. Replace the Oil Fill Plug securely.

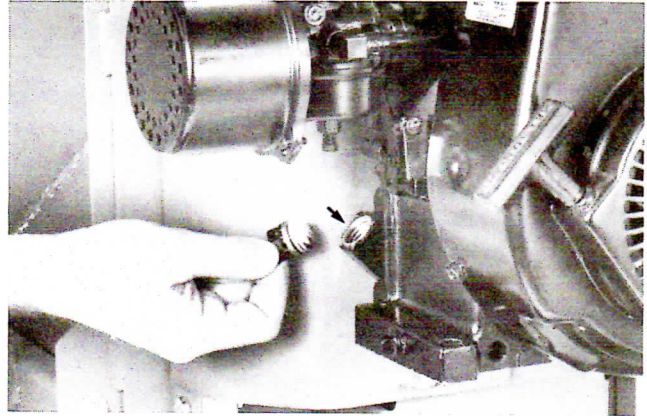

(Photo 2-8) On 4HP Tecumseh engines, turn and remove oil fill plug from left side of engine. Add oil to fill tube until it overflows (about 21 ounces). Replace the fill plug securely.



(Photo 2-7) On 5 HP Tecumseh engines, remove oil dipstick from oil fill tube, then add 19 ounces of motor oil using a clean funnel. Fill to "Full" mark on the dipstick. Do not overfill!

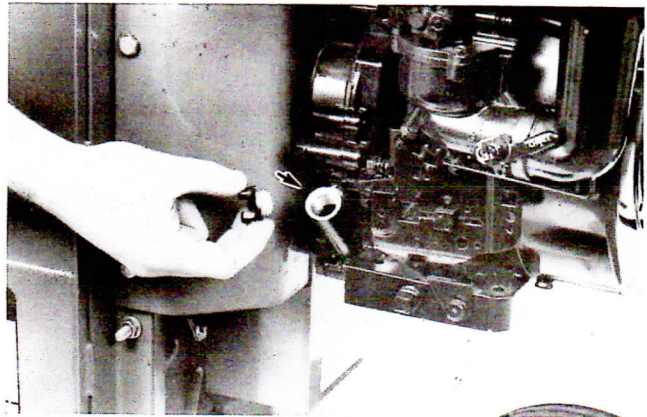

(Photo 2-9) On 8HP Briggs & Stratton engines, turn and remove oil fill plug. Add oil right up to the top of the oil fill tube. Approx. 39 ounces will be needed.

If you have a standard start chipper/shredder, it is now completely assembled.

If you have an electric start chipper/shredder, you will have to perform the following steps to assemble the electric starting system.

Assembly Instructions for the Electric Start System

IMPORTANT — The battery is shipped to you “dry” (empty), and *it can not be used* until it has been properly activated with electrolyte (battery-grade sulfuric acid) and given a proper start-up charge.

If you ordered an electric start Chipper/Shredder, it comes to you with most of the electrical system already assembled at the factory. Here are the final steps that are required for assembly of the electric start system.

The optional electric start system includes a 12-volt side-vented battery, a key switch ignition system, a solenoid, a starter motor (connected to the engine), and the cables and wires that connect the electrical system. A built-in recharging circuit on all the engines automatically recharges the battery during chipper/shredder operation.

Activating a battery with electrolyte is dangerous work (the acid can eat through clothing and burn skin), and we therefore strongly recommend that you take the battery to a local TROY-BILT Tiller Dealer or to a reliable service station, battery store or farm- or outdoor-power equipment center where a trained battery technician can complete the job safely. **PLEASE DO NOT ATTEMPT TO ACTIVATE THE BATTERY YOURSELF UNLESS YOU ARE FULLY EXPERIENCED IN BATTERY SERVICE WORK! SERIOUS PERSONAL INJURY COULD RESULT.**

Activating The Battery With Electrolyte And Charging The Battery

! DANGER

BATTERY ACID (ELECTROLYTE SOLUTION) CONTAINS SULFURIC ACID. CONTACT CAN CAUSE SEVERE BURNS.

AVOID CONTACT WITH SKIN, EYES AND CLOTHING. ALWAYS WEAR PROTECTIVE CLOTHING AND RUBBER GLOVES AND SHIELD EYES WITH SAFETY GOGGLES. NEUTRALIZE SPILLED ACID WITH BAKING SODA. KEEP CHILDREN AWAY.

ANTIDOTE: External — Flush with water. **Eyes** — flush with water for 15 minutes. Then get prompt medical attention.

ANTIDOTE: Internal — Drink large quantity of water or milk. Follow with milk of magnesia, beaten eggs, or vegetable oil. Get medical attention immediately.

! DANGER

BATTERIES PRODUCE EXPLOSIVE GASES WHICH CAN CAUSE SEVERE PERSONAL INJURY.

WHEN CHARGING OR USING BATTERY, DO SO IN A WELL-VENTILATED AREA. KEEP SPARKS, FLAME, SMOKERS' MATERIALS FAR AWAY. MAKE SURE BATTERY VENT AND VENT TUBE ARE NOT CLOGGED OR KINKED.

Activating The Battery

1. Place battery on a level surface and remove all filler caps. Leave the caps off during the filling and charging procedures. Batteries for 8HP and 5HP models are shown in Photos 2-10 and 2-11. There may be a short sealing tube over the battery vent — if so, remove and discard it.
2. Carefully fill each cell (there are six cells) with battery-grade electrolyte (1.265 Specific Gravity sulfuric acid) until it is level with the “UPPER” level line on the side of the battery case. By filling each cell to this height, the plates inside the battery will be completely covered as they should be. The temperature of the battery and the electrolyte should be between 60°-80° F for best results. **No water or other liquid should be added to the battery during this initial activation.**
3. After allowing the battery to stand for 30 minutes, check each cell and, if necessary, add more electrolyte solution so that the solution level reaches right up to the “UPPER” level line on the side of the battery case. **DO NOT overfill with electrolyte as this may cause electrolyte to flood over from the cells during battery charging.**

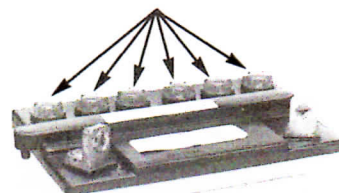

(Photo 2-10) The battery for 8HP Models is shown here. Remove all six filler caps in preparation for activation.

2

Easy Assembly

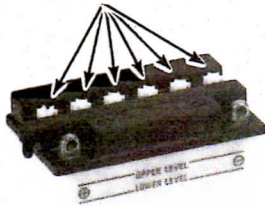

12N12A-4A-1
1-1000000000

(Photo 2-11) This is the battery we provide for the 5HP Model. To prepare it for activation, remove all six filler caps.

Charging The Battery

To obtain maximum starting capacity and longest life, your battery must be fully charged according to the instructions given below until all cells are gassing freely. When you check for gassing, wear safety goggles and use a flashlight to look into each cell while the battery is being charged. When gassing freely, the surface of the liquid electrolyte should be covered with tiny bubbles.

DANGER

BATTERIES PRODUCE EXPLOSIVE GASES WHICH CAN CAUSE SEVERE PERSONAL INJURY.

WHEN CHARGING OR USING BATTERY, DO SO IN A WELL-VENTILATED AREA. KEEP SPARKS, FLAME, SMOKERS' MATERIALS FAR AWAY. DO NOT LEAVE BATTERY UNATTENDED WHILE CHARGING. FOLLOW ALL CHARGING INSTRUCTIONS AND SAFETY RULES PROVIDED BY BATTERY AND RECHARGER EQUIPMENT MANUFACTURERS.

FOLLOW ONLY THIS CHARGING METHOD FOR THE BATTERY ON THE 5HP CHIPPER/SHREDDERS:

1. Charge this 12-volt battery at a rate of 1-to-2 amperes until all cells are gassing freely. Total charging time should not exceed 12 hours.
2. When the battery is fully charged, turn off the charger and disconnect the cables. Check electrolyte level in each cell, and if necessary add electrolyte until the level is up to the "UPPER" level line on the side of the battery case.
3. Replace the filler caps securely, but don't over-tighten them. Wash off any spilled electrolyte with a water and baking soda solution.

THERE ARE THREE POSSIBLE CHARGING METHODS FOR THE BATTERY ON THE 8HP CHIPPER/SHREDDERS:

Recommended Method:

Charge this 12-volt battery at a rate of 1-to-2 amperes until all cells are gassing freely. Total charging time should not exceed 24 hours.

First Alternative Method:

Charge the battery at a rate of 4-to-6 amperes until all cells are gassing freely. Total charging time should not exceed 8 hours.

Second Alternative Method:

Charge the battery at a rate of 6-to-12 amperes until all cells are gassing freely. Do not exceed 4 hours.

When the battery is fully charged, turn off the charger and disconnect the cables. Check electrolyte level in each cell. Add electrolyte to bring the level up to the "UPPER" level line on the side of the battery. Replace the filler caps and use baking soda and water to wash off any electrolyte on the battery.

DANGER

BATTERIES PRODUCE EXPLOSIVE GASES WHICH CAN CAUSE SEVERE PERSONAL INJURY.

DO NOT CHARGE YOUR BATTERY AT AN AMPERAGE HIGHER THAN SPECIFIED. EXCEEDING THE AMPERAGE RATE COULD GENERATE EXCESSIVE HEAT THAT WILL DAMAGE YOUR BATTERY.

Electrical Assembly Steps

Before installing the battery, make sure that the electrolyte level is at the "UPPER" line that is marked on the outside of the battery case.

DANGER

INSUFFICIENT FLUID IN BATTERY CELLS COULD LEAD TO A BATTERY EXPLOSION, RESULTING IN SEVERE PERSONAL INJURY.

BEFORE INSTALLING THE BATTERY, MAKE SURE THAT THE ELECTROLYTE LEVEL IS AT THE "UPPER" LINE. REFER TO PAGE 40 AT THE BACK OF THIS MANUAL FOR PROPER MAINTENANCE PROCEDURES.

2

Easy Assembly

STEP 1: Position The Battery On The Platform

DANGER

IMPROPER HANDLING OF BATTERY CAN RESULT IN ELECTRICAL BURNS, AN ELECTRIC SHOCK, OR AN EXPLOSION OF BATTERY GASES.

DO NOT TOUCH EITHER BATTERY POST SIMULTANEOUSLY WITH ANY OTHER SURROUNDING METAL PARTS WITH YOUR TOOLS, JEWELRY OR OTHER METAL OBJECTS TO AVOID INJURY.

A. On 8HP machines, first slip the clear plastic vent tube over the battery vent. Then place the battery on the platform, making sure that the positive (+) battery post faces the shredder wall. The battery vent should be about 1/2" away from the wall. On 5HP machines, as you position the battery, the positive (+) post must be on the right, the negative (-) post on your left. The correct position for the battery on the 8HP model is shown in Photo 2-12; the correct battery position on the 5HP model is shown in Photo 2-13.

CAUTION

BATTERIES ON THE 8HP MACHINES ARE POSITIONED DIFFERENTLY THAN THEY ARE ON 5HP MACHINES. PLEASE FOLLOW THE INSTRUCTIONS FOR YOUR PARTICULAR MACHINE. THE POSITIVE BATTERY POST MUST BE CONNECTED TO THE SOLENOID. FAILURE TO DO SO CAN RESULT IN DAMAGE TO BATTERY AND OTHER ELECTRICAL PARTS.

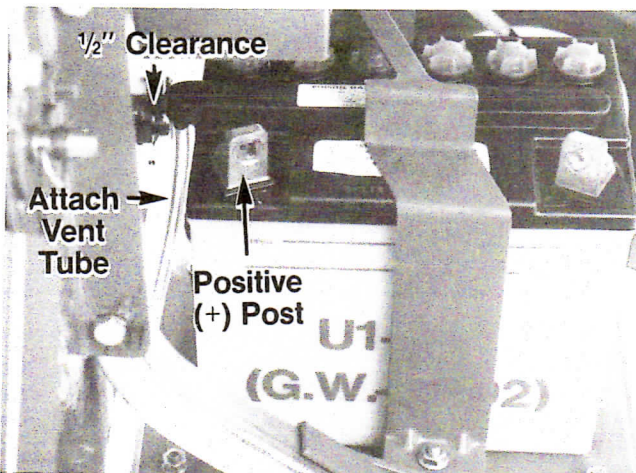

(Photo 2-12) The 8HP battery must be placed so the battery positive post faces the shredder wall. Slip the clear plastic vent tube on the battery vent. The holddown clamp and its hardware should be installed as shown.

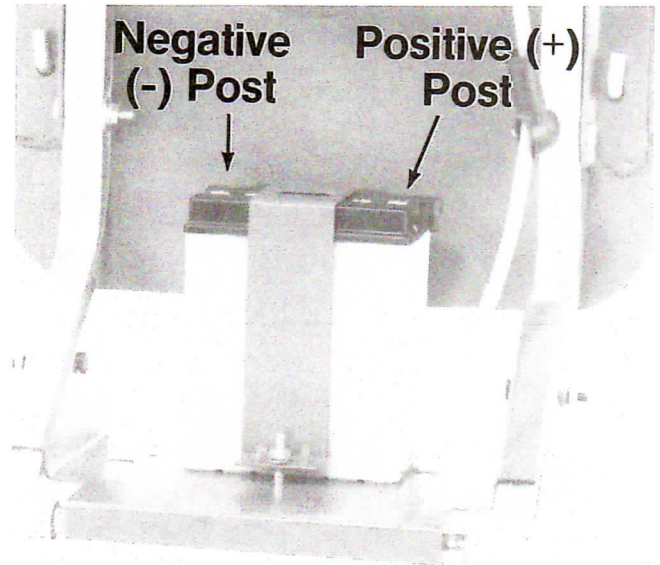

(Photo 2-13) The battery on the 5HP model must be positioned so the posts face as shown above. Place the holddown clamp over the battery as shown, then install only the front bolt to connect the clamp to the platform; the rear bolt will be installed later.

STEP 2: Install The Holddown Clamp

The holddown clamp should be mounted over the battery as shown in Photo 2-12 (8HP unit) and Photo 2-13 (5HP unit). On 8HP units, secure the clamp to the platform bolts with the two 1/4"-20 locknuts. On 5HP units, secure the clamp to the battery platform with the two 1/4"-20 x 1" long screws and 1/4"-20 locknuts you received. Install the screws from underneath the platform and mount the nuts on top. To prevent bending the clamp, do not overtighten the locknuts. Note: Owners of 5HP Chipper/Shredders should install the front bolt only at this time — once the battery cables are fully connected to your battery, then the rear holddown clamp bolt can be installed.

STEP 3: Connect Positive Cable To Battery

One end of the positive cable is already connected to the solenoid. Install the cable boot (from the electric start parts package) over the loose end of this cable. Then, connect the loose end of the cable to the positive (+) post on the battery using one of the small bolts and hex nuts you received. Refer to Photo 2-14 if you have an 8HP Chipper/Shredder; refer to Photo 2-15 if you have the 5HP Chipper/Shredder. NOTE: with the 5HP unit, turn the battery slightly as shown in the photo for more room to secure the hardware.

Once the cable is connected to the battery post, be sure to slide the black rubber boot completely over the cable-to-post connection. Photo 2-16 and Photo 2-17 show the boot as it should be positioned.

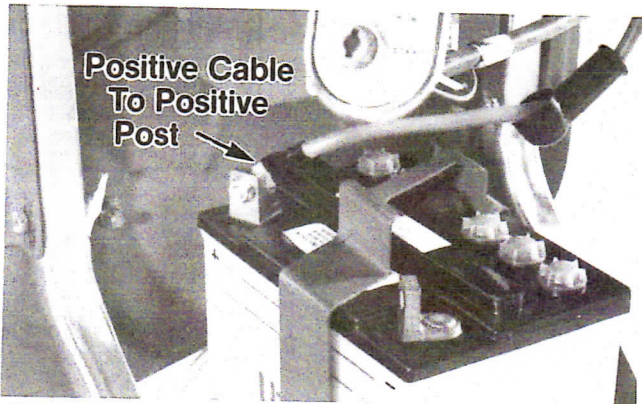

(Photo 2-14) On the 8HP electrical system, connect the positive (+) cable to the positive battery post as shown above. Use one of the small bolts and hex nuts to make the connection.

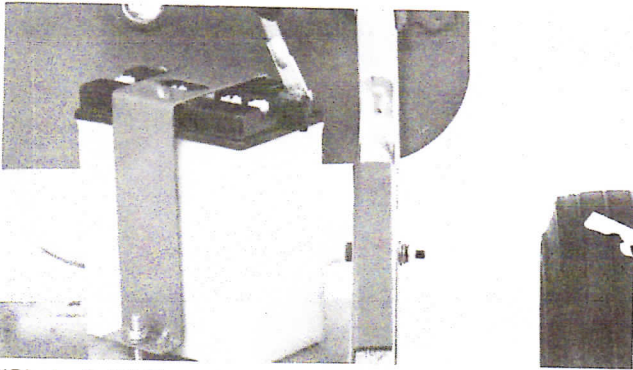

(Photo 2-15) Turn the 5HP battery slightly to one side to make bolt and nut installation easier. Be sure that hardware connecting the positive cable to the positive battery post is secure.

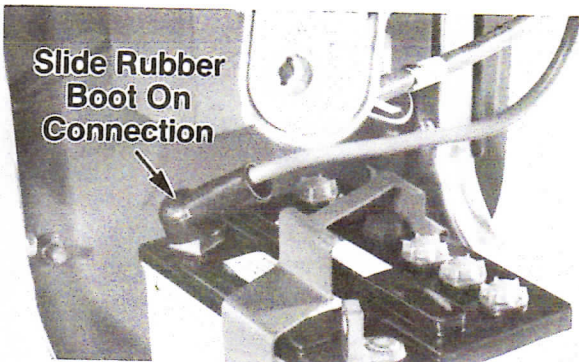

(Photo 2-16) Slide the rubber boot over the battery post and the end of the positive cable (8HP system shown).

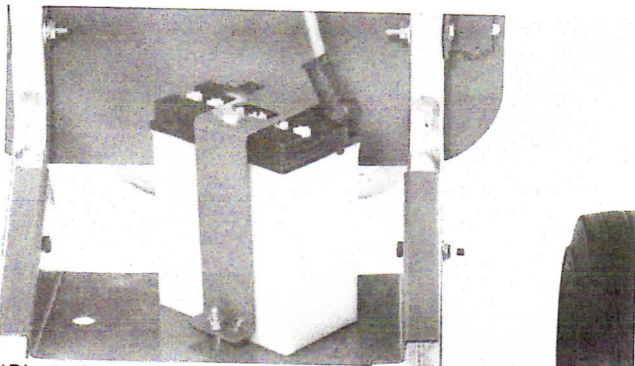

(Photo 2-17) As shown, the rubber boot must be slid completely over the cable-to-battery post connection (5HP system).

STEP 4: Connect Negative Cable To Battery

Remove the negative cable from the parts package. Connect the end of the cable with the small hole to the negative (-) post on the battery using the last small bolt and nut you received. See Photo 2-18 (8HP unit) and Photo 2-19 (5HP unit). Place the hardware just the way the positive cable hardware was connected to the battery.

DANGER

IMPROPER HANDLING OF BATTERY CAN RESULT IN ELECTRICAL BURNS, AN ELECTRIC SHOCK, OR AN EXPLOSION OF BATTERY GASES.

DO NOT TOUCH EITHER BATTERY POST SIMULTANEOUSLY WITH ANY OTHER SURROUNDING METAL PARTS WITH YOUR TOOLS, JEWELRY OR OTHER METAL OBJECTS TO AVOID INJURY.

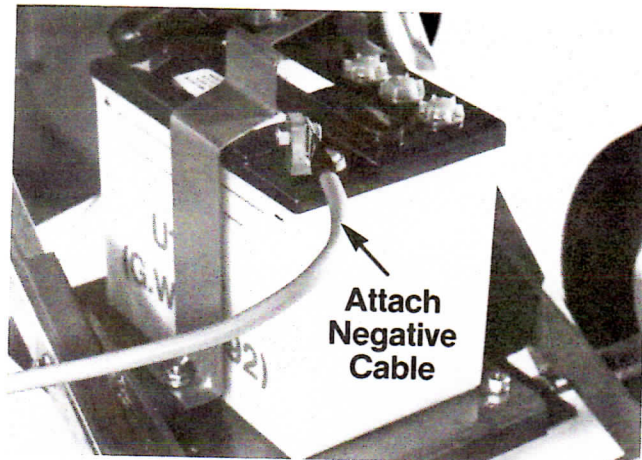

(Photo 2-18) Connect the negative cable from your hardware package to the negative battery post (8HP unit shown).

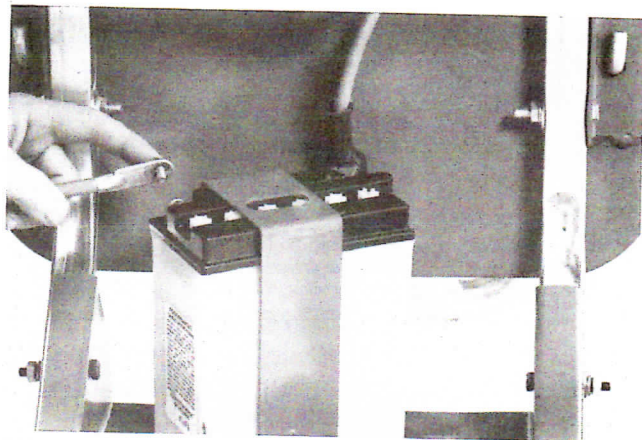

(Photo 2-19) On the 5HP unit, swing the battery to one side to make negative cable to negative battery post connection easiest. Once the cable is connected, straighten the battery, then connect the back of the hold-down clamp to the battery platform.

STEP 5: Connect Negative Cable To Ground Location; Then Secure The Vent Tube

Using an open end wrench, remove the whiz nut indicated in Photo 2-20. Position the loose end of the negative cable on the bolt, then replace the nut and tighten securely. This grounds the entire electrical system.

On all models, be sure the clear plastic vent tube is securely on the battery vent opening. See Photo 2-20. NOTE: on the 8HP battery, the vent tube should be lashed to the rear of the platform using the plastic wire tie sent to you. Be sure the clear plastic tube is not crimped or kinked in any way. Improper venting could lead to a battery explosion. On 5HP units, put the other end of the vent tube down through the drain hole in the battery platform. We suggest that you cut the vent tube (scissors or knife will do) so that it is about 2" above the ground.

DANGER

BATTERIES PRODUCE EXPLOSIVE GASES WHICH CAN CAUSE SEVERE PERSONAL INJURY.

THE BATTERY MUST ALWAYS BE PROPERLY VENTED TO SAFELY RELEASE GASES. MAKE SURE BATTERY VENT AND VENT TUBE ARE NOT CLOGGED OR KINKED.

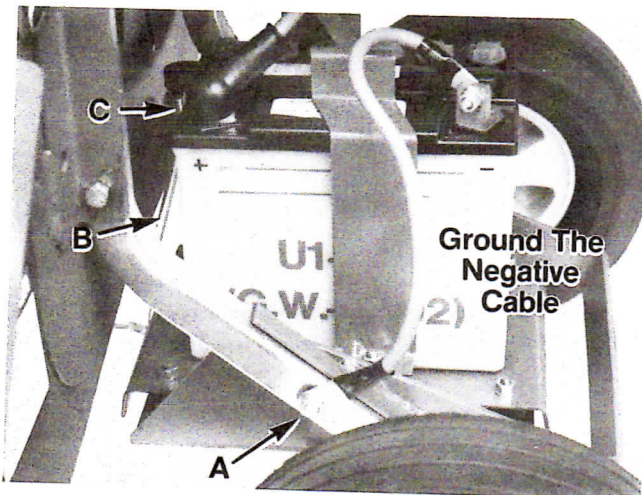

(Photo 2-20) Ground the electrical system by connecting the loose end of the negative cable to bolt "A". Just remove the nut, slide the cable end on the bolt, then replace the nut. Also slip the clear vent tube ("B") over the battery vent opening ("C"). The vent tube must not have any kinks.

STEP 6: Final Check Of All Electrical Connections

Now that the battery is activated, charged and installed, please make a visual check of all the wires in the wiring harness to be sure they're connected securely. Check these locations and refer to Photo 2-21.

- Be sure the plastic wire connector going to the keyswitch is securely attached.
- Be sure all wires attached to the solenoid are held firmly in place by their hardware.
- Check the starter cable connecting the starter motor to the solenoid — hardware should be tight.
- Also be sure the plastic connector on the recharging line is secure.

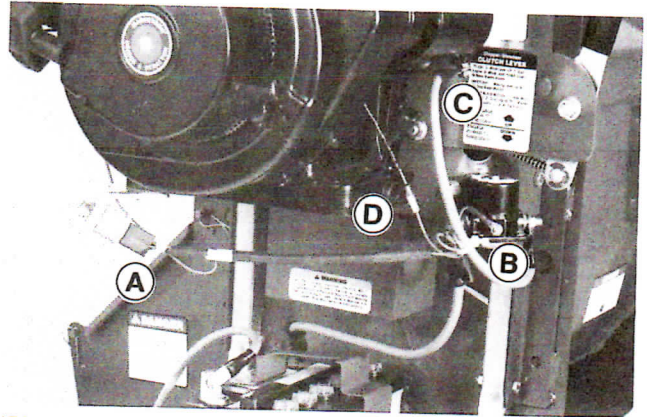

(Photo 2-21) On the wiring system, be sure the following connections are secure: wire connector to keyswitch ("A"); wires attached to solenoid ("B"); cable to starter motor ("C"); plastic connector on recharging line ("D"). 8HP system is shown above. NOTE: Your machine may be equipped with a different style keyswitch ("A") or solenoid ("B") than pictured above.

SECTION 3:

Features & Controls On The Chipper/Shredder And Engine

Before putting your new SUPER TOMAHAWK® Chipper/Shredder to work on the projects you've been planning, please read this Section completely to understand exactly how the equipment works and the location and function of all the features and controls. Basically, there are chipper/shredder features and there are engine features. This section groups them as such, and explains each in detail.

Chipper/Shredder Features & Controls

Please refer to Photo 3-1 to locate the following chipper/shredder features and controls:

1. Shredder Hopper (inlet)
2. Chipper Chute (inlet)
3. Chipper/Shredder Chamber
4. Discharge Tunnel
5. Clutch Lever

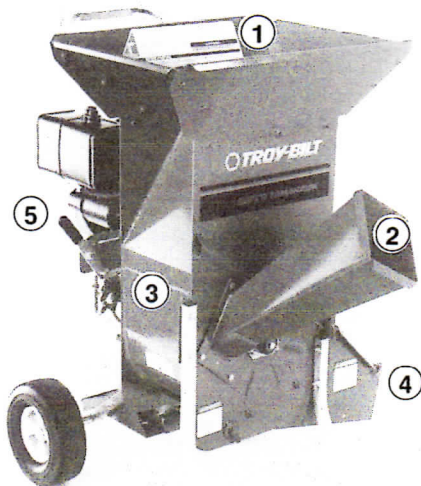

(Photo 3-1) Your equipment has the features/controls shown above, regardless of which engine option you chose.

1. Shredder Hopper (Inlet)

The Shredder Hopper (see Photo 3-2) is located at the top of the unit and is the opening into which all materials to be shredded should be fed. A rubber retainer flap is secured to the hopper. Material must be pushed past the retainer flap (use the Leaf Tamper or a stick) to enter the main chipper/shredder chamber where revolving steel cutters do the shredding (see Danger above). **The retainer flap is an important feature — it prevents kickback of materials! Do Not Use Your Equipment Unless The Rubber Retainer Flap Is Securely Fastened.** Most organic materials can be shredded. Section 4 provides a list of materials.

DANGER

CONTACT WITH INTERNAL ROTATING CUTTING BLADES WILL CAUSE SERIOUS PERSONAL INJURY. DO NOT PUT HANDS, FACE, FEET OR CLOTHING INTO THE SHREDDER HOPPER, CHIPPER CHUTE, DISCHARGE OPENING OR NEAR THE DISCHARGE AREA AT ANY TIME. MAINTENANCE AND SERVICE SHOULD ONLY BE PERFORMED AFTER THE ENGINE IS OFF, THE SPARK PLUG WIRE IS DISCONNECTED, AND ALL MOVING PARTS HAVE COME TO A COMPLETE STOP. USE ONLY A WOODEN STICK TO CLEAR JAMMED MATERIAL AFTER ALL MOVING PARTS HAVE STOPPED COMPLETELY.

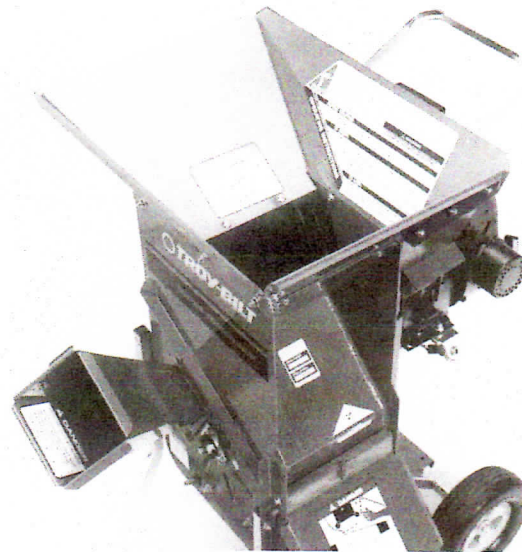

(Photo 3-2) The top-loading Shredder Hopper can be used to shred a variety of organic materials. The rubber retainer flap inside the hopper must always be securely fastened.

DANGER

SHREDDED PARTICLES CAN KICKBACK UP THROUGH THE SHREDDER HOPPER INLET UNLESS THE RUBBER RETAINER FLAP IS IN PLACE AND SECURELY FASTENED. PERSONAL INJURY CAN RESULT FROM FLYING PARTICLES.

BEFORE USING YOUR EQUIPMENT, BE SURE THE RETAINER FLAP IS SECURELY ATTACHED AND THAT YOU ARE WEARING PROTECTIVE SAFETY GOGGLES OR GLASSES.

2. Chipper Chute (Inlet)

This side-mounted Chipper Chute gives you a way to process into "chips" the larger, heavier materials that the Shredder wasn't designed to handle. The Chipper Chute is shown in a close-up in Photo 3-3. The chute is bolted to the side of your equipment with heavy-duty hardware. Branches fed into the chute are turned into "chips" by a revolving blade mounted on a flywheel. With 8HP and 5HP models, we recommend that branches and vines from 1" in diameter up to 3" in diameter be fed into the Chipper Chute. With 4HP models, use materials that are 3/4"-to-2" in diameter. It's a good idea to cut your materials into manageable lengths before feeding them into the Chipper. **Note: the Chipper Chute must be securely bolted to the side of your equipment before using the Chipper/Shredder!**

DANGER

CONTACT WITH INTERNAL ROTATING CUTTING BLADES WILL CAUSE SERIOUS PERSONAL INJURY. DO NOT PUT HANDS, FACE, FEET OR CLOTHING INTO THE SHREDDER HOPPER, CHIPPER CHUTE, DISCHARGE OPENING, OR NEAR THE DISCHARGE AREA AT ANY TIME. MAINTENANCE AND SERVICE SHOULD ONLY BE PERFORMED AFTER THE ENGINE IS OFF, THE SPARK PLUG WIRE IS DISCONNECTED, AND ALL MOVING PARTS HAVE COME TO A COMPLETE STOP. USE ONLY A WOODEN STICK TO CLEAR JAMMED MATERIAL AFTER ALL MOVING PARTS HAVE STOPPED COMPLETELY.

WARNING

DO NOT OPERATE YOUR EQUIPMENT UNLESS THE CHIPPER CHUTE IS PROPERLY BOLTED TO THE SIDE OF THE UNIT. SERIOUS PERSONAL INJURY CAN RESULT IF THE CHUTE IS NOT SECURELY ATTACHED.

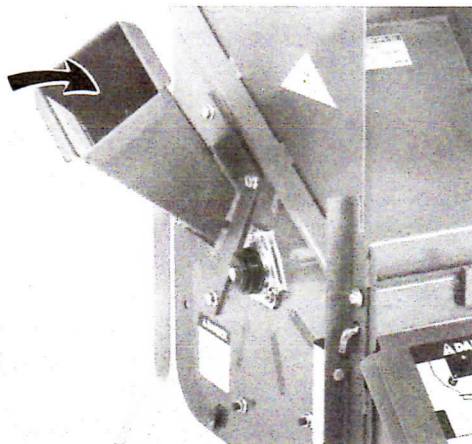

(4HP Model Shown)

(Photo 3-3) The Chipper Chute is for processing larger, heavier branches (1"-to-3" diameter in 8HP and 5HP machines; 3/4"-2" diameter in 4HP machines). It must be securely attached to your equipment at all times.

3. Chipper/Shredder Chamber

Inside the steel mainframe chamber of your equipment is a chipper flywheel/cylinder assembly that is bolted to the drive shaft. The round flywheel has a chipper blade attached to it. The cylinder assembly holds the shredder cutting blades ("flails") that do all the shredding. If you have an 8HP or 5HP model, your unit has 16 steel shredder blades; if you have a 4HP model, your machine has 12 steel shredder blades. Additional horsepower, plus the difference in blade count (and a 10" wide frame versus an 8" wide frame) is the reason the more powerful machines can handle thicker material (up to 1" in shredder; 1"-to-3" in chipper) than the 4HP unit (up to 3/4" in shredder; 3/4"-to-2" in chipper).

See Photo 3-4 for a view of the 5HP/8HP chipper flywheel/shredder cylinder assembly. When your equipment is running (engine started; Clutch Lever moved DOWN to "Engage" position), the chipper blade and the shredder blades revolve at the same time — making either chipping or shredding available to you.

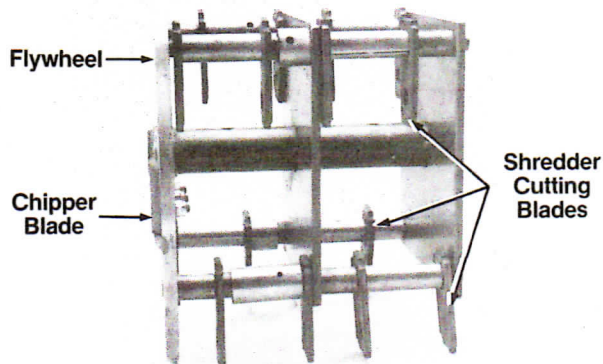

(Photo 3-4) Shown above is the chipper flywheel/shredder cylinder assembly used on 5HP and 8HP models (assembly is shown removed from main frame chamber for photo clarity only). The flywheel holds the chipper blade — feed branches up to 3" thick into the chipper chute (2" in 4HP model) and the chipper blade creates even-sized wood chips. Or feed material up to 1" (or 3/4" with 4HP models) thick into the shredder hopper and the cutting blades will process it.

DANGER

CONTACT WITH ROTATING CUTTING BLADES INSIDE THE CHIPPER/SHREDDER WILL CAUSE SERIOUS PERSONAL INJURY. DO NOT PUT HANDS, FACE OR CLOTHING INTO THE SHREDDER HOPPER, CHIPPER CHUTE, OR NEAR THE DISCHARGE AREA AT ANY TIME. MAINTENANCE AND SERVICE SHOULD ONLY BE PERFORMED AFTER THE ENGINE IS OFF, THE SPARK PLUG WIRE IS DISCONNECTED, AND ALL MOVING PARTS HAVE COME TO A COMPLETE STOP. THEN, USE ONLY A WOODEN STICK TO CLEAR JAMMED MATERIAL.

4. Discharge Tunnel & Discharge Screen

The discharge area on your equipment, as you stand facing the chipper chute, will be on the side to your right, near the bottom of the chipper/shredder. This is the location where all chipped and shredded materials exit once they've been processed. See Photo 3-5 for a close-up view of the discharge area.

Inside the discharge tunnel (refer to Photo 3-5) there is a steel discharge screen through which the processed materials must pass in order to exit from the discharge tunnel. The holes in the screen not only provide an exit from the internal chamber, but the **diameter of the holes in the screen determines how finely materials are shredded**. Your machine is fitted with a removable screen with 3/4" diameter holes — ideal for many of the tasks you'll be doing. However, should you need more finely shredded particles, or you wish to grind corn for feed, you may wish to order the optional screen with 3/8" holes; if more coarsely processed material is needed, order the optional screen with 1" diameter holes. Just call us and we'll be glad to assist you with screen selections.

! DANGER

CONTACT WITH INTERNAL ROTATING CUTTING BLADES WILL CAUSE SERIOUS PERSONAL INJURY. DO NOT PUT HANDS, FACE, FEET OR CLOTHING INTO THE SHREDDER HOPPER, CHIPPER CHUTE, DISCHARGE OPENING OR NEAR THE DISCHARGE AREA AT ANY TIME. MAINTENANCE AND SERVICE SHOULD ONLY BE PERFORMED AFTER THE ENGINE IS OFF, THE SPARK PLUG WIRE IS DISCONNECTED, AND ALL MOVING PARTS HAVE COME TO A COMPLETE STOP. USE ONLY A WOODEN STICK TO CLEAR JAMMED MATERIAL AFTER ALL MOVING PARTS HAVE STOPPED COMPLETELY.

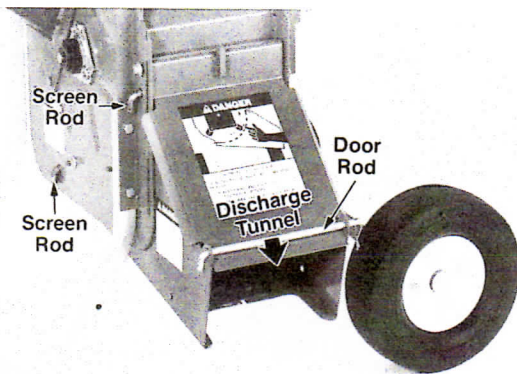

(Photo 3-5) Chipped and shredded materials are discharged from the discharge tunnel. To avoid personal injury, stay away from this area during operation. A removable screen inside the tunnel is interchangeable with other optional screens to vary the size of discharged material.

Reasons To Remove The Discharge Screen:

- **The screen may need cleaning.** Holes in the screen may be clogged, thereby preventing materials from being discharged.
- **You may want to process wet or green materials like damp or matted leaves, spoiled or leftover vegetables, manure and the like.** This is best accomplished by removing the screen and running your equipment without a screen in place. In this way, clogging will be kept to a minimum.
- **You may wish to alter the size of discharged material.** Removing the standard screen with 3/4" holes and installing one of the optional screens accomplishes this.

How To Remove The Discharge Screen:

! DANGER

ROTATING CUTTING BLADES INSIDE THE DISCHARGE OPENING WILL CAUSE SERIOUS PERSONAL INJURY.

BEFORE OPENING SERVICE DOOR TO REMOVE DISCHARGE SCREEN, BE CERTAIN THE ENGINE IS OFF, ALL MOVING PARTS HAVE STOPPED COMPLETELY, AND THE SPARK PLUG WIRE IS DISCONNECTED.

1. Be sure the engine is off, all moving parts have stopped completely, and the spark plug wire is disconnected. It's now OK to start work.
2. You must open the Service Door to gain access to the discharge screen. To open the door, first remove the Hairpin from the steel rod shown in Photo 3-6, then slide the rod out from the two tabs. Once out, the Service Door can be lifted and the screen inspected. If the screen must be removed, proceed as follows.

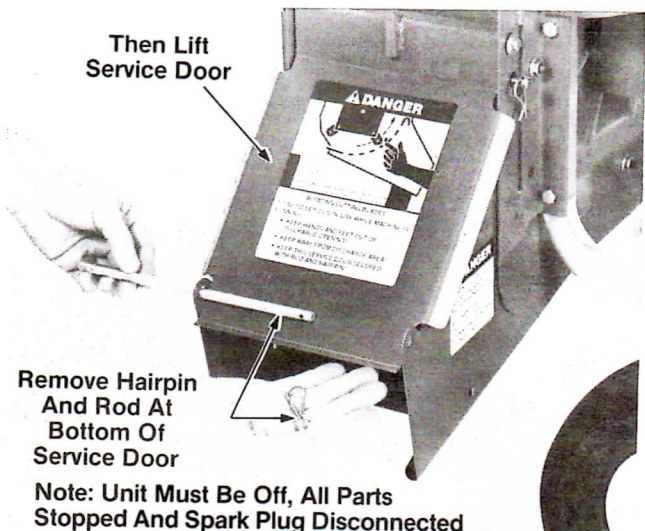

(Photo 3-6) Remove the hairpin and the rod securing the front of the Service Door. Lift the door up to inspect the discharge screen.

3. Two other rods and hairpins secure the screen to the mainframe. Remove the rod (and hairpin) at the far end (furthest from service door) of the screen (see Photo 3-7), then the rod and hairpin at the near end of the discharge screen (see Photo 3-7). Note: if you have an electric start model, the hairpin furthest from you can be most easily removed by walking around to the other side of the machine. (See photo inside Photo 3-7).

4. Once the rods are out, lift up the Service Door and slide the screen out from the mainframe by using the built-in handle (refer to Photo 3-8). You can now clean the shredder thoroughly, or clean the interior of the shredder chamber with a stick if necessary, or install one of the other optional screens if desired.

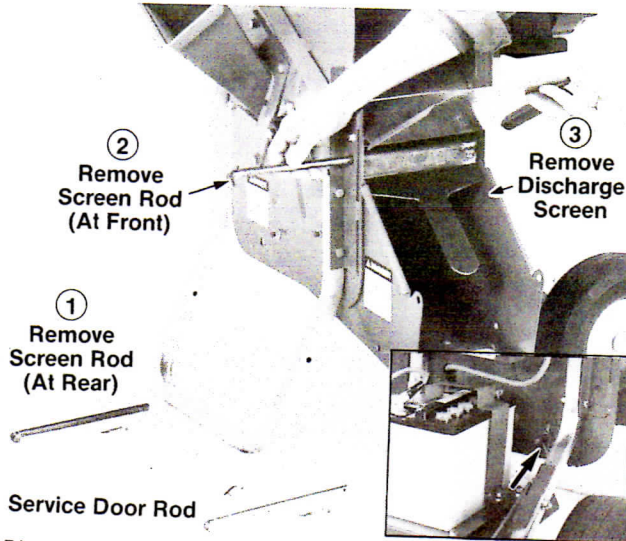

(Photo 3-7) Slide out the rear and front rods in order to remove the Discharge Screen. Hold the Service Door up and support the screen while you remove the front rod last. The screen is then free. Electric Start owners — the easiest way to remove the rear rod and hairpin on your machine is to walk around to the other side. See the inset Photo above.

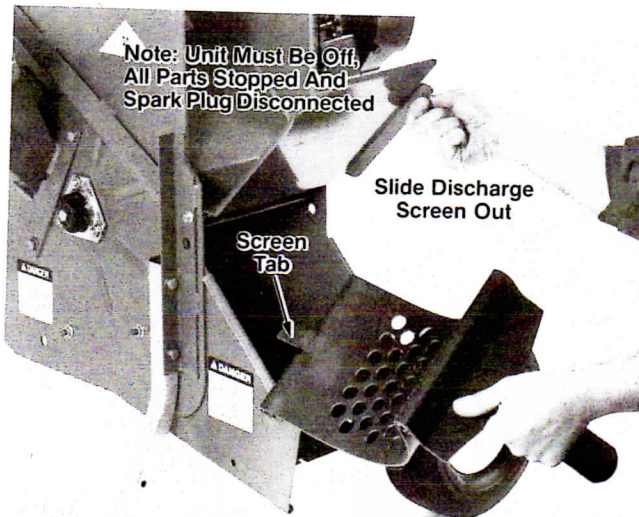

(Photo 3-8) Carefully slide the screen out. Note that there is a positioning tab at the far end of the screen. When installing the screen, the tab must go into a slot on the other side of the mainframe. Go to the other side of your machine and you'll see the tab protruding through the slot when the Discharge Screen is properly positioned. Remember to put all three rods back in and to secure them with the hairpins.

How To Install The Discharge Screen:

Note: if you've been shredding wet or green material with the screen out, you'll want to clean out the tunnel and perhaps even the inner chamber with a stick first, before installing the discharge screen. Never clean tunnel or chamber while unit is running.

1. With the service door up, position the screen so the tab at the end of the screen goes into the slot at the back of the mainframe.
2. Install one rod and a hairpin to secure the **front end** of the screen.
3. Install one rod and its hairpin at the **rear end** of the discharge screen, using the tab to assist you in aligning the screen hole and the rod.
4. Lock the service door closed with the last rod and hairpin.

IMPORTANT — The hairpins supplied with your machine are the only style hairpins that should be used.

5. Clutch Lever

The Clutch Lever can be moved to either of two positions: UP or DOWN. It should be UP only while the engine is being started, and DOWN at all other times. Once the engine starts, slowly move the lever all the way DOWN to "ENGAGED" — this tightens the belt tension and lets power from the engine turn the drive-shaft. The chipper blade and shredder cutting blades will build up speed to 3600 RPM.

IMPORTANT — Moving the Clutch Lever UP to "DIS-ENGAGED" will NOT STOP blade motion! The only way to stop blade motion is to shut the engine off while the Clutch Lever is DOWN. The blades will slow down very gradually before stopping because they were rotating at such high speed. Refer to Photos 3-9 and 3-10 for the "UP" and "DOWN" Clutch Lever positions. See full operating instructions on the Clutch Lever in Section 4.

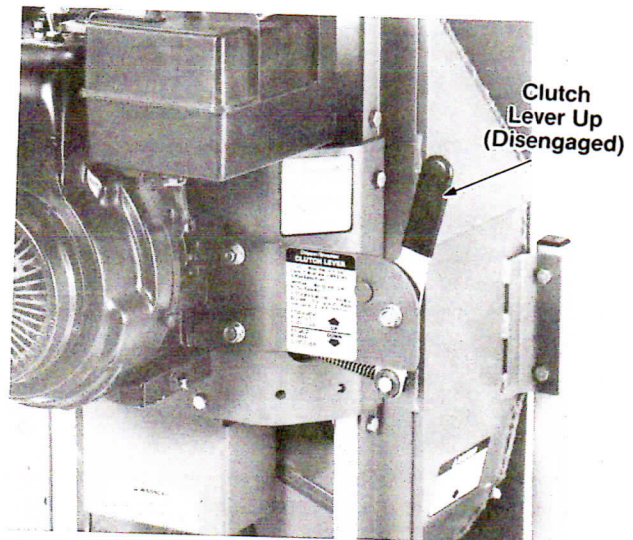

(Photo 3-9) The Clutch Lever should be UP as shown only when starting the engine. Move it DOWN slowly to make the chipper and shredder cutting blades rotate. Keep the Clutch Lever DOWN at all times (except when starting engine).

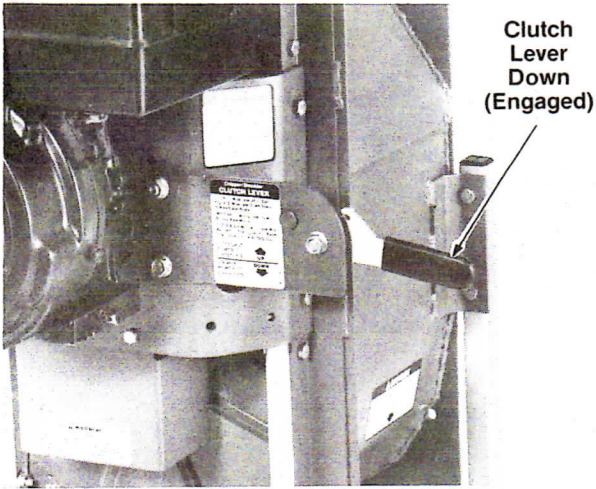

(Photo 3-10) Moving the Clutch Lever DOWN to the "ENGAGE" position after the engine is started allows engine power to be transferred through the drive belt to the chipper/shredder cylinder assembly.

⚠ DANGER

ROTATING CUTTING BLADES ARE REVOLVING AT HIGH SPEED WHEN THE ENGINE IS RUNNING AND THE CLUTCH LEVER IS DOWN (ENGAGED). BLADES SLOW DOWN GRADUALLY AFTER ENGINE IS SHUT OFF. TO AVOID SERIOUS PERSONAL INJURY DO NOT PUT HANDS, FACE, FEET OR CLOTHING NEAR OR INTO SHREDDER HOPPER, CHIPPER CHUTE, DISCHARGE OPENING OR NEAR THE DISCHARGE AREA.

Engine Features & Controls

1. Carburetor Choke Control
2. "On-Off" or "Run-Stop" Switch (5HP and 4HP Tecumseh engines); "On-Off" Switch (8HP Briggs & Stratton engine)
3. Manual Start and Optional Electric Start
4. Fuel Tank

1. Carburetor Choke Control

The 5HP Tecumseh, 4HP Tecumseh, and 8HP Briggs & Stratton engines have a Choke Control Lever located on the carburetor. This lever lets you regulate the air-fuel mixture to make starting a cold engine easier. Use the FULL CHOKE position when starting a cold engine; switch to PARTIAL CHOKE (Half Choke) for a few seconds once the engine is started; use the NO CHOKE position when warming up the engine and during general operation. Important: if engine falters when the choke lever is in the NO CHOKE position, switch back to PARTIAL CHOKE temporarily. ALWAYS HAVE THE CHOKE LEVER IN THE NO CHOKE POSITION DURING GENERAL OPERATION. Harmful deposits will build up inside the engine if you don't do this.

Tecumseh 5HP Choke Control Lever: see Photo 3-11 for its location on the engine. This lever has an "arrow-head" shape — the point of the arrow indicates the direction in which the lever must swing for the FULL CHOKE position.

Tecumseh 4HP Choke Control Lever: refer to Photo 3-12. Like the 5HP Tecumseh engine, this engine has a choke lever in the form of an "arrowhead". Swing the lever in the direction the arrow is pointing to activate the choke mechanism.

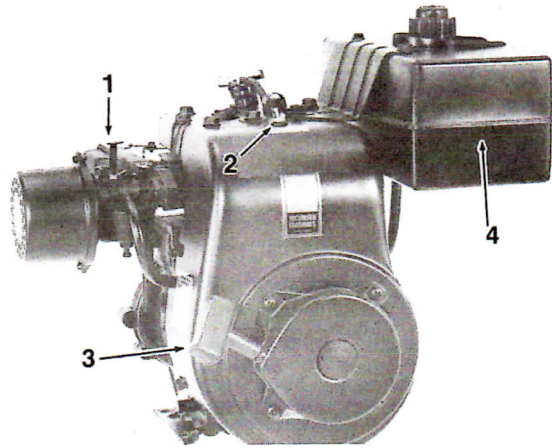

(Photo 3-11) Controls on the 5HP Tecumseh engine: Choke Lever ("1"); Rotary-style On-Off or toggle-style Run-Stop Switch ("2"); Recoil Starter ("3"); Fuel Tank ("4"). (Electric start Tecumsehs have a keyswitch instead of a top-mounted On-Off or Run-Stop Switch).

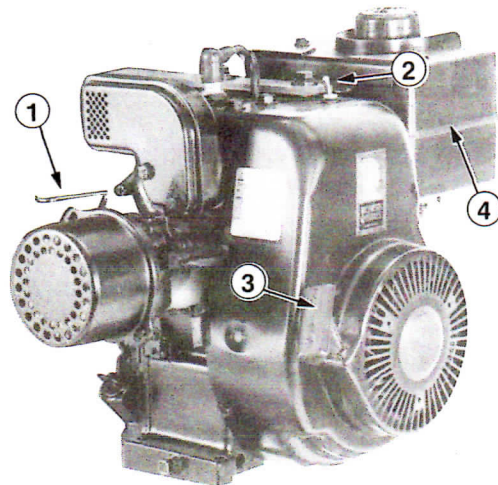

(Photo 3-12) Here are the major controls on the 4HP Tecumseh engine: Choke Lever ("1"); Either a rotary-style On-Off or toggle-style Run-Stop Switch ("2"); Recoil Starter ("3"); Fuel Tank ("4").

SECTION 4:

Operating Instructions

DANGER

CONTACT WITH ROTATING CUTTING BLADES INSIDE DISCHARGE OPENING WILL CAUSE SERIOUS PERSONAL INJURY.

READ THE COMPLETE OWNER/OPERATOR MANUAL, INCLUDING THESE OPERATING INSTRUCTIONS, BEFORE USING YOUR EQUIPMENT.

This section provides you with detailed information on the use of your Chipper/Shredder, lots of helpful tips to make jobs go faster and smoother, and an important Checklist of Pre-Starting Steps and Engine Starting Steps that you should always use. **Please read the information in this section before starting engine.**

IMPORTANT — Do not allow processed material to build up beside or beneath the machine to the point where it contacts the Discharge Tunnel. If material can not freely exit via the Discharge Tunnel into the discharge area, it will continue to circulate within the processing chamber leading to clogs and the possibility of having some of the material being “blown” back up through the feed hopper.

To remove discharged material from the discharge area, use a long-handled shovel or stick.

Use The Shredder For Most Materials; Use The Chipper For the Biggest, Toughest Jobs

To get the greatest benefits from your equipment, it's important to know which materials are best fed into the Shredder hopper and which ones are best fed into the Chipper chute. **Under no circumstances should you feed metal, glass, bottles, plastic, cans, rocks or other such foreign objects into your equipment. Please see examples of appropriate materials for chipping and shredding listed below.**

Materials Best Suited For Shredding:

Due to the wide variety of materials that can be shredded, and their very different physical characteristics, **we suggest that you feed limited quantities of any material to begin with.** Bulk and lengths can be increased if you find the material is being processed without any difficulty. Your judgement is important — *be sure not to overload the Shredder.* Overloading will cause engine speed to decrease significantly, making the engine labor and cause poor performance.

- Twigs and branches — up to 1" in diameter in the Shredder hopper (3/4" in 4HP Model). Several small

branches can be fed into the Shredder hopper at once providing their combined diameter is less than 1". Longer branches (more than 2-to-3 feet) should be cut to make them more manageable. Green materials should be allowed to dry, or processed in small batches with dry materials, to avoid winding up and binding the cylinder. Wet materials will clog up easily, so remove the discharge screen **before** processing them.

- Leaves, grass clippings, and all other light, loose materials. These process most easily.
- Organic waste materials and organic garbage (be sure to first remove all metal, bottles, cans, rocks, and plastic).
- Sections of vines less than 1" (3/4" if you have a 4HP) in diameter. Long vines should be cut to manageable lengths — 2-to-3 feet.
- Wood chips processed by the Chipper if even finer particles are required.
- All paper trash.
- Partially finished compost.
- Stalks and most brush material.
- A mixture of any of the materials listed above.

Materials Best Suited For Chipping:

- Thicker branches — from 1"-to-3" in diameter (3/4"-to-2" with 4HP Models), depending upon hardness of wood. Extremely hard knots will not process very well. Short, thick branches (up to 3" in diameter) that are left over after an original longer branch was fed through the chipper may also be chipped — move these shorter stubs through the chipper with the next longer branch you'll be chipping.
- Tough 1"-to-3" diameter stalks. We recommend not chipping vines smaller than 1" in diameter. Cut them to manageable lengths — no more than five or six feet long — before chipping them.

DANGER

CONTACT WITH ROTATING CUTTING BLADES WILL CAUSE SERIOUS PERSONAL INJURY. THE CHIPPER AND SHREDDER BLADES ROTATE AT EXTREMELY HIGH SPEED.

NEVER PUT YOUR HANDS OR ANY OTHER PART OF YOUR BODY INTO THE CHIPPER CHUTE, SHREDDER HOPPER INLET, OR DISCHARGE OPENING WHEN MACHINE IS RUNNING. BEFORE SERVICING OR UNCLOGGING JAMMED MATERIAL, SHUT OFF THE ENGINE, LET ALL MOVING PARTS COME TO A COMPLETE STOP, AND DISCONNECT THE SPARK PLUG WIRE. ROTATING BLADES SLOW DOWN GRADUALLY AFTER THE ENGINE IS OFF — LET THEM COME TO A COMPLETE STOP BEFORE SERVICING.

4

Operating Instructions

Transporting The Chipper/Shredder

When you move your equipment, please follow the instructions below. Remember — the SUPER TOMA-HAWK® Chipper/Shredder weighs over 200 pounds. **This weight must be properly balanced over the wheel axle and carefully rolled in order to move the equipment safely and easily.** Here's how:

- First shut the engine OFF. Keep the Clutch Lever in "ENGAGED" position (DOWN) until all moving parts stop completely. The Chipper and Shredder blades will slow down gradually. Allow the moving blades to come to a complete stop before proceeding. After they have stopped, move the Clutch Lever to "DISENGAGE" position (UP). Then disconnect the spark plug wire.
- Space both hands evenly and firmly on the handlebar. A good grip is very important.
- Place one foot on the wheel axle (on electric start models, put your foot on the battery bracket), halfway between the ends of the axle. Your other foot should be firmly planted.
- While steadying the equipment with the foot that's on the axle, pull the handlebar toward you (Photo 4-1).
- As the equipment tilts back toward you, stop pulling when you find the balance point (center of gravity) and hold the equipment there. Take your foot off the axle.
- Slowly pull or push the Chipper/Shredder to the work area. Be sure the path is clear of obstacles and that you keep a firm grip on the handlebar. On smooth, level ground, it's easier to push the unit. Pulling is better when the wheels have to go over ruts or obstacles.
- At your destination, make a complete stop. Then put your foot back on the wheel axle (or battery bracket) to steady the wheels and lower the handlebar slowly until the front stand touches the ground. Remember — your equipment should only be used on an earthen, level



(Photo 4-1) To move your Chipper/Shredder, plant one foot on the axle, tilt equipment back with both hands until "balance point" is reached, then push or pull your equipment to a work area. Engine must be OFF.

surface...not on hard driveways, patios or gravel where discharged materials can bounce back up and strike you or others.

DANGER

THE ROTATING SHREDDER CUTTING BLADES INSIDE THE DISCHARGE OPENING CUT 1/4" FROM THE DISCHARGE SCREEN. CONTACT WITH ROTATING CUTTING BLADES WILL RESULT IN SERIOUS PERSONAL INJURY. KEEP HANDS AND FEET OUT OF DISCHARGE OPENING AND AWAY FROM DISCHARGE AREA WHEN MACHINE IS RUNNING, AND WHILE BLADES ARE COASTING TO A STOP.

IN ORDER TO REMOVE CHIPPED OR SHREDDED MATERIAL FROM THE DISCHARGE AREA, USE A LONG-HANDLED SHOVEL OR LONG STICK — NEVER USE YOUR HANDS OR FEET! IF MATERIAL SHOULD EVER CLOG THE CHAMBER, DISCHARGE TUNNEL, OR DISCHARGE OPENING, SHUT OFF THE ENGINE, LET ALL MOVING PARTS STOP COMPLETELY, AND DISCONNECT THE SPARK PLUG WIRE. USE A STICK TO CLEAR CLOGGED MATERIAL.

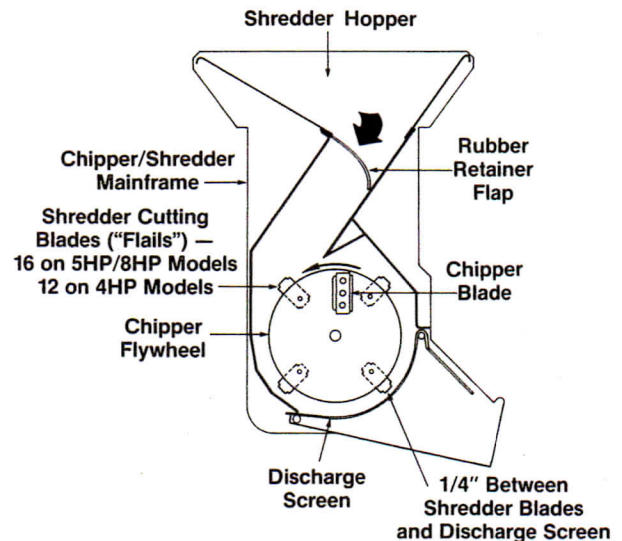

Shredder blades pass within 1/4" of discharge screen — KEEP HANDS AND FEET AWAY from Discharge Area at all times to avoid serious personal injury!

Pre-Starting Steps

1. Engine must be OFF. Disconnect the spark plug wire temporarily. Move your equipment to the work area. Select a level, earthen surface...never a hard surface (like concrete, macadam, brick, patio block, gravel or rocks) which can cause discharged materials to bounce upward.
2. Check the engine for correct oil level.
3. Add gasoline to the fuel tank, if needed. Follow safety requirements in Section 1.

4. Be sure all bystanders are at least 25 feet away from the area of operation.
5. Put on your safety goggles, hearing protectors, and sturdy work gloves.
6. Visually check the Chipper Chute and the Shredder Hopper to see that they're empty.
7. Check the Discharge Screen to be sure it's correctly and securely installed and the screen holes are not clogged. If clogged, clean them with a stick. Be sure all hardware is securely fastened. The Service Door must be closed and secured with a rod and hairpin.
8. Reconnect the spark plug wire. You are now ready to start the engine.

Engine Starting & Stopping Steps

DANGER

ROTATING CUTTING BLADES INSIDE THE CHIPPER/SHREDDER CHAMBER ARE IN OPERATION ONCE THE ENGINE IS STARTED AND THE CLUTCH LEVER IS MOVED TO THE "ENGAGE" POSITION. CONTACT WITH CUTTING BLADES WILL CAUSE SEVERE INJURY. KEEP HANDS, FEET AND CLOTHING AWAY FROM CHUTE AND HOPPER INLETS AND DISCHARGE AREA AT ALL TIMES.

How To Start

1. Move the Carburetor Choke Control Lever to FULL CHOKE Position (see Photo 3-11, 3-12, or 3-13 in Section 3) if the engine is being started "cold".
2. If you have the 5HP or 4HP Tecumseh Manual Start engine, move its On-Off rotary-style switch to "On" or the Run-Stop toggle-style switch to "Run" (you may have either type switch). Move the 8HP Briggs & Stratton On-Off Switch to "On" (see Figures 3-14 or 3-15). Disregard if you have an Electric Start engine.
3. Put Clutch Lever in UP position (Photo 3-9).
4. Grip the Starter rope handle securely (Photo 3-16). Pull the rope out slowly until you feel resistance. Then quickly pull the rope firmly all the way out to start the engine. Several attempts may be needed. With Electric Start engines, turn Keyswitch to "START". Once the engine starts, let it warm for a few seconds with the Choke in "Full" position, for a few more seconds with the Choke in "Partial" position—finally move the choke to "No Choke".
5. To transfer engine power to the Chipper/Shredder cutting blades, SLOWLY swing the Clutch Lever down. **Doing this too quickly will cause the engine to stall.** The cylinder assembly holding the shredder flail cutter blades and the chipper disc holding the

chipper blade will start to revolve. In a few seconds the blades will begin to build up to full speed — 3600RPM! Once you hear the cylinder assembly reach full operating speed, only then move the Clutch Lever all the way down. Learning how to engage the Clutch Lever properly will take a few tries, much like learning a manual transmission automobile. Your equipment is now ready to use.

DANGER

ROTATING CUTTING BLADES SLOW DOWN GRADUALLY AFTER ENGINE IS SHUT OFF. BLADES NORMALLY REQUIRE 30-TO-45 SECONDS TO STOP. ROTATING BLADES CAN CAUSE SERIOUS PERSONAL INJURY.

KEEP HANDS, FEET, FACE AND CLOTHING OUT OF THE CHIPPER CHUTE INLET AND SHREDDER HOPPER INLET, AND AWAY FROM THE DISCHARGE OPENING WHEN MACHINE IS RUNNING.

How To Stop:

1. **STOP** — On a manual start Tecumseh engine, move the "On-Off" Switch to "Off" or the "Run-Stop" Switch to the "STOP" position. On the manual start Briggs engine, turn the "On-Off" Switch to the "OFF" position. On Electric start versions, turn the key "OFF". Leave the Clutch Lever DOWN; this utilizes engine compression as a partial brake to reduce stopping time. The cylinder normally requires 30-to-45 seconds to stop.
2. **LISTEN** — Remove hearing protection. There is a definite audible tone that changes as the cylinder slows. Removal of hearing protection aids you in detecting this changing tone.
3. **LOOK** — The bearing on the chipper side of your machine has a white line on it. When this white line is stationary, the cylinder assembly is stopped.

IMPORTANT — If the drive belt should ever break or slip off a pulley, or the Clutch Lever is accidentally moved UP, the stopping time required for the cylinder assembly will increase to 90-to-120 seconds or even longer after the engine is shut off. Listen and Watch to be sure cylinder assembly has stopped completely.

In the unlikely event of a malfunction in the keyswitch or the engine shutoff switch, the shredder may be stopped by moving the engine "Choke" lever to the "Full Choke" position until cylinder assembly stops. Do not continue to stop unit in this manner since it could lead to engine damage. Determine problem and replace necessary parts.

4

Operating Instructions

How To Use The Chipper

After the engine is started and the Clutch Lever is moved to the "DOWN" position, the chipper blade will build up to 3600 revolutions per minute. The chipper is then ready to use. Be sure to wear safety goggles, gloves and hearing protection.

Position yourself on the right or left side of the Chipper Feed Chute (see Photo 4-2). The chipper will process branches from 1"-to-3" (4HP Model to 2") in diameter. To reduce branches to small chips, simply grip one end of a branch firmly with both hands and feed the other end of the branch into the chipper chute. Don't feed material with your arms pointing toward the chipper chute opening. Keep your arms perpendicular to the branch or material you are chipping. **Keep the branch away from your body to avoid any bounceback, and don't overreach.** Hold the branch firmly so you can control the rate of feed at all times (see Photos 4-3, 4-4).

All branches should be *evenly rotated* when fed into the chipper. This will help to prevent the bark from turning into long strips or strings that can get tangled around the internal cylinder shaft.

Feed the branch into the chipper chute until just a few inches stick out from the chute. **NEVER put your hands into the chipper chute. SHORT stubs of branches may be pushed through the chipper with the next branch.** Pay close attention to engine speed. **If the engine slows down, reduce feed pressure and let the engine build up to full speed again before continuing.** Avoid overloading the chipper.

DANGER

CONTACT WITH ROTATING CUTTING BLADES WILL CAUSE SERIOUS PERSONAL INJURY. BLADES ROTATE WHEN ENGINE IS ON AND CLUTCH LEVER IS ENGAGED, AND SLOW GRADUALLY AFTER ENGINE IS SHUT OFF.

KEEP HANDS, FEET AND CLOTHING AWAY FROM THE CHIPPER AND SHREDDER FEED INLETS AND THE DISCHARGE OPENING WHEN MACHINE IS RUNNING.

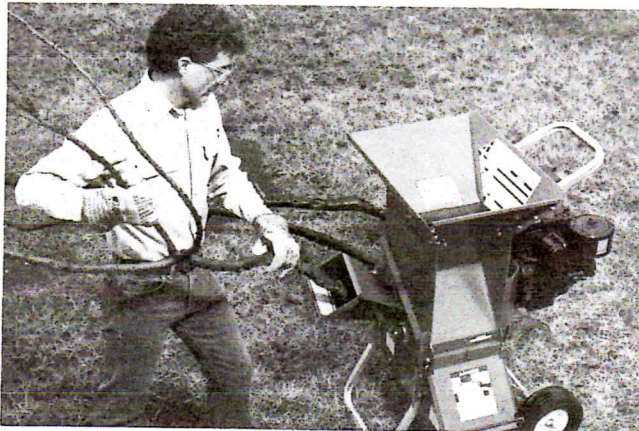

(Photo 4-2) Feed material into chipper at proper angle, and rotate branch. Do not overload the chipper.



(Photo 4-3) Hold branches firmly; feed in smoothly.

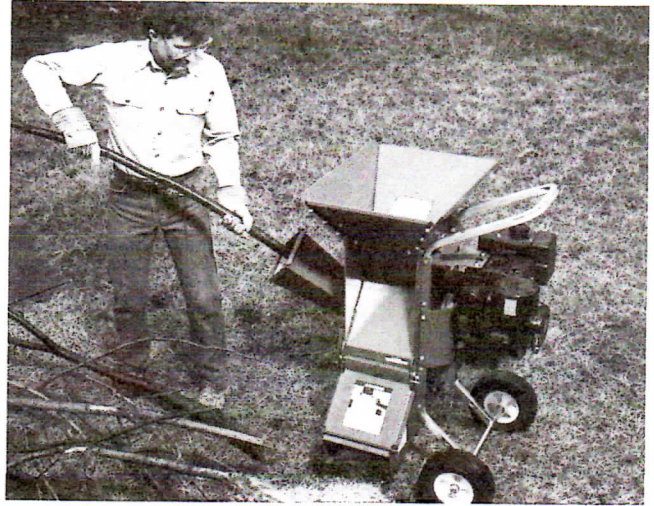

(Photo 4-4) If engine speed starts to slow, reduce feed pressure and let engine speed build up.

How To Use The Shredder

Once the engine on your equipment has been started and the Clutch Lever moved DOWN to the "ENGAGE" position, the flail cutter blades inside the Chipper/Shredder chamber will begin to revolve at a high rate of speed and the Shredder is ready to use. Of course, you must wear your safety goggles, sturdy work gloves, and hearing protection.

Stand 1-to-2 feet from the Shredder Feed Hopper in the "Operating Zone" as shown in Photo 4-5. You'll be facing the Operating Instruction decal inside the shredder hopper. Don't feed material in if you're not in this zone. Use the Leaf Tamper to push leaves down into the shredder chamber. The Leaf Tamper is designed with a "STOP" that prevents the end of the tamper from being struck by the flails. **IMPORTANT:** Hold the tamper so the "STOP" faces UP as shown in Photo 4-6.

DANGER

CONTACT WITH ROTATING CUTTING BLADES WILL CAUSE SERIOUS PERSONAL INJURY.

BLADES ROTATE WHEN ENGINE IS ON AND KEEP HANDS, FEET AND CLOTHING AWAY FROM THE CHIPPER CHUTE, SHREDDER FEED HOPPER AND THE DISCHARGE OPENING WHEN MACHINE IS RUNNING.

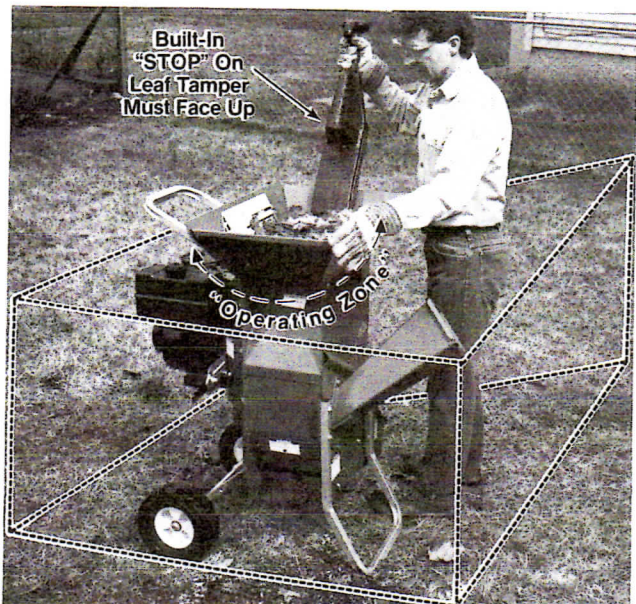

(Photo 4-5) When using the Shredder, stand 1-to-2 feet away from the top-loading hopper and release materials into it from any position within the "Operation Zone".

A steady flow of materials into the Shredder Feed Hopper provides the most effective results. See Photo 4-6. The rate of feed for branches, vines and brush can be controlled by lightly pushing and guiding the far end of material until it extends above the top of the hopper. At this point, **LET GO OF THE MATERIAL.** Use your tamper to push the material if necessary. It's best to cut long branches and vines into more manageable 3-to-5 foot lengths.

IMPORTANT — The shredder blades can tug suddenly at material being fed into the Shredder Feed Hopper, so don't hold on tightly to branches and vines, and don't feed material straight down into the hopper with your arm pointing downward toward the opening. Instead, keep your arms parallel to the ground and several inches above the top edge of the hopper.

Also: don't put any part of your body or clothing inside the hopper or near the discharge area; stand clear of the discharge area; and keep face and body back from the discharge opening.

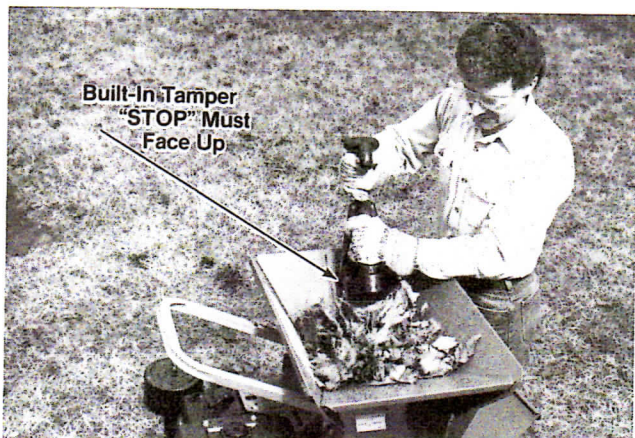

(Photo 4-6) Feed materials in steadily, but don't overload the shredder. Use the Leaf Tamper as shown above to push leaves down into the hopper.

Under certain conditions, it may become necessary to push bulky materials into the Shredder Feed Hopper. **DO NOT USE YOUR HANDS** — Instead, use a small diameter stick.

When you have loose materials to process, such as leaves, straw, or grass clippings, just drop them into the hopper opening, then push them past the retainer flap with your tamper. **Do not allow combustible materials to contact the engine. IMPORTANT** — If the engine slows down while feeding material, stop right away and give the engine time to come up to full speed.

Feed the shredder slowly until you are very familiar with its operation. Materials and conditions vary considerably. After a learning period, you will know how to process different materials best.

DANGER

THE DISCHARGE AREA AND DISCHARGE OPENING ARE DANGEROUS. SEE PAGES 4-5 FOR SAFETY INSTRUCTIONS TO AVOID INJURY.

All shredded material will be forced through the Discharge Screen and out the Discharge Tunnel at the side of your unit. Always keep clear of the discharge area since the materials exit with considerable velocity. The standard screen that came with your Chipper/Shredder is a perforated screen with 3/4" holes. This screen is best for processing most dry materials like brush and dry leaves.

Shredding Wet, Soggy, Green Materials

Wet or green materials (such as wet, matted leaves, gone-by vegetables, green vegetation like squash vines, etc.) will clog the 3/4" holes of the standard discharge screen.

Before shredding these types of materials, shut engine off, let all moving parts come to a complete stop, and disconnect spark plug wire; then remove the discharge screen from the machine and secure the service door with its rod and hairpin clip. You can now shred wet or green materials.

These types of materials will be shredded to a fine consistency when you follow this procedure. If you prefer an even finer consistency, you may wish to process the material a second time. NOTE: green cornstalks will be shredded into 3-4" chunks; reprocessing is recommended if you desire a finer material.

DO NOT use the optional Collection Bag when shredding wet or green material — doing so will cause clogging.

DANGER

WITH DISCHARGE SCREEN REMOVED, DO NOT SHRED BRUSH, BRANCHES, OR OTHER DRY MATERIALS — THEY WILL EXIT THE DISCHARGE OPENING AT HIGH SPEED.

SECTION 5:

Maintenance & Service

Engine Maintenance/Service

Your TROY-BILT® SUPER TOMAHAWK Chipper/ Shredder is equipped with one of several engine options. All are four-cycle, air-cooled, and gasoline powered. DO NOT MIX OIL WITH YOUR GASOLINE. Read and follow all of the service and maintenance information given here and in the accompanying engine manufacturer literature to keep the engine running at peak performance. If you need engine repairs or parts, contact your local authorized Briggs dealer or Tecumseh dealer. The dealer will need to know the engine identification numbers. Briggs & Stratton engines have MODEL, TYPE AND CODE NUMBERS; Tecumseh engines have MODEL AND SERIAL NUMBERS. Look on top of the engine blower housing, near the spark plug, per Photo 5-1.

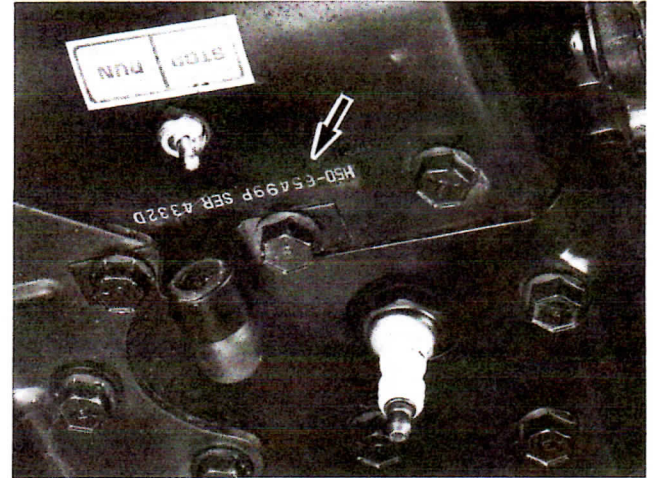

(Photo 5-1) Location of Tecumseh engine I.D. numbers. Briggs & Stratton I.D. numbers are in similar location.

WARNING

MOVING PARTS ON YOUR EQUIPMENT CAN CAUSE SERIOUS PERSONAL INJURY. SHUT OFF THE ENGINE, LET ALL MOVING PARTS STOP COMPLETELY, AND DISCONNECT THE SPARK PLUG WIRE BEFORE MAINTENANCE OR SERVICE PROCEDURES ARE PERFORMED.

Remember to check the engine oil level prior to each use and at least every two hours during continuous operation. The oil level must always be up to the "Full" mark on the 5HP Tecumseh dipstick and at the top of the oil fill tube on the 4HP Tecumseh and 8HP Briggs & Stratton engines.

Oil Change Schedule For Your Engine
 Initial Oil Change — After First 2 Hours of Operation
 Schedule Thereafter — Every 10 Hours of Operation

To Change The Engine Oil On The 8HP Briggs & Stratton Engine, Or The 4HP and 5HP Tecumseh Engines:

1. Run the engine a few minutes to warm the oil. Then stop the engine and disconnect the spark plug wire.
2. The Briggs & Stratton and the Tecumseh engines have two oil drain plugs on opposite sides of the engine near the engine base. Either drain plug may be used. Photo 5-2 shows a 5HP Tecumseh drain plug — the drain plug location is similarly located on the Briggs engines and other Tecumseh engines.

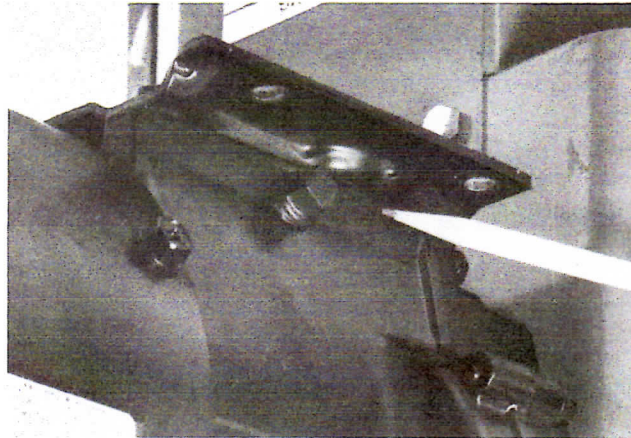

(Photo 5-2) Left-side oil drain plug location on Tecumseh engine. Similarly located on the Briggs engines.

3. On all Briggs & Stratton engines and the 4HP Tecumseh engines: clean thoroughly around the Oil Fill Cap, then remove the fill cap to vent crankcase for fast drainage. On the 5HP Tecumseh engine: clean around the Dipstick, then remove the dipstick on top of the engine. Also — prop up one wheel with a wood 2" x 4" on the opposite side of the engine from which you'll be draining the oil.
4. Place an oil collection pan beneath the Oil Drain Plug. Now remove the drain plug and allow all the dirty oil and sludge to drain out completely. Replace the drain plug — put gasket sealant on the threads. You're now ready to add fresh oil. In the 4HP Tecumseh and 8HP Briggs engines: add oil until the level is right up to the top of the Oil Fill tube (see Photo 2-7 or 2-8). Replace the oil fill cap. In the 5HP Tecumseh engine: add oil until the level is up to the "Full" mark on the dipstick atop the engine (about 19 ounces — see Photo 2-6). See Page 8 for oil specifications. Replace the dipstick.
6. Start the engine outdoors and let it warm up. Check the level again and be sure there is no leakage around the drain plug. If leaking, tighten it.

Air Cleaner Service

The air cleaner prevents dirt and dust from entering the engine through the carburetor. It is very important that the air cleaner filter be replaced if dirty, and properly installed at all times. This will prevent premature wear or damage to the engine. A clean filter also avoids starting and overheating problems.

8HP Briggs & Stratton Air Filter Service Schedule & Replacement Procedure:

Service Schedule — Inspect and clean “dry” filter every 3 months or 25 operating hours. See engine literature for cleaning instructions. Replace the filter annually or every 100 operating hours (all 8HP versions).

To Replace Air Filter — 1) Remove external wing nut from air cleaner outer cover and remove cover (see Photo 5-3); 2) Remove wing nut securing paper cartridge air filter and lift filter off; 3) clean outer cover and plate on which filter sits; 4) install new filter, its wing nut, outer cover and the external wing nut. NOTE: The 8HP I/C engine has an additional outer foam filter.

5HP & 4HP Tecumseh Air Filter Service Schedule & Replacement Procedure:

Service Schedule — Inspect filter every 10 operating hours, sooner if needed. See engine literature for full instructions. Replace the filter annually, or more often with extremely dusty or dirty conditions.

To Replace Air Filter — 1) Loosen both outer screws holding air cleaner cover in place; 2) Twist cover to the left, then remove cover with the air filter inside it (see Photo 5-4); 3) Check tightness of mounting screws on back mounting plate (Photo 5-4); 4) Clean the back plate and the outer cover, then install the new air filter and reassemble the components.

Engine Cooling Fins

Your equipment has an air-cooled engine, so it is important that air be able to circulate freely to keep the engine cool while running. To prevent a fire hazard, always remove dirt, grass and debris from the following areas: the cooling fins; engine covers; the air intake screen just behind the starter rope. Use a brush for thorough cleaning regularly. See Figure 5-5.

Spark Plug And Ignition System

8HP Briggs & Stratton Specifications — Use a Champion RCJ-8 spark plug or its equivalent. Clean and re-set spark plug gap (to .030”) annually or every 100 operating hours. Do not blast clean the spark plug. If spark plug is damaged or badly worn, please install a new plug. Your engine has no ignition tune-up — it has the Magnetron™ ignition which eliminates condenser and points.

5HP and 4HP Tecumseh Specifications — Use a Champion J-8 or the equivalent. Proper electrode gap is .030”. (Note: Canadian owners must use a Champion RJ-17LM Resistor Plug to comply with government

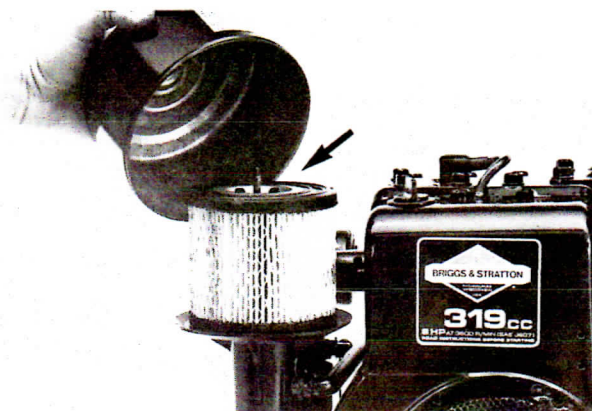

(Photo 5-3) Briggs & Stratton 8HP single-element paper cartridge air filter. (The 8HP I/C engine has a dual-element design — an outer foam filter and an inner paper cartridge.)

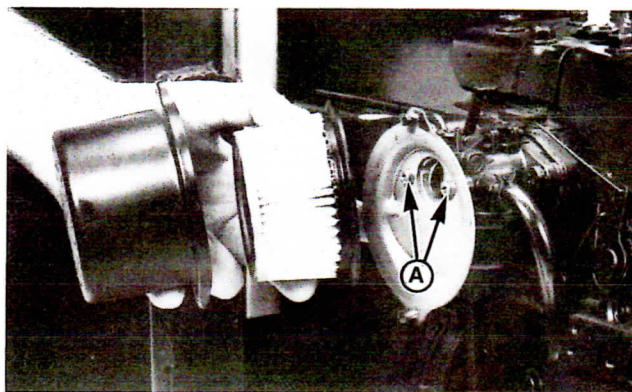

(Photo 5-4) 5HP Tecumseh air filter. Note screws (“A”) in back mounting plate — they must be tight. (4HP — same design.)

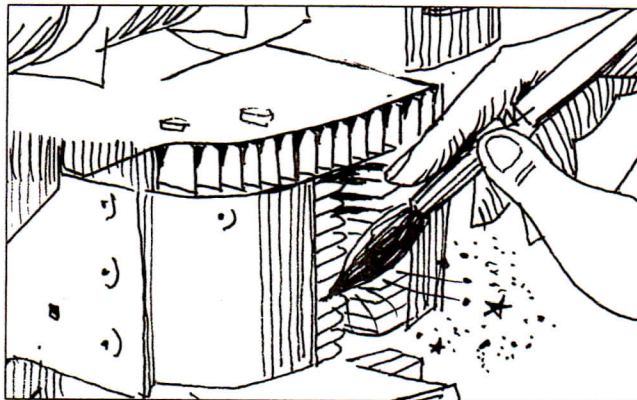

(Figure 5-5) Keep the engine cooling fins clean to prevent a potential fire hazard.

standards.) Your engine has a dependable, maintenance-free solid-state ignition, eliminating the need for points and condenser.

For further information on spark plugs and ignition systems, see separate engine manufacturer literature.

Carburetor Adjustment, Engine Storage & Other Engine Maintenance

Please refer to the engine manufacturer brochure which was included in your literature package for further details on topics such as carburetor adjustment, etc. Remember: your closest authorized engine dealer is fully equipped to handle all repairs, provide parts and engine warranty service.

Chipper/Shredder Maintenance And Service

WARNING

MOVING PARTS ON YOUR EQUIPMENT CAN CAUSE SERIOUS PERSONAL INJURY.

SHUT OFF THE ENGINE, LET ALL MOVING PARTS STOP COMPLETELY, AND DISCONNECT THE SPARK PLUG WIRE BEFORE MAINTENANCE OR SERVICE PROCEDURES ARE PERFORMED.

Lubrication Recommendations

An all-purpose spray-type lubricant should be used several times a year to keep moving parts in good condition and operating smoothly. Apply lubricant to these areas: **1)** the Clutch Lever (see Photo 5-6); **2)** the wheels and axle spacers (refer to Photo 5-7); **3)** the Belt Tension Adjustment Bolt (Photo 5-8). Note: a good quality grease containing a metal lubricant may be substituted for the spray-type lubricant.

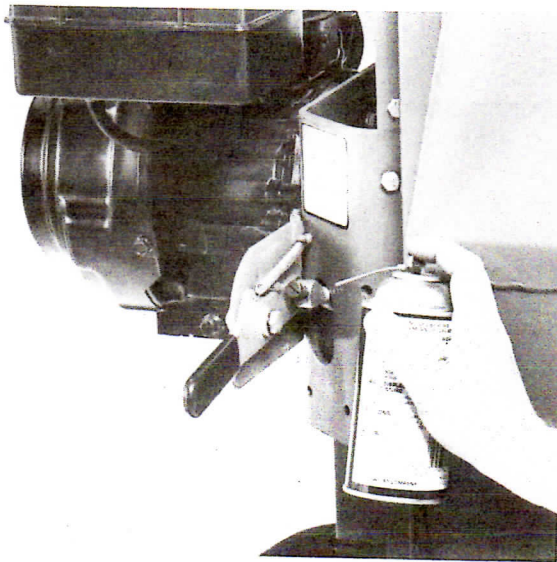

(Photo 5-6) Apply a good spray-type lubricant to the Clutch Lever. Move the lever while applying the lubricant.

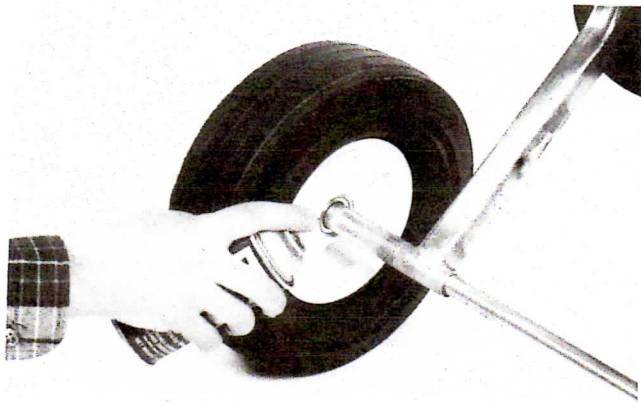

(Photo 5-7) The wheels and axle spacers should also be lubricated regularly.

Belt Tension Adjustment & Replacement

The belt on your Chipper/Shredder is a quality, heavy-duty belt. To perform correctly, however, it must be aligned and have the correct tension applied by the Belt Tension Adjustment Bolt (controls idler pulley tension against belt). Belt tension is Factory pre-set with this bolt. The setting should be good for the life of the belt. However, we suggest you check belt tension twice a year and make an adjustment if necessary.

To Check And Adjust Belt Tension: Tools Required — one flatblade screwdriver (if adjustment bolt has a slotted head); or an adjustable wrench (if head not slotted).

Shut engine off and disconnect the spark plug wire. Move the Clutch Lever to the "ENGAGE" position (move it downward). Next, measure the distance from the bottom of the bolt head to the bushing it passes through — this distance was Factory pre-set at 3/4"-to-13/16". As the belt wears over time, this distance will gradually decrease. If the gap ever decreases to less than 1/4", adjust the bolt to make the gap approximately 3/8". Turn it counterclockwise.

This is the only way in which full engine power can be transferred properly to the cylinder assembly. See Photo 5-8 for reference. **NOTE:** once an adjustment needs to be made, it is advisable from there on in to check this gap more frequently (every season), and if another adjustment is ever needed, the belt should be replaced at that time. We suggest you order a new belt from us and plan to install it on arrival. Belt replacement instructions are found on the next page.

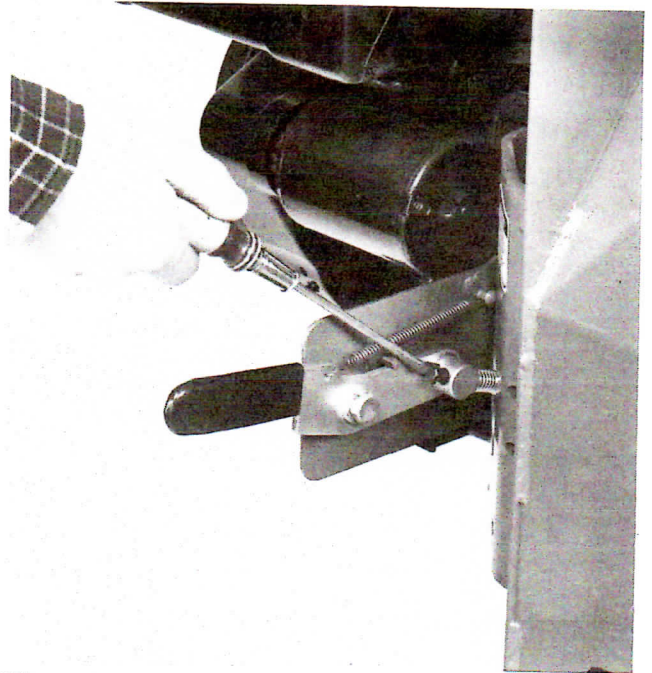

(Photo 5-8) Belt Tension Adjustment Bolt determines amount of tension applied to drive belt through the Clutch Lever and idler pulley. If gap between bolt head and bushing ever decreases to less than 1/4", adjust bolt out to make gap 3/8". Clutch Lever must be in "ENGAGE" position when making this adjustment.

Belt Replacement Instructions:

Tools Required —

One flathead screwdriver or an adjustable wrench
(for belt tension adjustment bolt)

Two 7/16" open end wrenches (for belt cover)

WARNING

MOVING PARTS ON YOUR EQUIPMENT CAN CAUSE SERIOUS PERSONAL INJURY.

SHUT OFF THE ENGINE, LET ALL MOVING PARTS STOP COMPLETELY, AND DISCONNECT THE SPARK PLUG WIRE BEFORE MAINTENANCE OR SERVICE PROCEDURES ARE PERFORMED.

If the drive belt on your equipment is worn out or damaged (chipped, cracked, abnormally frayed or torn), please replace the belt right away. A damaged belt is obvious. Whether a belt is too badly worn can be checked by the belt tension adjustment procedure on the previous page. Please contact us for another belt — the correct belt length is very important, and your belt has special high-strength properties. **NOTE:** on initial start-up when your unit is brand new, the belt will lose some black rubber compound because it's a "raw edge" belt. This is normal and not a sign of belt wear. A mild solvent will remove any black rubber compound that may have been deposited on painted surfaces.

1. Shut the engine OFF. Allow all moving parts to stop completely. Then disconnect the spark plug wire from the spark plug. This prevents the chance of accidental engine starting while you're working.
2. Move the Clutch Lever up to "DISENGAGE".
3. Next, remove the belt cover (shield) below the engine which covers the lower drive pulley and the belt. See Photo 5-9. Just remove the two bolts and locknuts that hold the cover in place (use 7/16" wrenches).

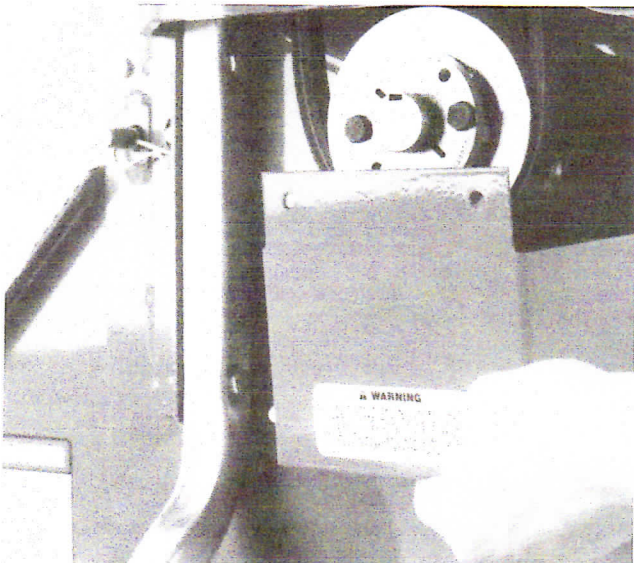

(Photo 5-9) Remove the belt cover held in place by two bolts and locknuts. The lower pulley and drive belt are behind it.

4. Look down between the rear of the engine and the chipper/shredder steel wall. You can see the drive belt around the upper pulley (engine pulley) and the lower pulley (driveshaft pulley). You'll also see the idler pulley between the other two pulleys — the idler pulley is what puts tension on the drive belt when the Clutch Lever is moved to the "ENGAGE" position (DOWN). Remove the belt from the lower (driveshaft) pulley first because it's the fastest and easiest way. To do this, kneel next to the lower pulley, then turn the pulley (rotate it) with one hand while using your other hand to "ride" the belt off the pulley. See Photo 5-10.

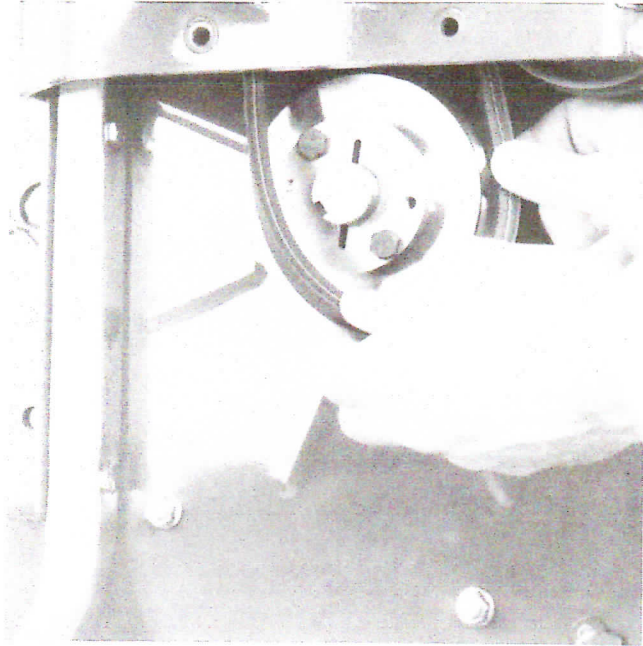

(Photo 5-10) Turn (rotate) the lower pulley with one hand and use your other hand to guide the belt off the pulley. The rest of the job is easy.

Once the belt is off the lower pulley, move the belt away from the idler pulley (see Photo 5-11), then upward and off the upper pulley (see Photo 5-12). You can now remove the belt from your equipment.

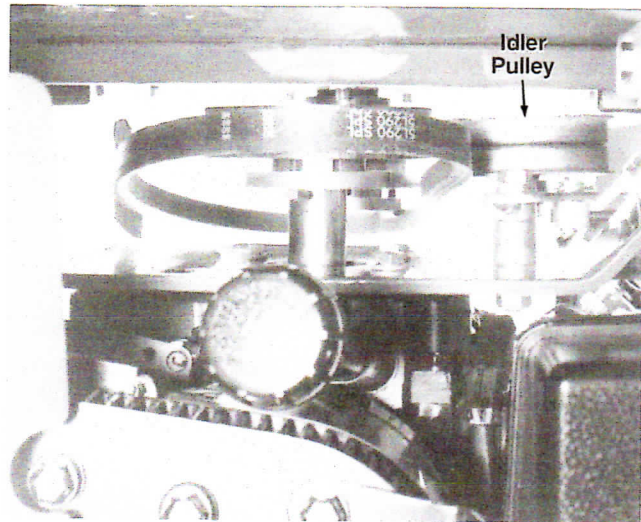

(Photo 5-11) Work the belt away from the idler pulley.

5. To install a new belt, just reverse the steps you took to remove the old belt. Insert the new belt from the bottom of your equipment. Position it first over the upper pulley. Make sure it's positioned properly alongside the idler pulley. Then "ride" the belt back on the lower pulley by turning the lower pulley as you guide the belt on. See Photo 5-13.

Once the new belt is on, make sure the tension on the belt is correct. Move the Clutch Lever to "ENGAGE"

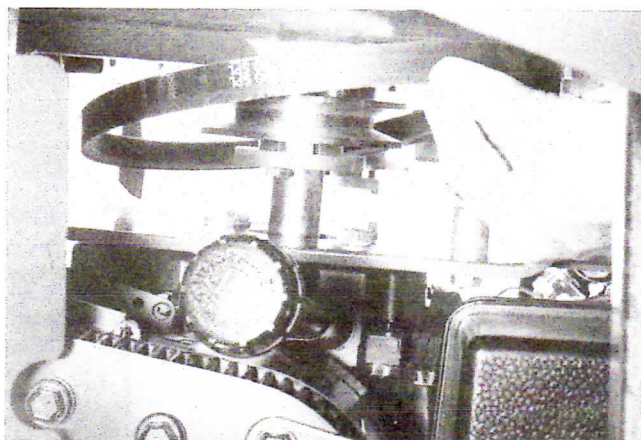

(Photo 5-12) Push old belt upward and off the top pulley.

(DOWN) (engine must be OFF). Measure the gap between the bottom of the Belt Tension Adjustment Bolt head and the bushing next to it. Turn the bolt to make the gap between them 3/4"-to-13/16". Don't forget to replace the belt cover securely, and then to reconnect the spark plug wire. The job is done.

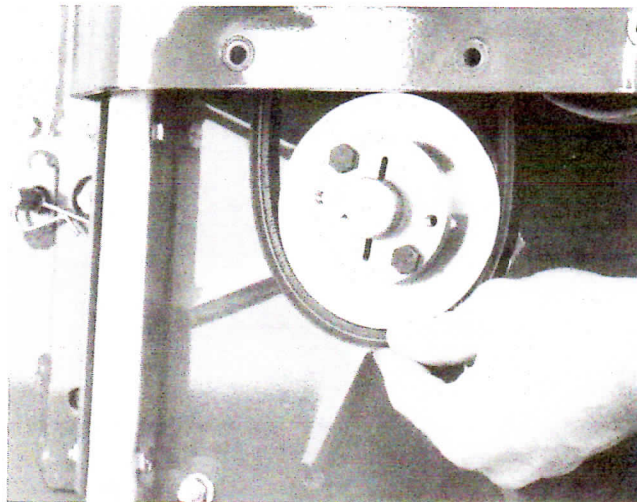

(Photo 5-13) Once the new belt is on the upper pulley and positioned alongside the idler pulley, guide it back on the lower pulley. Use pulley rotation to assist you if necessary.

How to Rotate or Replace the Shredder Cutting Blades (Flails)

WARNING

MOVING PARTS ON YOUR EQUIPMENT CAN CAUSE SERIOUS PERSONAL INJURY.

SHUT OFF THE ENGINE, LET ALL MOVING PARTS STOP COMPLETELY, AND DISCONNECT THE SPARK PLUG WIRE BEFORE MAINTENANCE OR SERVICE PROCEDURES ARE PERFORMED.

The shredder cylinder assembly has 16 steel cutting blades (12 on the 4HP model) that do the shredding inside the shredder chamber. Each blade has four cutting edges, as shown in Figure 5-14.

Only one edge on each blade does the cutting. When that edge dulls, the blade can be removed and rotated so that one of the other three edges can be put to work. To rotate the blades (or to replace the blades), use the following procedure.

Tools required: 5/32" and 7/32" dia. non-tapered pin punches, 12" drift pin, ball peen hammer, adjustable pliers, flat blade screwdriver, Phillips screwdriver, 1/2" wrench, flashlight, awl or small nail, 4-foot length of 2 x 4 board, penetrating lubricant (such as WD-40), and a clean can or pail (to collect gasoline from engine). You will also need a new roll pin (Part No. 11536) for each row of cutting blades you will be working on (there are four separate rows), and a tube of Loctite 242 thread-locking compound.

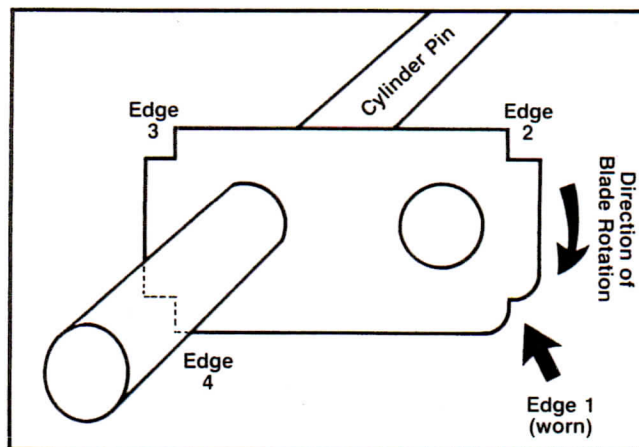

(Figure 5-14) There are four cutting edges on each blade. When an edge becomes dull (as shown by Edge 1 above), that blade can be removed and rotated to use one of the remaining sharp edges.

Disassembly Steps:

1. Stop the engine, wait for all moving parts to stop, and disconnect the spark plug wire. On electric start models, disconnect the negative cable at the grounding point on the axle bracket.
2. To inspect the cutting blades, first remove the hairpin and rod that secure the service door (see Photo 5-15). Next, remove the two hairpins and rods that secure the discharge screen. Finally, lift the door and remove the discharge screen. With the door open, rotate the cylinder assembly to inspect all of the blades and spacers (a flashlight will be helpful).

Note: Unit Must Be Off,
All Parts Stopped And
Spark Plug Disconnected

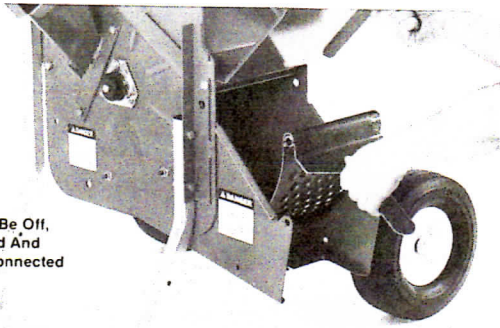

Next, Remove
Hairpins And
Rods At Front
And Rear Of
Screen

First Remove Hairpin
And Rod Locking Front Of
Service Door

(Photo 5-15) To remove discharge screen, first remove hairpin and rod securing service door. Then take out the two hairpins and rods securing the screen.

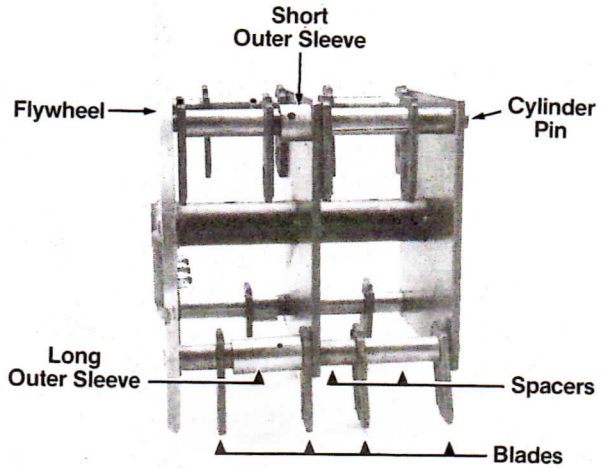

(Photo 5-16) View of cylinder assembly used with 5HP and 8HP model chipper/shredders (assembly is shown removed from shredder chamber for photo purposes only).

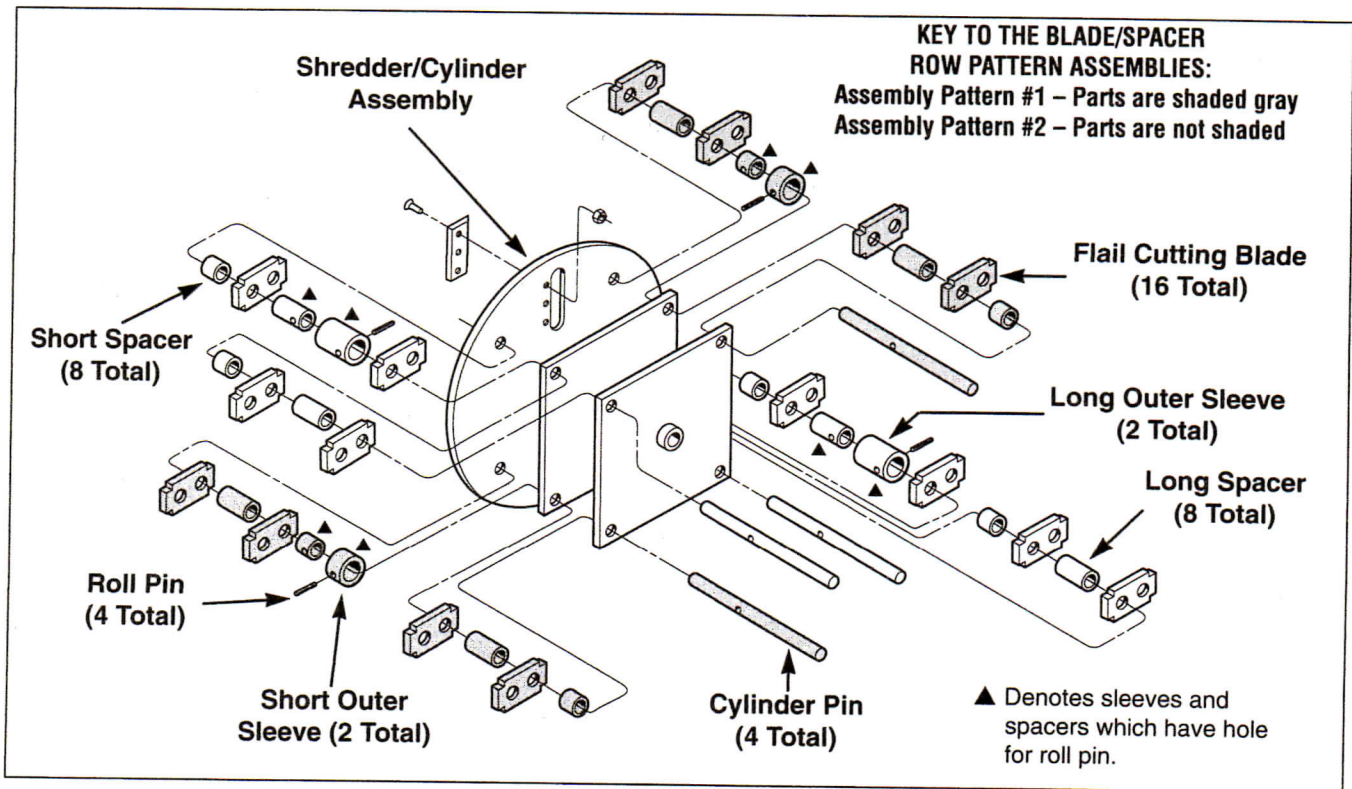

(Figure 5-17) The chipper/shredder cylinder assembly for 5HP and 8HP models is shown above (the 4HP model has fewer blades and spacers). Two different patterns are used to assemble the blades and spacers on the four cylinder pins — it is critical that the parts be reassembled correctly. If you have a 4HP model, refer to your Parts Catalog for an illustration showing the correct blade/spacer patterns.

3. Each row of cutting blades is mounted on a cylinder pin. The blades are held in position by short and long spacers (see Photo 5-16 and Figure 5-17). The blades and spacers are secured to the cylinder pin by a roll pin that fits through one of the spacers. That spacer is covered by an outer sleeve which prevents the roll pin from working free in normal operation. If the cutting blades, spacers, and sleeves appear to be in good condition, reassemble the machine. Otherwise, continue with Step 4.

CAUTION

THE CHIPPER BLADE IS EXTREMELY SHARP AND CAN CAUSE PERSONAL INJURY.

AVOID CONTACT WITH THE BLADE (WHICH IS MOUNTED ON THE CHIPPER FLYWHEEL).

4. Use the flat blade screwdriver to pry out the round conduit plug located to the right side of the belt guard (see Photo 5-18).

5. Using a 1/2 in. wrench, remove the chipper chute by removing the four 5/16"-18 x 5/8" screws and 5/16" lockwashers that secure the chute to the main frame. See photo 5-22 on Page 34.

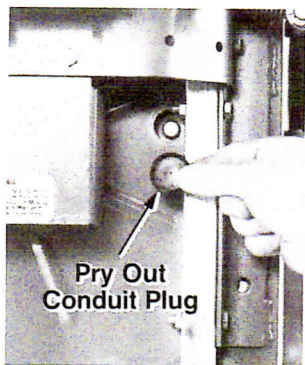

(Photo 5-18) Pry out conduit plug with a screwdriver.



(Photo 5-19) Remove discharge tunnel.

6. Using a Phillips screwdriver and a 1/2 in. wrench, remove the discharge tunnel by removing the six 5/16"-18 x 3/4" Phillips screws and 5/16" flanged locknuts (three on each side of tunnel) that secure the tunnel to the main frame. See Photo 5-19.

7. Due to the limited work area inside the machine, the remaining steps should be performed with the machine laying on the floor, with the discharge tunnel side facing up. Do not lay the machine on its side until you follow these steps:

- a. TO AVOID A POTENTIAL SAFETY HAZARD DUE TO SPILLED GASOLINE, THE FUEL TANK MUST BE COMPLETELY EMPTIED OF ALL GASOLINE BEFORE THE MACHINE IS LAID ON ITS SIDE. To drain the gasoline, use adjustable pliers to squeeze the tabs on the hose clamp at the point where the fuel line is connected to the carburetor fuel line fitting. Slide the clamp down the fuel line. Pinch the fuel line with your fingers so gasoline won't run out, and gently pull the fuel line off the fitting. Drain the gasoline and store it in a safety-approved gasoline can. After draining, install the fuel line on the carburetor fitting and secure it in place with the hose clamp.

! DANGER

GASOLINE AND ITS VAPORS ARE HIGHLY FLAMMABLE AND EXPLOSIVE.

TO AVOID SERIOUS PERSONAL INJURY, BE SURE AREA IS WELL VENTILATED AND KEEP AWAY FROM OPEN FLAME OR SPARKS. OBSERVE NO SMOKING RULES AT ALL TIMES.

- b. TO AVOID A POTENTIAL SAFETY HAZARD DUE TO SPILLED BATTERY ELECTROLYTE, THE BATTERY MUST BE REMOVED FROM THE MACHINE BEFORE THE MACHINE IS LAID ON ITS SIDE. To remove the battery, follow the "Battery Removal and Replacement Instructions" on Page 40.

! DANGER

IMPROPER HANDLING OF THE BATTERY CAN RESULT IN ELECTRICAL BURNS, AN ELECTRIC SHOCK, OR AN EXPLOSION OF BATTERY GASES. TO HELP AVOID INJURY:

- **KEEP SPARKS AND FLAMES AWAY.**
- **DO NOT TOUCH EITHER BATTERY POST SIMULTANEOUSLY WITH TOOLS, JEWELRY, OR OTHER METAL OBJECTS.**

c. To avoid a possible oil leak from the engine while the machine is laying on its side, it is recommended that you drain the oil from the engine crankcase. Doing so will also prevent the oil from collecting in the engine cylinder area, possibly causing the engine exhaust to smoke heavily until the oil burns off. To drain the oil, refer to the instructions on Page 26.

d. After performing Steps a, b, and c, gently lay the machine down on the side opposite the discharge tunnel.

8. Rotate the cylinder assembly slowly until the blade/ spacer row that holds the worn blade(s) is facing you. Carefully note how the shredder blades and spacers are arranged.

9. Remove the blades and spacers as follows:

a. Prevent the cylinder assembly from moving by wedging it in place with a length of wood fed in through the shredder hopper.

b. Locate the outer sleeve (the larger diameter spacer having a large and small hole in it). Clean out the holes in the sleeve with an awl or a sharp nail. If the sleeve does not spin easily, soak it thoroughly with penetrating lubricant, making sure the lubricant enters the two holes.

c. Rotate the outer sleeve until the SMALL hole is facing you. Then, align the small hole with the roll pin in the inner spacer (if necessary, rotate the cylinder pin, which will rotate the inner spacer).

d. Put on safety goggles to protect your eyes. Then, using a hammer and a 5/32" pin punch, drive the roll pin out through the LARGE hole in the outer sleeve.

- e. Throw away the used roll pin. **For safety, you must use a new roll pin when the parts are reassembled.** Also, remove the length of wood after the roll pin is removed.
- f. Rotate the cylinder assembly until the cylinder pin that is to be removed is aligned with the conduit hole. Put on safety goggles to protect your eyes. Then, using a hammer and a long drift pin, slowly drive the cylinder pin out through the chipper chute hole on the opposite side (see Figure 5-20). The blades, spacers and outer sleeve will drop off the pin as it moves outward. (If necessary, soak any stubborn parts with penetrating lubricant.) To ensure proper reassembly, carefully arrange the parts in the exact order they come off. Discard any damaged parts and replace them with new ones (refer to your Parts Catalog for parts ordering information).
- g. A worn blade can now be turned end-to-end, or flipped over, so that a new cutting edge is in position for reassembly.

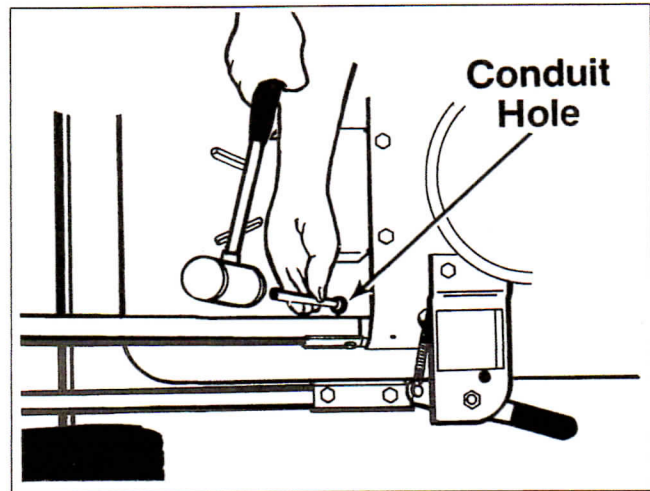

(Figure 5-20) Rotate cylinder assembly to align appropriate cylinder pin with the conduit hole. Drive cylinder pin out through chipper chute hole on opposite side of machine.

Reassembly Steps:

IMPORTANT: TWO DIFFERENT PATTERNS (SEE FIGURE 5-17 FOR 5HP AND 8HP MODELS OR YOUR PARTS CATALOG FOR 4HP MODELS) ARE USED TO ASSEMBLE THE CUTTING BLADES AND SPACERS ON THE FOUR CYLINDER PINS. CAREFULLY FOLLOW THE CORRECT ASSEMBLY PATTERN FOR EACH CYLINDER PIN ROW.

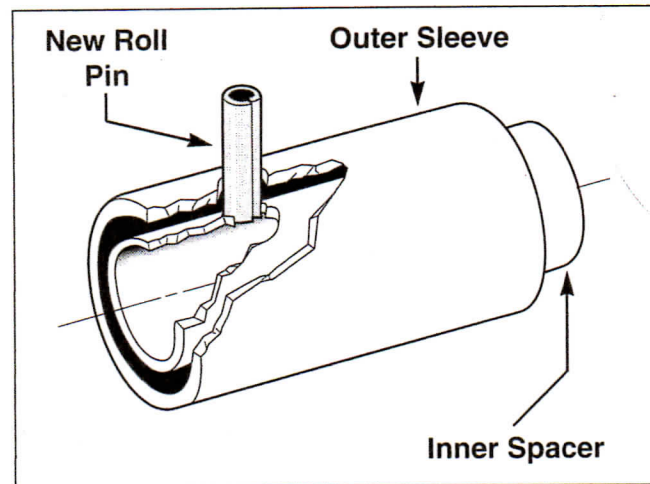

(Figure 5-21) Preassemble inner space and outer sleeve with a NEW roll pin.

WARNING

THE CYLINDER PIN ROWS MUST BE PROPERLY ASSEMBLED AND THEN SECURED WITH A NEW ROLL PIN BEFORE THE CHIPPER/SHREDDER IS PLACED IN OPERATION.

FAILURE TO PROPERLY ASSEMBLE OR SECURE THE CYLINDER ROWS COULD RESULT IN SERIOUS INJURY TO THE OPERATOR OR BYSTANDERS.

1. Before reassembling the parts, clean them thoroughly. Inspect for and remove any burrs that could prevent the parts from fitting together.
2. Locate the outer sleeve and inner spacer that have roll pin holes in them. Preassemble the sleeve and spacer with a NEW roll pin as follows:
 - a. Slide the inner spacer into the outer sleeve and align the LARGE hole in the sleeve with the holes in the spacer.

- b. Apply a coating of Loctite 242 thread sealant to one end of a NEW roll pin.
- c. Put on safety goggles to protect your eyes. Then, using pliers to hold the roll pin, tap the end that is coated with Loctite 242 through the LARGE hole in the sleeve and into the top hole in the spacer (see Figure 5-21). **DO NOT** drive the roll pin all the way through the top hole in the spacer. Stop when the roll pin is flush with the bottom edge of the hole (going further will prevent the spacer from fitting over the cylinder pin).

3. Insert the cylinder pin through the hole for the chipper chute and reassemble the blades and spacers, one at a time, as you slowly feed the pin through the cylinder assembly.
4. Prevent the cylinder assembly from moving by wedging it with a length of wood.

5. Finish installing the roll pin as follows:
 - a. Rotate the cylinder pin until the hole in the pin is aligned with the roll pin in the preassembled sleeve and spacer.
 - b. Coat the exposed portion of the roll pin with Lock-tite 242 thread sealant.
 - c. Reach behind the blade/spacer row and hold the cylinder pin, spacer and sleeve in alignment by inserting a 5/32" pin punch through the empty holes.
 - d. While wearing safety goggles, use a hammer to tap the roll pin down until it is flush with the surface of the outer sleeve. Then, using a 7/32" pin punch, drive the roll pin in until it is flush with the holes in the inner spacer. **THE ROLL PIN SHOULD NOT PROTRUDE BEYOND THE HOLES IN THE INNER SPACER!**
 - e. The outer sleeve must spin freely. If it doesn't, check to make sure that the roll pin is not protruding beyond the edges of the inner spacer.
 - f. Repeat the above steps with any other cylinder pin rows, as needed.

6. Replace the conduit plug.

7. With an assistant helping you, return the machine to its upright position.
8. Reinstall the discharge tunnel with its six Phillips screws and flange locknuts.
9. Reinstall the discharge screen and secure it with the two rods and hairpin clips.
10. Secure the discharge door with the rod and hairpin clip.
11. Reinstall the chipper chute with its four screws and lockwashers.
12. Reinstall the battery on electric start models (refer to instructions on Page 40).
13. Replace the oil in the engine.
14. Refill the fuel tank with gasoline.
15. Remove length of wood used to wedge cylinder assembly in place.

! DANGER

ROTATING CUTTING BLADES! DO NOT OPERATE MACHINE UNLESS DISCHARGE TUNNEL AND CHIPPER CHUTE ARE BOLTED IN PLACE.

Chipper Blade Replacement

Over time, the tempered steel chipper blade mounted on the revolving chipper flywheel will dull with hard use. You'll know if the blade needs sharpening when wood chips aren't as consistent in size and shape, or when branches take longer to process.

Tools Required: 1/2" open end wrench; 5/32" hex key wrench

1. The Spark Plug Wire Must Be Disconnected! First remove the Discharge Screen near the bottom of your equipment. Remove the hairpin and the rod so the Service Door can open. Take out the two hairpins holding the screen rods, slide the rods out, then put the screen aside. (Refer back to Photo 5-15.)

! DANGER

CONTACT WITH ROTATING CUTTING BLADES INSIDE YOUR EQUIPMENT WILL CAUSE SERIOUS PERSONAL INJURY.

SHUT OFF THE ENGINE, LET ALL MOVING PARTS STOP COMPLETELY, AND DISCONNECT THE SPARK PLUG WIRE BEFORE MAINTENANCE OR SERVICE PROCEDURES ARE PERFORMED.

2. Remove the four bolts and lockwashers securing the Chipper Feed Chute to the wall of the Chipper/Shredder chamber. Use a 1/2" wrench. Once the Chipper Feed Chute is off, put it aside. See Photo 5-22. Also take off the Discharge Tunnel at the bottom of your equipment — see Photo 5-23. Remove three screws on each side of the mainframe (chipper side and engine side) and the tunnel is disconnected. Put it aside.

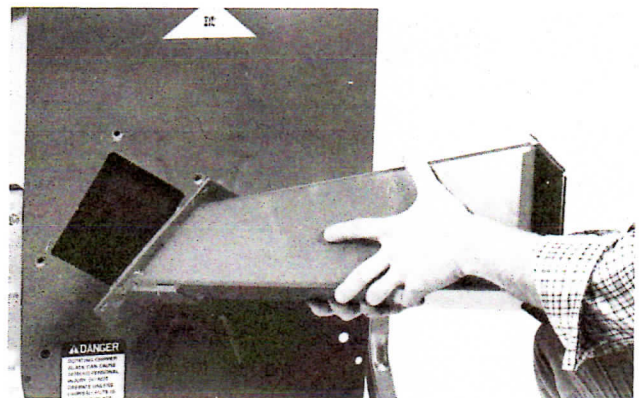

(Photo 5-22) Remove the Chipper Feed Chute which is secured with four bolts through the wall of the chamber. The Discharge Screen must also be removed.

3. You now have access to the chipper flywheel. Turn the flywheel (be sure Clutch Lever is in Disengage position) until the chipper blade comes into view. Move Clutch Lever to Engage position now. The chipper blade is secured with three socket-head screws as shown in Photo 5-24. Locknuts on the back side of the chipper flywheel hold the socket-head screws. Be sure to clean out the screw heads with a nail or ice pick.

CAUTION
CHIPPER BLADE IS EXTREMELY SHARP AND CAN CAUSE PERSONAL INJURY.
AVOID CONTACT WITH THE BLADE EDGE. HANDLE THE BLADE CAREFULLY.

4. Use your 1/2" open end wrench and your 5/32" hex key wrench to remove the hardware securing the chipper blade. Use a nail to clean out the socket heads on the screws first. Place the open end wrench up into the chipper/shredder chamber behind the flywheel and on the locknut closest to you. Position the hex key wrench in the appropriate socket-head screw. For leverage, you may wish to hold the hex key wrench steady with a pliers (regular type or clamping type) while loosening the locknut with the open end wrench. See Photo 5-25. Remove hardware and chipper blade.

5. Inspect the cutting edge of the blade carefully. If dull or nicked, it should be sharpened at a 45° angle (see Figure 5-26). Note — if you do not have sharpening experience and proper equipment, take the blade to a professional sharpening service in your local area. **If the blade is cracked or damaged, please replace the blade right away. Never use a cracked blade.**

6. Reinstall the sharpened or new blade with the three socket-head screws and lock nuts. **Tighten them firmly.**

7. Replace the Discharge Tunnel and Chipper Chute securely, and the Discharge Screen. Don't forget to reconnect the plug wire.

DANGER
ROTATING CUTTING BLADES! DO NOT OPERATE MACHINE UNLESS DISCHARGE TUNNEL AND CHIPPER CHUTE ARE BOLTED IN PLACE.



Note: Unit Must Be Off, All Parts Stopped And Spark Plug Disconnected

(Photo 5-23) Take off three screws on both sides of the shredder in order to remove the discharge tunnel. This gives you a lot more room to maneuver.

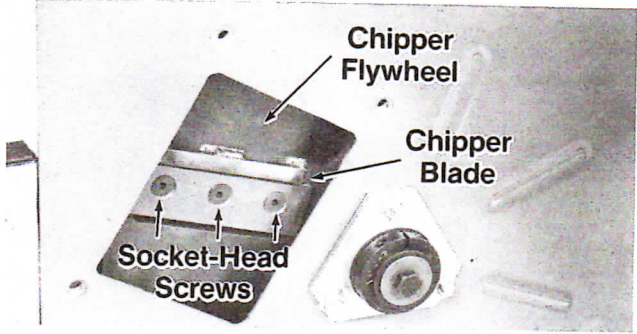

(Photo 5-24) Shown above are the chipper blade secured with socket-head screws and locknuts, and the chipper flywheel.

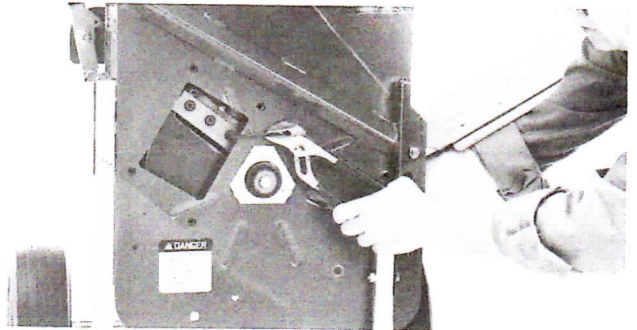

(Photo 5-25) Use 5/32" hex key wrench and a 1/2" open end wrench to take off hardware securing the chipper blade to the chipper flywheel.

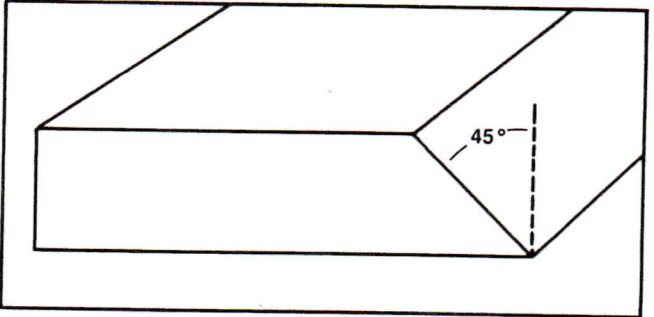

(Figure 5-26) The chipper blade should be sharpened at a 45° angle. A professional blade sharpener is recommended if you do not have this experience.

Regularly Inspect Hardware at End of Drive Shaft, in Bearing Locking Collars, and on Flangette Plates

The belt-driven cylinder drive shaft receives power from the engine and rotates at high speed, thereby turning the cylinder assembly that is bolted to the drive shaft.

The drive shaft is supported by and rotates within two bearings, one at each end of the drive shaft. To prevent the drive shaft from moving out of position within the two bearings, there are two bearing locking collars (which tighten with set screws) connected to the ends of the bearings, and a bolt in the chipper side end of the drive shaft. With constant use, this hardware can loosen. *Therefore, at least once a year, check all of the hardware listed below for tightness.*

Hardware to check (refer to Photos 5-27 and 5-28):

1) The locking collar set screws (on both sides of machine); **2)** the flangette whiz nuts (on both sides of machine); **3)** the bolt at end of drive shaft on chipper side of machine. *If any of this hardware is loose, there is a specific hardware tightening sequence that must be followed. Proceed as follows.*

Hardware Tightening Sequence: **1)** With a 1/8" hex key wrench, loosen the set screw in the locking collar on the chipper side of the machine (see Photo 5-27); **2)** Use a 1/2" wrench to loosen the three flangette nuts on the chipper side (Photo 5-27); **3)** Lower a 4-foot long broom handle or length of wood down through the shredder hopper and through the cylinder assembly — jamming it so the assembly can not revolve; **4)** With a 9/16" wrench, loosen the bolt in the chipper side end of the drive shaft (Photo 5-27); **5)** On the engine side of the machine, loosen the locking collar set screw and the three flangette nuts behind the lower drive pulley (Photo 5-28); **6)** To begin the hardware tightening procedure, first tighten the bolt in the chipper side end of the drive shaft (Photo 5-29), then *loosen* it one full turn (this centers the shaft and cylinder assembly inside the chamber); **7)** Fully tighten the locking collar set screw and the three flangette nuts on the chipper side (Photo 5-30); **8)** Fully tighten the bolt in the chipper side end of the drive shaft; **9)** Fully tighten the three flangette whiz nuts and the locking collar set screw on the engine side of the machine (Photo 5-31). When finished, remove the broom handle (or length of wood) from inside the machine.

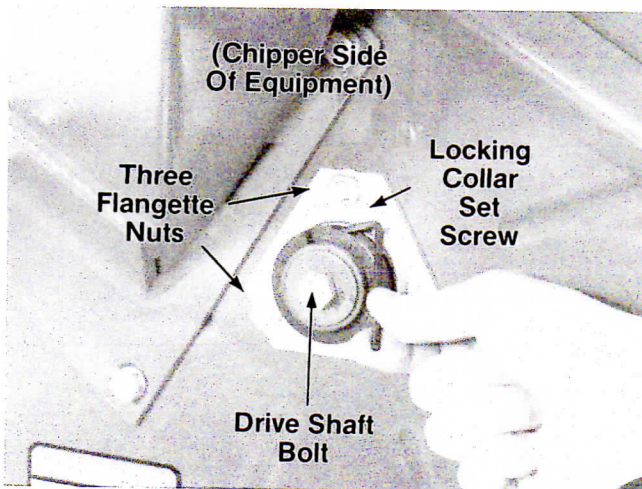

(Photo 5-27) This hardware is located on chipper side of machine. If hardware needs tightening, follow specific tightening procedure provided in text above.

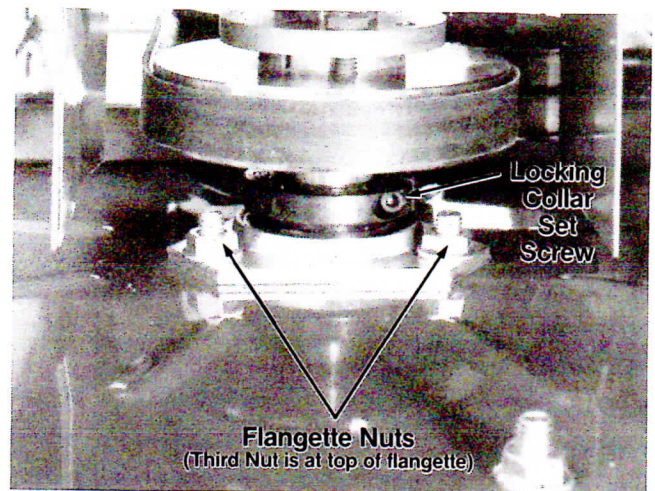

(Photo 5-28) This hardware is located on engine side of machine (belt cover must be removed for service). Hardware can be tightened without removing pulley.

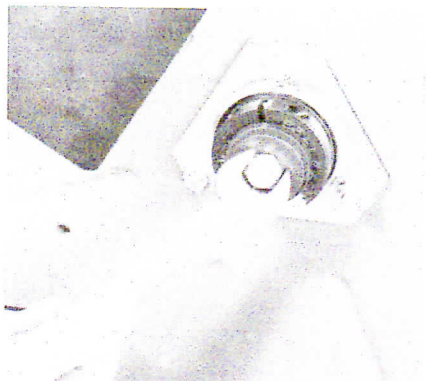

(Photo 5-29) Drive shaft bolt on chipper side of machine.

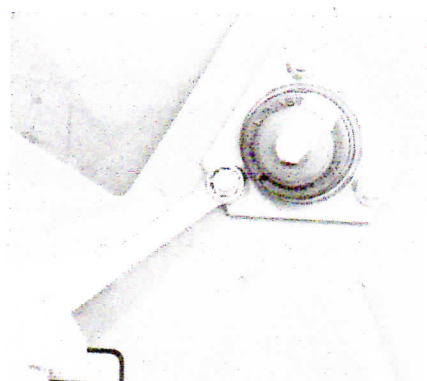

(Photo 5-30) Flangette nuts on chipper side of machine.

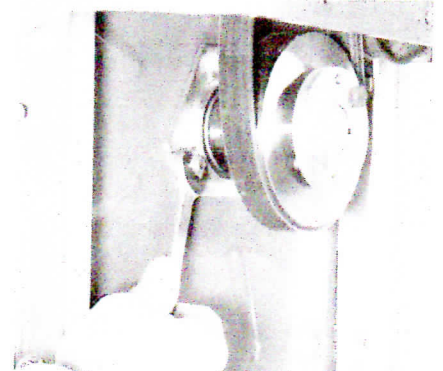

(Photo 5-31) Tighten flangette nuts and locking collar set screw on engine side of machine last.

Removing and Replacing the Drive Pulleys

WARNING

MOVING PARTS ON YOUR EQUIPMENT CAN CAUSE SERIOUS PERSONAL INJURY.

SHUT OFF THE ENGINE, LET ALL MOVING PARTS STOP COMPLETELY, AND DISCONNECT THE SPARK PLUG WIRE BEFORE MAINTENANCE OR SERVICE PROCEDURES ARE PERFORMED.

The following instructions explain how to remove and replace the engine drive pulley and the cylinder assembly drive pulley (see Figure 5-32).

The two drive pulleys are identical. Each consists of two parts — a single groove pulley and a detachable split bushing (see Figure 5-33). The pulley is attached to the bushing by two hex head screws. The bushing/pulley assembly is secured to the drive shaft by a compression fit that is attained by tightening the two screws, which draws the pulley inward along the tapered shank of the bushing.

Tools Required: two 7/16" open/boxed end wrenches, two 1/2" open/boxed end wrenches (if engine drive pulley is to be removed), one straightedge (such as ruler) at least 12" long, a 4-foot length of 2 x 4 board (if cylinder assembly drive pulley is to be removed), and a 2-foot length of 1/2 x 2 board (if engine drive pulley is to be removed).

Pulley Removal:

1. Stop the engine, wait for all moving parts to stop, and disconnect the spark plug wire. On electric start models, disconnect the negative cable at the grounding point on the axle bracket.
2. Remove the drive belt by following the "Belt Replacement Instructions" on Page 29.
3. If the engine drive pulley needs to be removed, then it is necessary to first remove the engine as explained in this Step. Otherwise, proceed to Step 4.

IMPORTANT: The 4HP and 5HP engines weigh approximately 30 to 40 lbs; the 8HP engine weighs approximately 50 lbs! To prevent personal injury or damage to the engine, have an assistant hold the engine securely while it is being removed and replaced. **BE SURE THAT THE MUFFLER IS COOL BEFORE TOUCHING THE ENGINE!**

- a. On electric start models, remove the battery by following the "Battery Removal and Replacement Instructions" on Page 40.

DANGER

IMPROPER HANDLING OF THE BATTERY CAN RESULT IN ELECTRICAL BURNS, AN ELECTRIC SHOCK, OR AN EXPLOSION OF BATTERY GASES. TO HELP AVOID INJURY:

- **KEEP SPARKS AND FLAMES AWAY.**
- **DO NOT TOUCH EITHER BATTERY POST SIMULTANEOUSLY WITH TOOLS, JEWELRY, OR OTHER METAL OBJECTS.**

- b. With an assistant securely holding the engine, use two 1/2 in. wrenches to remove the four 5/16"-18 x 1" screws and 5/16"-18 flanged locknuts that attach the engine mounting plate to the vertical side rails on the chipper/shredder main frame. See Photo 5-34.

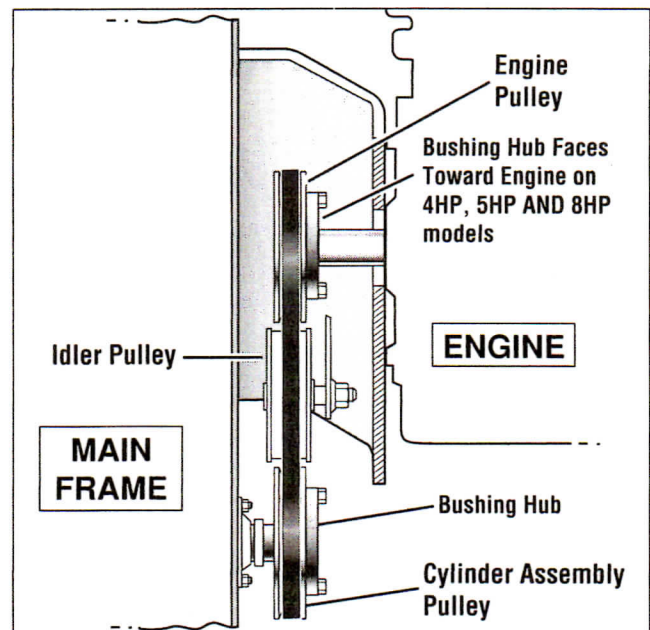

(Figure 5-32) The belt drive transmission parts are shown above.

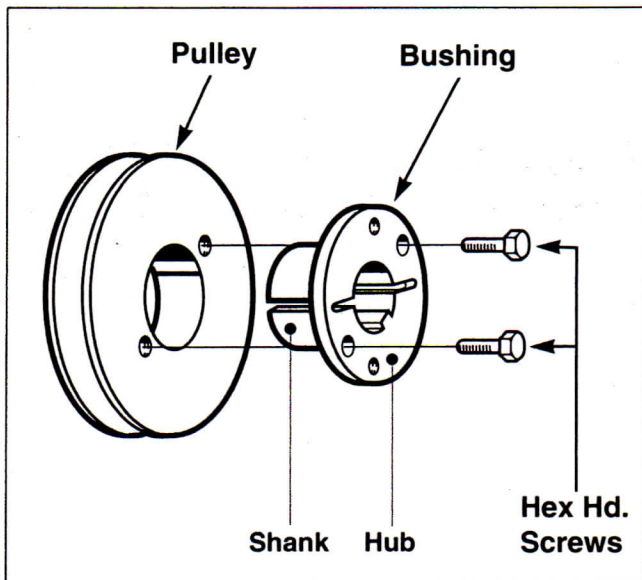

(Figure 5-33) Pulley and bushing assembly.

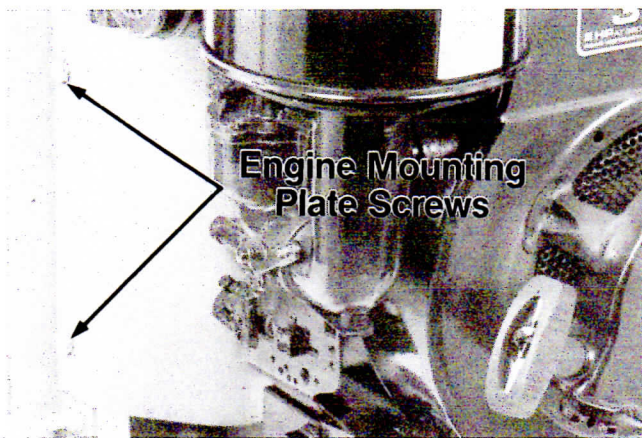

(Photo 5-34) To remove engine, take off four screws and nuts (two on each side of engine) that hold engine mounting plate to vertical rails on side of chipper/shredder.

4. While holding the pulley with one hand, use a 7/16 in. wrench to remove the two hex head screws (shown in Figure 5-33) that secure the pulley to the bushing. NOTE: When removing the screws in the cylinder assembly drive pulley, you can prevent the cylinder drive shaft from turning by inserting a 4-foot long board down through the shredder hopper and behind one of the blade/spacer rows on the cylinder assembly.

5. Thread the two screws into the smaller, *threaded* holes in the face of the bushing. Finger-tighten the screws until they contact the wall of the pulley. Then, using the wrench, *alternately and evenly* tighten the two screws, turning them no more than 1/2 turn at a time. The screws will slowly push the pulley away from the bushing until the two parts are separated. Slide the pulley and bushing off the shaft.

IMPORTANT: Do not use excessive or uneven pressure on the screws. Doing so may damage the bushing.

6. Remove the two screws from the threaded holes in the bushing or pulley.

7. Wipe any dirt and grime from the pulley, bushing and shaft with a clean cloth. Inspect the pulley and bushing and do not reuse if damaged or excessively worn (call the factory if you are unsure about the condition of the parts).

IMPORTANT: Do not use lubricants on the pulley, bushing, screws or shaft. The use of lubricants can cause the bushing to break.

Pulley Replacement:

IMPORTANT: The engine drive pulley must be installed on the engine crankshaft before the cylinder assembly drive pulley is replaced. To replace the engine drive pulley, follow Steps 1 through 4. To replace the cylinder assembly drive pulley, follow Steps 5 through 7.

1. Assemble the bushing and pulley by sliding the pulley onto the shank of the bushing (the pulley will only fit in one direction due to its tapered bore). Align the large, *unthreaded* holes in the bushing with the holes in the pulley. Using your fingers only, thread the two hex heads screws into the pulley until the screw heads are seated flush against the bushing.

2. Slide the bushing/pulley assembly onto the engine crankshaft, making sure that the hub of the bushing is facing toward the engine.

3. With an assistant helping you, reinstall the engine using the four screws and flanged locknuts removed earlier. Tighten the screws and nuts securely.

IMPORTANT: It is critical that the pulleys be properly aligned. Misalignment can cause premature belt wear or belt breakage.

4. The belt groove in the engine drive pulley must be aligned with the belt groove in the idler pulley. To align the grooves:

- Move the Clutch Lever down to the ENGAGED position.
- Slide the bushing/pulley assembly in or out until the pulley groove is centered over the groove in the idler pulley.
- Slide the bushing/pulley assembly 1/16" toward the chipper/shredder main frame. This 1/16" offset will be taken up when the screws that secure the pulley to the bushing are tightened in the next step.

- d. To prevent the engine crankshaft from turning when you tighten the pulley mounting screws, insert a board between the engine pulley and the inside edge of the engine mounting bracket, and pull the board tightly against the pulley. Then, using a 7/16 in. wrench, *alternately and evenly* tighten the two screws until they are secure. (If using a torque wrench, tighten screws to 90-in. lbs.)

IMPORTANT: Do not use excessive or uneven pressure on the screws. Doing so may damage the bushing or pulley.

- e. Check that the engine pulley and idler pulley grooves are properly aligned and adjust if needed. When finished, move the Clutch Lever up to the DISENGAGED position.
- f. If the cylinder assembly pulley was not removed, check that it is properly aligned with the engine drive pulley. Do this by placing a straightedge against the coinciding walls of the two pulleys. See Figure 5-35. If the cylinder assembly pulley is correctly aligned, proceed to Step g. If the cylinder assembly pulley is not aligned, reposition it by following Steps 5 through 7.
- g. With both pulleys properly installed, reinstall the drive belt and the belt guard (refer to Page 29). On electric start models, reinstall the battery (refer to Page 40).

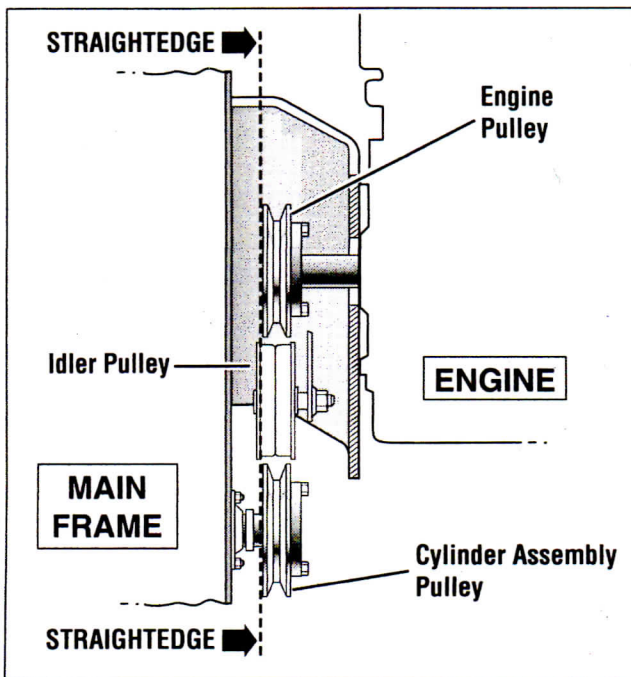

(Figure 5-35) To check alignment of pulleys, place a straightedge against outer walls.

5. To replace the cylinder assembly pulley, first assemble the pulley and its bushing by following Step 1 of these pulley replacement instructions. Then proceed to Step 6.

6. Slide the bushing/pulley assembly onto the drive shaft, making sure that the hub of the bushing is facing toward the engine.

IMPORTANT: It is critical that the pulleys be properly aligned. Misalignment can cause premature belt wear or belt breakage.

7. The cylinder assembly pulley must be aligned with the engine drive pulley. To align the pulleys:

- a. Place a straightedge against a wall of the engine drive pulley and slide the cylinder assembly bushing/pulley in or out until the coinciding wall of the pulley is aligned with the straightedge. See Figure 5-35. Then, slide the bushing/pulley assembly 1/16" toward the chipper/shredder main frame. This 1/16" offset will be taken up when the screws that secure the pulley to the bushing are tightened in the next step.

- b. To prevent the cylinder drive shaft from turning when you tighten the pulley mounting screws, insert a broom handle or long board down through the shredder hopper, wedging it behind one of the blade/spacer rows on the cylinder assembly. Using a 7/16 in. wrench, *alternately and evenly* tighten the two screws until they are secure. (If using a torque wrench, tighten screws to 90-in. lbs.) Remove the broom handle or board from the shredder hopper.

IMPORTANT: Do not use excessive or uneven pressure on the screws. Doing so may damage the bushing or pulley.

- c. Using the straightedge, check once more that the engine pulley and cylinder assembly pulley are properly aligned and adjust if needed.
- d. With both pulleys properly installed, reinstall the drive belt and the belt guard (refer to Page 29). On electric start models, reinstall the battery (refer to Page 40).

Battery Care and Maintenance

The following guidelines will help to protect the battery while it is in service during seasonal use and during extended periods of storage.

WARNING

CAREFULLY FOLLOW ALL SAFETY RULES WHEN WORKING WITH OR NEAR THE BATTERY. FAILURE TO FOLLOW SAFETY RULES CAN RESULT IN PERSONAL INJURY OR PROPERTY DAMAGE FROM HAZARDS SUCH AS EXPLOSION OF BATTERY GASES, ACID BURNS OR ELECTRICAL BURNS.

WARNING

INSUFFICIENT FLUID IN BATTERY CELLS COULD LEAD TO A BATTERY EXPLOSION RESULTING IN SEVERE PERSONAL INJURY. CHECK FLUID LEVEL REGULARLY AND ADD WATER WHEN BELOW THE "UPPER" LINE MARKED ON SIDE OF BATTERY CASE.

Care in Service

1. Monthly, or every 10 operating hours (whichever occurs first), check the level of the battery electrolyte. With the battery level, the electrolyte should be at the "Upper Level" line marked on the battery case. Use distilled or demineralized water to refill each battery cell to the proper level. NEVER USE BATTERY ACID TO REFILL THE BATTERY! Securely reinstall the battery caps and clean up any spills with a baking soda and water solution. Operate engine outdoors for 20 minutes to help recharge and recirculate the electrolyte solution. For safety, DO NOT leave the chipper/shredder unattended while the engine is running.
2. Keep the battery clean. Remove corrosion from battery posts or cable terminals with a baking soda and water solution (tighten battery caps securely before cleaning battery.) AVOID CONTACT WITH THE CORROSIVE MATERIAL (WHICH IS ACID OXIDATION) ON YOUR SKIN OR IN YOUR EYES. Clean any remaining solution off the battery. Use sandpaper or steel wool to thoroughly clean the posts and terminals. Then, apply petroleum jelly or silicone grease to prevent new corrosion from forming.
3. Periodically check the entire electrical system for loose or dirty connections.
4. Periodically check the battery clamp for tightness. Do not overtighten the clamp as doing so could damage the battery case.
5. Periodically check the battery vent tube. It must not be crimped or pinched anywhere along its length.

Care In Storage

Charge the battery before and after extended periods of storage.

WARNING

BATTERIES PRODUCE EXPLOSIVE GASES WHICH CAN CAUSE SEVERE PERSONAL INJURY.

WHEN CHARGING OR USING BATTERY, DO SO IN A WELL-VENTILATED AREA. KEEP SPARKS, FLAME AND SMOKERS' MATERIALS FAR AWAY. DO NOT LEAVE BATTERY UNATTENDED WHILE CHARGING. CAREFULLY FOLLOW ALL CHARGING INSTRUCTIONS AND SAFETY RULES PROVIDED BY BATTERY AND RECHARGER EQUIPMENT MANUFACTURERS.

1. Remove battery from machine and place it on a level surface.
2. The battery should be clean. If battery is cold, allow it to warm to between 60° F-80° F.
3. Remove all six filler caps. Leave caps off during filling and charging procedures.
4. Check electrolyte levels. If low, fill to "Upper Level" line on battery case with distilled or demineralized water (DO NOT ADD BATTERY ACID). Avoid overfilling.
5. Charge battery completely. Refer to Section 2 for detailed battery charging instructions. When battery is fully charged, turn off charger and then disconnect charging equipment.
6. Check electrolyte levels. If low, add distilled or demineralized water (DO NOT ADD BATTERY ACID) until level reaches "Upper Level" line. After refilling, charge battery again until cells are gassing freely.
7. Replace caps on battery and wash off any spilled electrolyte with a baking soda and water solution.
8. Store battery in a cool, dry location. Avoid freezing temperatures. The ideal storage temperature is 50° F.

Battery Removal and Replacement

Follow these steps when removing or installing the battery.

1. Stop the engine and disconnect the spark plug wire. Remove the ignition key.
2. Disconnect the negative (-) cable from the ground location on the bolt through the axle bracket. Bend the cable safely away from any metal parts.
3. Disconnect the negative cable (-) from the negative battery post and remove the cable.
4. Disconnect the positive (+) cable from the positive battery post (leave the other end of the cable connected to the solenoid). Cover the loose end of the cable with the rubber insulating boot.
5. Remove the battery hold-down clamp and then remove the battery.
6. When installing the battery, replace the cables in the reverse order from which they were disconnected.

SPECIFICATIONS

	8HP Super Tomahawk Chipper/Shredder	5HP Super Tomahawk Chipper/Shredder	4HP Tomahawk Chipper/Shredder
Chipping/Shredding Capability:	1"-to-3" diameter material in chipper; up to 1" diameter material in shredder	Same as 8HP Model	3/4"-to-2" diameter material in chipper; up to 3/4" diameter in shredder
Frame Construction:	Heavy-gauge steel; with 10" wide steel shredding chamber	Same as 8HP Model	Same as 8HP Model; but 8" wide mainframe
Shredder Flail Cutter Blades:	Sixteen 3/16" thick, hardened steel blades (4 cutting edges per blade)	Same as 8HP Model	Twelve 3/16" thick, hardened steel blades (4 cutting edges per blade)
Chipper Blade:	Hardened steel blade (revolves @ 3600RPM)	Same as 8HP Model	Same as 8HP Model
Chipper/Flywheel:	13" diameter steel flywheel	Same as 8HP Model	Same as 8HP Model
Overall Measurements:			
Length —	40" (with chipper chute attached)	Same as 8HP Model	30" (with chipper chute attached)
Width —	29" (discharge tunnel to wheel)	Same as 8HP Model	Same as 8HP Model
Height —	45" (to top of handlebar)	Same as 8HP Model	Same as 8HP Model
Tires:	10" x 4", semi-pneumatic	Same as 8HP Model	Same as 8HP Model

ENGINES

	8HP Briggs & Stratton	5HP Tecumseh	4HP Tecumseh
Manufacturer & General Specs:	Briggs & Stratton, Model 190412 (manual), Model 190417 (electric) four-cycle single-cylinder, air-cooled. Horizontal crankshaft. Manual choke. Industrial/Commercial (I/C) version of this engine is Model 195437.	Tecumseh, Model H50 (manual and electric) four-cycle single-cylinder, air-cooled. Horizontal crankshaft. Manual choke.	Tecumseh, Model HS40 (manual) four-cycle single-cylinder, air-cooled. Horizontal crankshaft. Manual choke.
Horsepower:	8HP	5HP	4HP
Motor Oil Requirements:	Summer — SAE 30 (substitutes: SAE 10W30 or SAE 10W40). Winter — SAE 5W20 or SAE 5W30. Use Service Classification SG or SF.	Summer — SAE 30 (substitute: SAE 10W30). Winter — SAE 5W30 (substitute: SAE 10W). Use Service Classification SG or SF.	Summer — SAE 30 (substitute: SAE 10W30). Winter — SAE 5W30 (substitute: SAE 10W). Use Service Classification SG or SF.
Motor Oil Quantity:	39 ounces approx.	19 ounces approx.	21 ounces approx.
Fuel Tank Capacity:	4 quarts	4 quarts	4 quarts
Fuel Recommendation:	Use Unleaded Regular automotive gasoline. If not available, Leaded Regular may be used.	Use Unleaded Regular automotive gasoline. Leaded Regular is an acceptable substitute.	Same as 5HP Model.
Spark Plug:	Champion RCJ-8 or its equivalent. Spark plug gap — .030".	Champion J-8 or its equivalent. Spark plug gap — .030". Canadian Owners use Champion RJ-17LM.	Champion J8C or J-8, or its equivalent. Spark plug gap — .030". Canadian Owners use Champion RJ-17LM.
Ignition System:	Maintenance-free Magnetron™ solid-state system (no points or condenser).	Maintenance-free solid-state system (no points or condenser).	Maintenance-free solid-state system (no points or condenser).

(See your engine manufacturer literature for further specifications and details.)