

GRAVELLY OPERATOR'S CLARKE-GRAVELLY CORPORATION A Studebaker-Worthington Company **MANUAL**

NAME: ROTARY CULTIVATOR

PART NUMBER(S): 22162

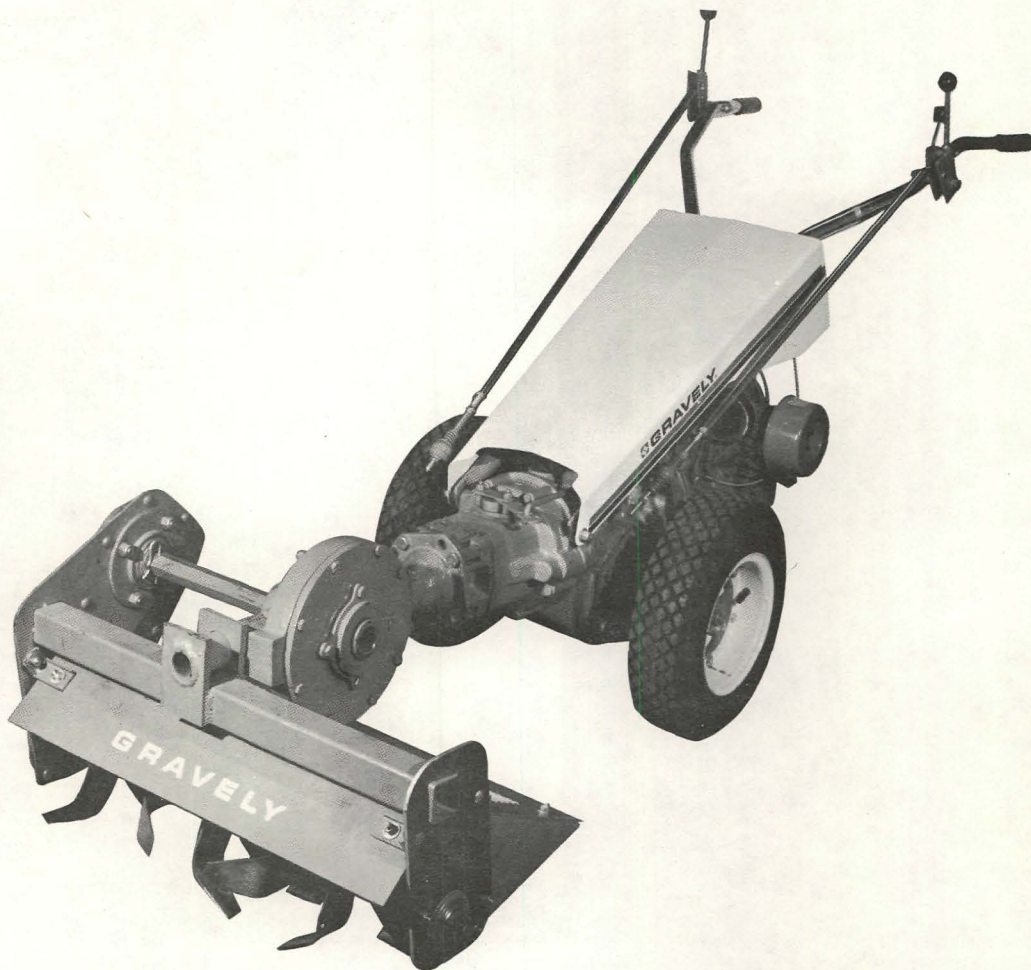

The Rotary Cultivator is designed and built to be used with the Gravelly two wheel tractors.

To attach the Rotary Plow to a Gravelly tractor manufactured before serial number 290130 an attachment adapter kit is required. See your Gravelly Dealer for further information.

The Operator's Manual includes safety operating practices, illustrated parts list, operation and maintenance.

ROTARY CULTIVATOR LESS DRIVE

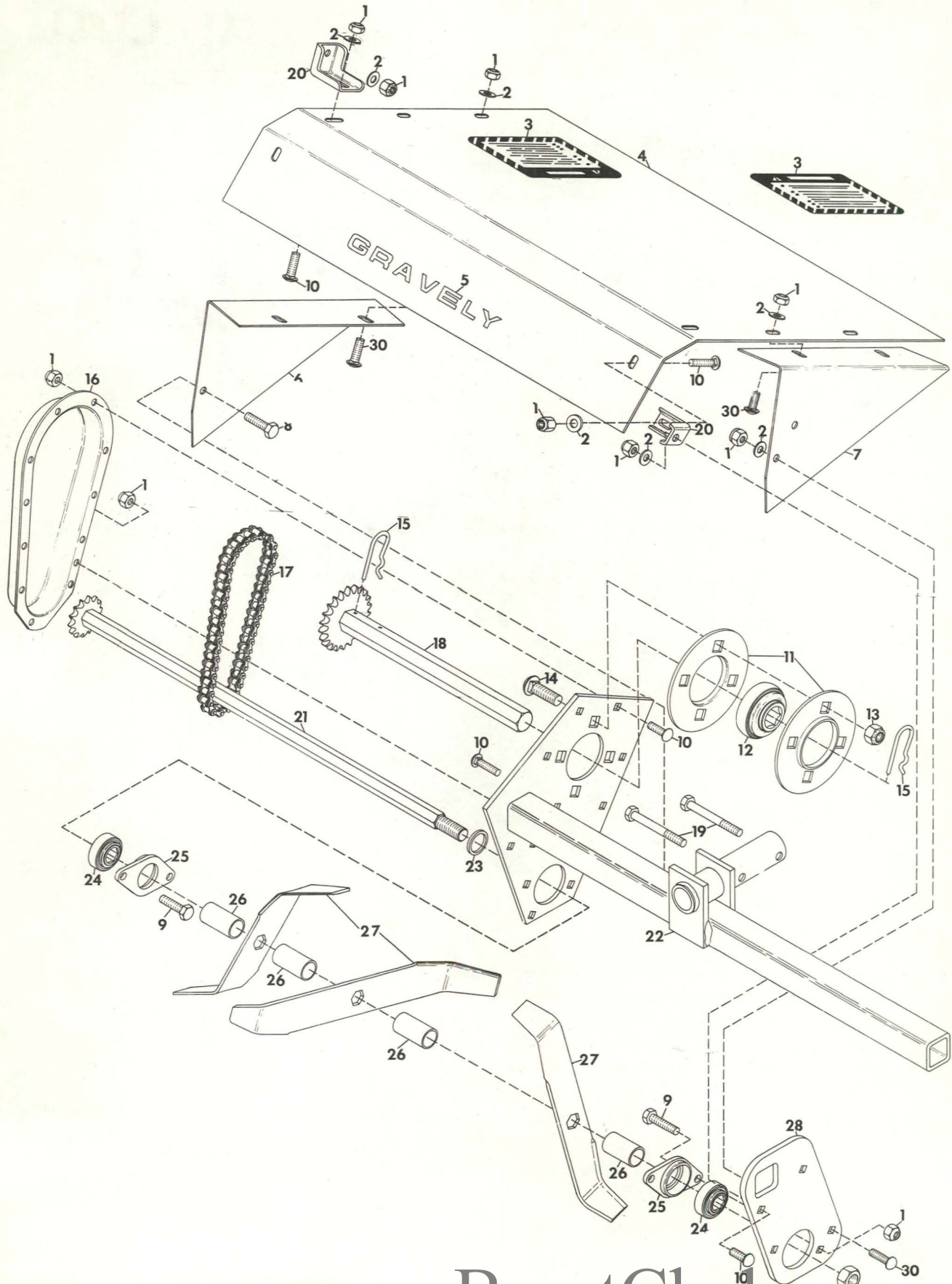

ROTARY CULTIVATOR LESS DRIVE

<u>ITEM NO.</u>	<u>PART NO.</u>	<u>QTY.</u>	<u>DESCRIPTION</u>
1	419455	27	Nut, Lock; 5/16-18 Washer Insert Hex
2	120393	12	Washer, Flat; .344 x .688 x .065
3	19479	2	Decal, Caution
4	22212	1	Shield, Dirt
5	19365	1	Decal, Gravely White Vinyl
6	22201	1	Shield, Side R. H.
7	22211	1	Shield, Side L. H.
8	180078	2	Bolt, Hex; 5/16-18 x 7/8
9	180081	4	Bolt, Hex; 5/16-18 x 1.25
10	126353	16	Bolt, 5/16-18 x 7/8 RD HD SQ NK
11	22186	2	Flangette, Pressed Steel
12	22185	1	Bearing, Hex Bore
13	435507	4	Nut, Lock; 1/2-13 Washer Insert
14	126485	4	Bolt, 1/2-13 x 1-1/4 RD HD SQ NK
15	13466	2	Pin, Depth Adjusting
16	22200	1	Cover, Sprocket
17	22198	1	Chain, Roller .625 Pitch
18	22187	1	Weldment, Drive Sprocket
19	180188	2	Bolt, Hex; 1/2-13 x 2-3/4
20	22199	4	Bracket, Shield
21	22194	1	Weldment, Tine Shaft
22	22178	1	Weldment, Cultivator Frame
23	22197	1	Spacer, Sprocket; 1.185 x 1.37 x .202
24	22193	2	Bearing, Hex Bore 1 Inch
25	22192	2	Housing, Bearing
26	22202	9	Spacer, Tine
27	22203	8	Tine, Hoe
28	22205	1	Plate, Support
29	426899	1	Nut, Jam 1-8 Hex
30	126216	5	Bolt, 5/16-18 x 3/4 RD HD SQ NK

SAFETY OPERATING PRACTICES

Proper maintenance is important to the safe operation of all equipment. This attachment is no exception. The operation and maintenance suggestions contained in this manual are effective methods for operating and servicing this attachment.

Improper use of this attachment can result in damage to the equipment or severe personal injury. Persons operating and maintaining this equipment must read these manuals completely and be required to practice these safety precautions and pay attention to the job being done.

It is important to understand that the warnings in this manual are not all inclusive. It is not possible for Gravelly to know, evaluate and advise operators and servicing personnel of all the possible hazardous consequences of operating and servicing this attachment. Accordingly, any person operating or servicing this attachment in a manner not expressly recommended by Gravelly must first satisfy themselves that their safety the safety of others and equipment safety are not jeopardized by the method of operation or service electec

TRAINING

1. Read the tractor and cultivator operator's manuals carefully before operating or servicing. Be thoroughly familiar with the equipment. Know how to stop the cultivator tines and how to operate the tractor controls quickly.
2. Never allow children to operate the equipment. Never allow adults to operate the equipment without proper instructions.
3. Keep area of operation clear of all persons. Small children and pets are especially difficult to see. Never allow anyone in front of the equipment.
5. Do not wear loose fitting clothing or accessories that might get caught in moving parts or on the controls. Keep hands, feet, hair, clothing, etc., away from moving parts. Always wear substantial footwear. Do not wear open sandals or canvas shoes.
6. Before leaving the operator's position, STOP the engine and disengage the cultivator drive by placing the PTO lever in the OFF position, remove key.

PREPARATION

1. Thoroughly inspect the area where the equipment is to be used and remove all large stones, glass, metal, bones, sticks, wires, and the like. Stay alert for holes and hidden hazards.
2. Disengage all clutches before starting the engine. This is done by placing the PTO lever in the OFF position and the forward-reverse in the mid or neutral position.
3. Never make any adjustment to the cultivator while engine is running.
4. Do not put hands or feet near rotating parts.

OPERATION

1. Never attempt to make any adjustments while engine is running.
2. Never operate the equipment without good visibility and light.
3. Handle fuel with care, it is highly flammable.
 - (a) Do not smoke while handling fuel.
 - (b) Use approved fuel container.
 - (c) Never add fuel to a running engine or hot engine.
 - (d) Fill fuel tank outdoors with extreme care. Never fill fuel tank indoors.

- (e) Replace gasoline cap securely and wipe up spilled fuel.
 - (f) Always fill electric start tractors with tractor hood in the closed position.
4. Be sure the path is clear of people, pets, and obstructions especially when backing.
 5. Do not operate equipment except from proper operator's position.
 6. Keep safety devices and shields in place at all times.
 7. Persons must never accompany the operator.
 8. Always disengage the cultivator drive by placing the PTO lever in the OFF position when the attachment is not in use, when crossing pavement or barriers and before leaving operator's seat or position.
 9. Use extreme caution when operating on slopes. Reduce speed on all slopes and sharp turns. Exercise extreme caution when changing direction on slopes.
 10. DO NOT cultivate excessively steep slopes.
 11. If an object is struck, STOP the engine and put the PTO in the OFF position before inspecting for damage. Any damage must be repaired before restarting the equipment.
 12. Before cleaning, repairing, or inspecting, make certain the tines and all moving parts have stopped. Remove the key and disconnect the sparkplug wire to prevent accidental starting.
 13. If the cultivator should start to vibrate abnormally, immediately STOP the engine, disengage the PTO, and check for cause. Abnormal vibration is generally a warning of trouble. If unable to locate cause, obtain qualified service assistance.
 14. Do not run engine indoors, except when starting engine and for transporting equipment in or out of building. Open outside doors to insure proper ventilation.
 15. Always operate the tractor in the lower gears when on slippery surfaces.
 16. Always be sure of your footing; keep a firm hold on the handles and walk, never run.

MAINTENANCE AND STORAGE

1. Always maintain the equipment as specified in the product literature. Keep it in good repair and inspect regularly.
2. Inspect the drive system for wear and damage regularly.

The rotary cultivator is factory assembled. The rotary cultivator uses either the rotary plow drive or plow/cultivator drive. One of these drives will have to be installed on the rotary cultivator.

ATTACHING THE DRIVE TO THE ROTARY CULTIVATOR

1. Position the drive on its side with the top of the drive towards the hex drive shaft and slide the drive onto the hex shaft until the drive is snug against the frame weldment. The top of the drive has the grease fitting.
2. Secure the drive to the frame weldment with the two bolts. See fig. 1.

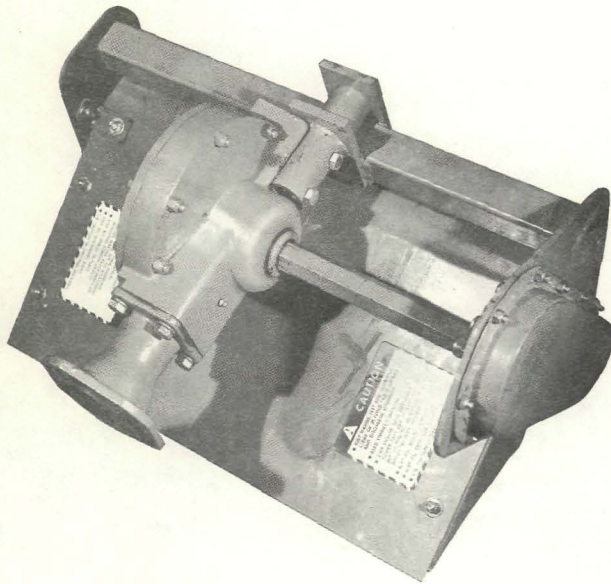

Fig. 1

PREPARING THE ROTARY PLOW DRIVE FOR ATTACHING TO THE ROTARY CULTIVATOR

1. Remove the dirt shield from the plow drive by removing the bolts holding the adjusting straps to the drive. Replace the bolts in the drive and tighten securely.
2. Remove the depth adjusting pin from the rotor shaft and remove the shaft and spade assembly from the drive.
3. Remove the two bolts securing the depth wheel assembly to the drive and remove the assembly. See fig. 2.

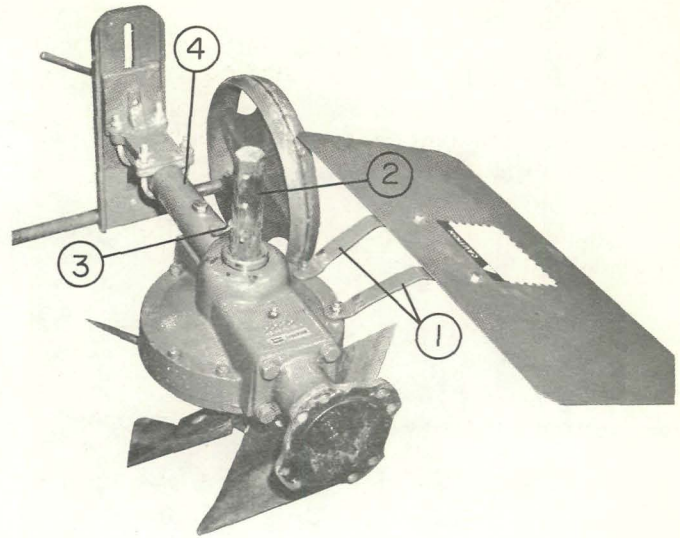

Fig. 2

- 1 — Adjusting Straps
- 2 — Rotor Shaft
- 3 — Depth Adjusting Pin
- 4 — Depth Wheel Assembly

4. The rotary plow drive will appear as shown in fig. 3 when properly prepared for attaching to the rotary cultivator.

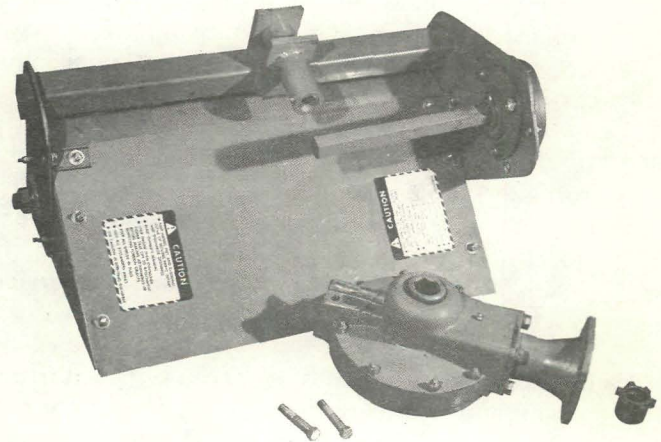

Fig. 3

5. Attach the plow drive to the rotary cultivator as described in steps 1 and 2.

MOUNTING THE ROTARY CULTIVATOR TO THE TRACTOR

1. Slide the attachment dog onto the splined PTO shaft of the tractor. See fig. 4.

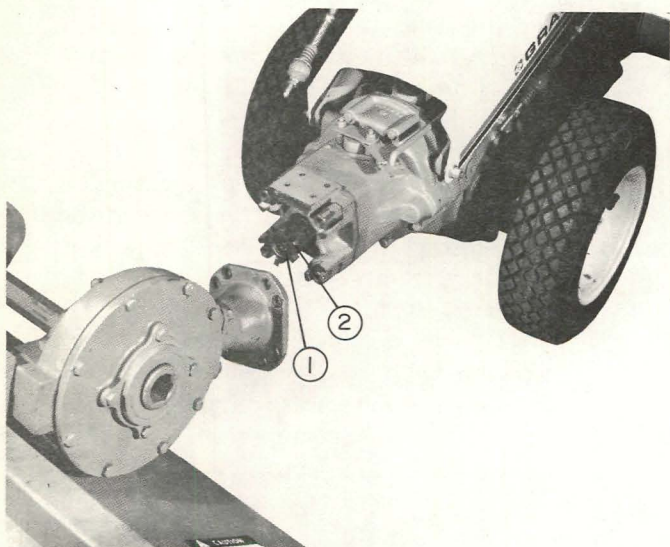

Fig. 4

- 1 — Splined PTO Shaft
- 2 — Attachment Dog

2. Bolt the cultivator to the attachment adapter of the tractor with the four attachment bolts. See fig. 5.

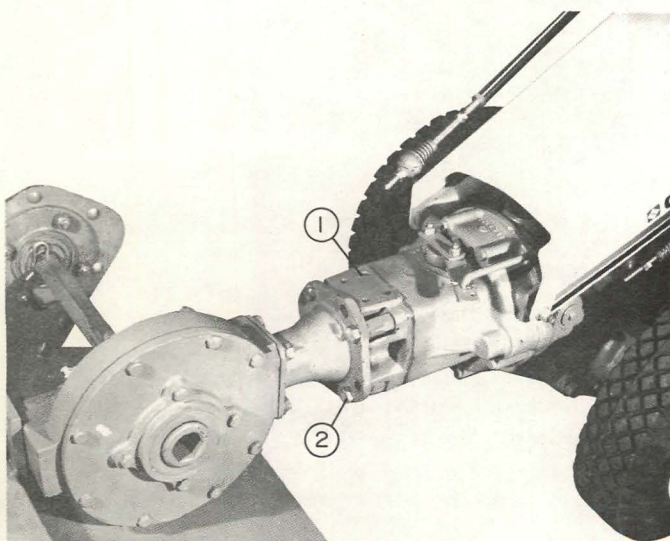

Fig. 5

- 1 — Attachment Adapter
- 2 — Attachment Bolt

OPERATION

Read the tractor Operator's Manual and become familiar with its operation. Know how to operate the controls and their function.

1. With all the tractor controls in neutral, start the tractor engine and allow a few minutes for the engine to warm up.
2. Put the Swiftmatic gear in "LOW" if so equipped.
3. Move the throttle lever up to about half throttle.
4. Engage the PTO.
5. Move the throttle lever down to "FAST".
6. Put the HI/LO range in "LO".
7. Engage the direction control lever on the tractor in the forward position.
8. Operate the tractor and cultivator in the open without obstructions until you become familiar with the operation of the tractor and cultivator.

REMOVING THE ROTARY CULTIVATOR FROM THE TRACTOR

1. Remove the four attachment bolts securing the rotary cultivator to the attachment adapter of the tractor and remove the rotary cultivator. See fig. 4.
2. Remove the attachment dog from the splined PTO shaft of the tractor and store with cultivator.
3. If the rotary plow is to be used, reverse steps 1-5 as described in Preparing The Rotary Plow Drive For Attaching To The Rotary Cultivator.

MAINTENANCE

1. Lubricate the cultivator gear drive with a grease gun through the grease fitting on top of the drive every 40 operating hours with general purpose grease.
2. Check all nuts, bolts and other fasteners to insure tightness. Tighten if necessary and replace any that are missing.
3. Check the hoe tines for wear. Worn hoe tines will reduce the tilling quality and affect the operation of the rotary cultivator. Replace worn or damaged hoe tines as described in Hoe Tine Replacement.

NOTE: Before removing the hoe tines, note the staggered position of the tines on the shaft.

3. Remove the hoe tines and spacers from the tine shaft weldment. Gravely recommends that all the tines be replaced.
4. There are 9 spacers and 8 hoe tines. When installing the tines, stagger the position of the tines around the shaft by moving the tine one position more on the shaft than the previous tine installed.
5. Slide a spacer, tine, spacer, tine, spacer, etc. on the shaft. Make sure the cutting edge of the tine faces the direction of the shaft rotation. The shaft rotates counter-clockwise as viewed from the hoe tine installation side. See fig. 7.
6. Replace the support plate and secure with the bolts, washers and nuts removed in step 2. Replace the nut on the tine shaft weldment and torque the nut to 125 ft. lbs. (169 Nm).

HOE TINE REPLACEMENT

1. Remove the nut from the tine shaft weldment. See fig. 6.

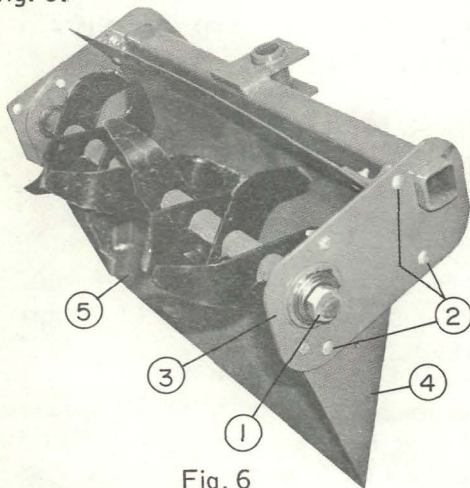

Fig. 6

- 1 — Tine Shaft Nut
- 2 — Bolts to be Removed
- 3 — Support Plate
- 4 — Side Shield
- 5 — Dirt Shield

2. Remove the three nuts and bolts securing the support plate to the side shield and dirt shield and remove the support plate. See fig. 6.

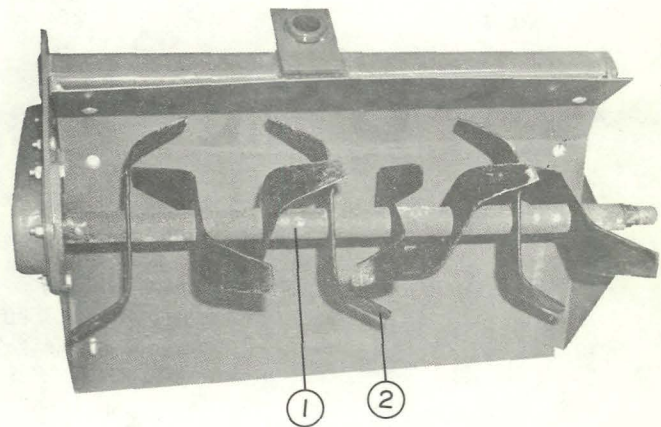

Fig. 7

- 1 — Spacer
- 2 — Tine

OFF SEASON STORAGE

1. Clean the unit and apply a light coat of oil to prevent rust.
2. Check all bolts, nuts and other fasteners for tightness and replace any that are missing.
3. Lubricate the gear drive.
4. Check for worn or damaged tines and replace if necessary.

GRAVELY.

ATTACHMENT LIMITED WARRANTY

This Limited Warranty is issued by Clarke-Gravely Corporation, Gravely Division, and consists of the following terms:

1. Only the original purchaser of new Gravely manufactured attachments is covered by this Warranty.
2. This Warranty covers repair or replacement of parts manufactured by Gravely which are defective in material or workmanship. Gravely will pay for parts and labor only.
3. The Warranty starts the date of purchase and lasts for NINETY (90) DAYS for attachments used in Rooper applications, and TWELVE (12) MONTHS for products used in all other applications.
4. Some components of Gravely attachments are not covered by the Gravely Warranty. These components are covered by the original manufacturer's warranty. They are:
 - (a) Tires - Goodyear, Goodrich, Armstrong, General and Firestone
5. To obtain warranty service on Gravely attachments including components not manufactured by Gravely, use this procedure:
 - (a) Notify the Gravely dealer from whom you purchased the attachment.
 - (b) If you have moved and it is not convenient to notify the selling dealer, notify the nearest Gravely dealer. You should supply this dealer with a copy of the bill of sale as proof of the date of purchase.
 - (c) Make arrangements to have the attachment delivered to the dealer (refer to paragraph 6(a) below).
 - (d) If you have any questions concerning the Gravely Warranty, they should be referred to:

Gravely
Clarke-Gravely Corporation
A Studebaker-Worthington Company
One Gravely Lane
Clemmons, N. C. 27012
Attn: Manager of Customer Services
 - (e) Warranty service on Gravely attachments must be performed by an authorized Gravely dealer or Gravely factory branch.

6. This Warranty does not cover the following:
 - (a) Transportation between owner's home or place of business and the dealership. If the dealer provides the transportation of the attachment, he will charge the owner his usual rate for such service.
 - (b) Normal maintenance services and normal replacement of items such as belts lubricants, mower, plow or cultivator blades.
7. GRAVELY MAKES NO OTHER EXPRESS WARRANTIES. ANY IMPLIED WARRANTIES, INCLUDING WARRANTIES AS TO MERCHANTABILITY OR FITNESS FOR A PARTICULAR PURPOSE, ARE LIMITED IN DURATION TO THE PERIOD SET OUT IN PARAGRAPH 3 ABOVE. SOME STATES DO NOT ALLOW LIMITATIONS ON HOW LONG AN IMPLIED WARRANTY LASTS, SO THE ABOVE STATEMENT MAY NOT APPLY TO YOU.
8. GRAVELY SHALL HAVE NO RESPONSIBILITY FOR INCIDENTAL OR CONSEQUENTIAL DAMAGES RESULTING FROM THE BREACH OF ANY WARRANTY, INCLUDING, BUT NOT LIMITED TO, INCONVENIENCE, RENTAL OR PURCHASE OF REPLACEMENT EQUIPMENT, LOSS OF PROFITS OR COMMERCIAL LOSS. SOME STATES DO NOT ALLOW THE EXCLUSION OR LIMITATION OF INCIDENTAL OR CONSEQUENTIAL DAMAGES, SO THE ABOVE LIMITATION OR EXCLUSION MAY NOT APPLY TO YOU.
9. This Warranty gives you specific legal rights, and you may have other rights which vary from state to state.
10. A Gravely registration card is supplied with each Gravely attachment. Please complete the card and return it to Gravely at the address listed on the card. The registration card will be used by Gravely for:
 - (a) Recording date of purchase.
 - (b) Notification of owners in compliance with the Consumer Product Safety Act, should any notification be necessary.The return of registration card is not required in order to take advantage of this Warranty.
11. This Warranty is not subject to change or modification by anyone, including Gravely dealers and no Gravely dealer is authorized to make any representations or promises on Gravely's behalf.

