

GRAVELY

CLARKE-GRAVELY CORPORATION
A Studebaker-Worthington Company

ILLUSTRATED PARTS LIST

NAME: LIFTABLE REAR HITCH

PART NUMBER(S): 24487

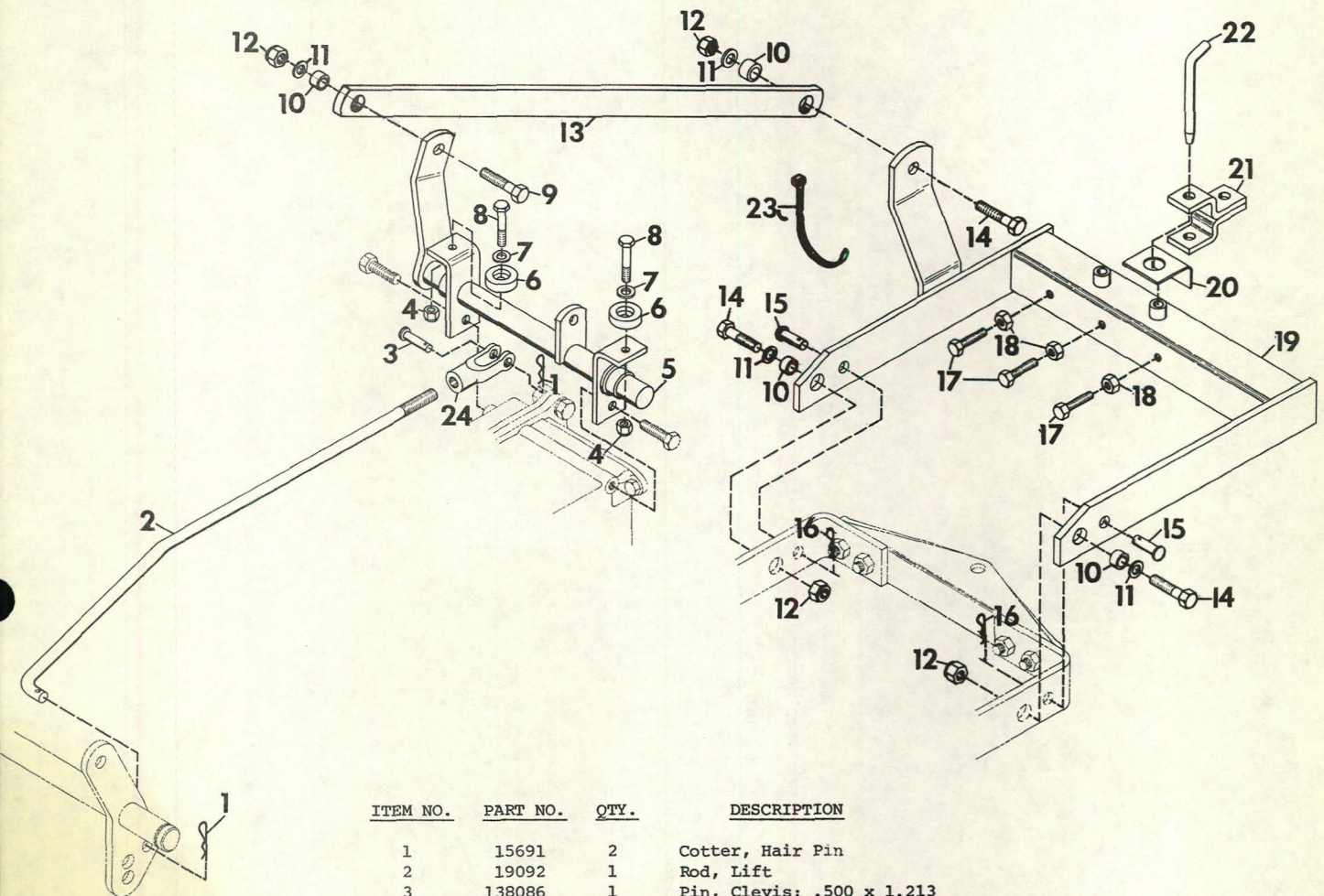

ITEM NO.	PART NO.	QTY.	DESCRIPTION
1	15691	2	Cotter, Hair Pin
2	19092	1	Rod, Lift
3	138086	1	Pin, Clevis; .500 x 1.213
4	419454	2	Nut, Lock; 1/4-20 Washer Insert
5	24375	1	Weldment, Cross Shaft
6	24357	2	Bumper, Seat
7	120386	2	Washer, Flat; 5/16 x 47/64 x .065
8	180024	2	Bolt, Hex; 1/4-20 x 1-1/4
9	180181	1	Bolt, Hex; 1/2-13 x 2
10	19260	4	Bushing, Pivot Casting
11	120396	4	Washer, Flat; .500 x 1.062 x .095
12	435507	4	Nut, Lock; 1/2-13 Washer Insert
13	24453	1	Strap, Rear Hitch
14	180179	3	Bolt, Hex; 1/2-13 x 1-3/4
15	20499	2	Pin, Clevis; 5/8 x 1.125
16	10405	2	Cotter, Hair Pin
17	14718	3	Bolt, Special; 3/8-16 x 3 Hex HD
18	451519	3	Nut, Jam; 3/8-16 Hex Heavy
19	24376	1	Weldment, Rear Hitch
20	14949	1	Pad
21	18866	1	Weldment, Rear Hitch
22	18864	1	Pin, Hitch
23	10629	2	Tie, Cable
24	19091	1	Yoke, Adjustable

To continue its program of quality and design improvement, the manufacturer reserves the right to change specifications, designs and prices without notice and incurring obligation.

Form No. 25170 (11-78)

Printed in U.S.A.

BrentChalmers.com