

GRAVELLY®

**500 SERIES
CONVERTIBLE
TRACTORS
ILLUSTRATIVE
PARTS LIST**

Form No. 21925 (11-76) Printed in U S A

BrentChalmers.com

This Illustrated Parts List covers the following models:

21039 - 520
21294 - 521
21038 - 522
21037 - 524
21031 - 526
21116 - 546
21250 - 564
21117 - 566

INDEX

Page

1-2	Basic Transmission
3-4	Standard Differential
5-6	Swiftamatic Differential
7-8	Frame Assembly (520,521 & 524 Tractors)
9-10	Frame Assembly (522,526,546,564 & 566 Tractors)
11-12	Controls (All 500 Series Tractors)
12	Wheel Assembly (All 500 Series Tractors)
13.	Remote Air Cleaner (564 Tractors Only)
14.	Engine and Exhaust System (All 500 Series Tractors)
15.	Electrical System (All 500 Series Tractors)
16.	Wiring Diagrams



A DIVISION OF CLARKE-GRAVELLY CORPORATION

ONE GRAVELLY LANE
CLEMMONS, NORTH CAROLINA 27012

BrentChalmers.com

BASIC TRANSMISSION

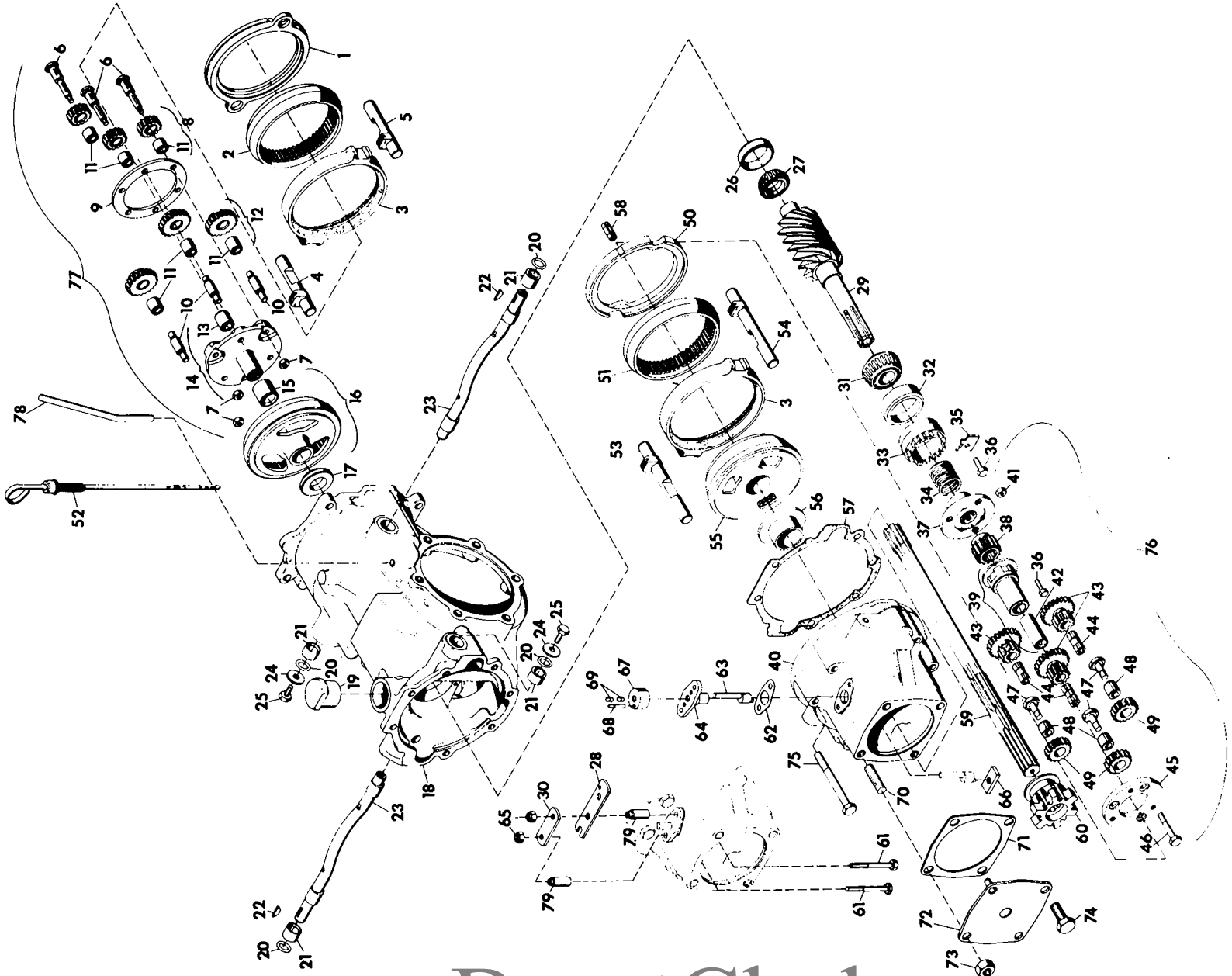

BASIC TRANSMISSION

ITEM NO.	PART NO.	DESCRIPTION
1.	11183P1	Spacer, Rear
2.	11182P1	Gear, Rear Ring
3.	12644A1	Assembly, Clutch Cup
4.	11185P1	Rod, Rear R. H. Clutch Slide
5.	11184P1	Rod, Rear L. H. Clutch Slide
6.	11181P1	Bolt, Orbit Gear
7.	11342P1	Nut, Lock; 5/16-18 L. H. Thread
8.	11179A1	Assembly, External Orbit Gear
9.	11178P1	Spacer, Pin
10.	11174P1	Pin, Hi-Lo Orbit Gear
11.	11177P1	Bushing; .501 x .627 x .495
12.	11175A1	Assembly, Internal Orbit Gear
13.	11172P1	Bushing, .737 x .877 x .682
14.	11171A1	Assembly, Planet Gear Carrier
15.	11169P1	Bushing; 1.250 x 1.502 x 1.312
16.	11168A1	Gear, Ring and Bushing
17.	12645P1	Plate, Rear Thrust
18.	10628P1	Chassis
19.	10617P1	Plug, Oil Filler
20.	10663P1	O-Ring; 3/4 x 1
21.	10618P1	Bushing; .750 x 1.002 x .625
22.	124545	Key, Woodruff; 1/8 x 5/8 Hard
23.	10625P1	Shaft, Actuating
24.	12694P1	Washer, Flat; .265 x 1.250 x .062
25.	180016	Bolt, Hex; 1/4-20 x 1/2
26.	10390P1	Cup, Roller Bearing
27.	10389P1	Cone, Roller Bearing
28.	12122P1	Arm, Shifter
29.	21242A1	Weldment, 6 Lead Worm (520, 522)
	21241A1	Weldment, 4 Lead Worm (521)
	21243A1	Weldment, 8 Lead Worm (524, 526, 546, 564 & 566)
30.	20822P1	Spacer, Strap
31.	12332P1	Cone, Roller Bearing
32.	12333P1	Cup, Roller Bearing
33.	12635P1	Nut, Bearing Adjustment
34.	12663P1	Spacer, Spring Pin Plate
35.	12648P1	Nut, Adjusting
36.	180018	Bolt, Hex; 1/4-20 x 5/8
37.	12633P1	Plate, Front Pin
38.	12637P1	Gear, Sun Pinion Spur
39.	14923A1	Assembly, Quill and Bushing
40.	12587P1	Casting, Advance
41.	120375	Nut, Hex; 1/4-20
42.	12662P1	Bushing; .875 x 1.000 x 2.000
43.	12639P1	Gear, Orbit Spur
44.	11630P1	Pin, Fwd-Rev Orbit Gear Bronze
45.	12655P1	Spacer, Front Pin
46.	12643P1	Bolt, Spacer (Right Hand)
47.	12658P1	Bolt, Reverse Idler
48.	12657P1	Bushing, Reverse Idler; .375 x .685 x .516
49.	12656P1	Gear, Reverse Idler Spur
50.	12636P1	Cup, Gear
51.	12632P1	Gear, Internal Spur
52.	10622A1	Assembly, Dip Stick
53.	12678P1	Rod, Clutch Slide R. H.
54.	12677P1	Rod, Clutch Slide L. H.
55.	12654P1	Cone, Reverse Gear
56.	14921A1	Assembly, Thrust Bushing
57.	12591P1	Gasket, Chassis Front
58.	13456P1	Pin, Roll
59.	11298P1	Shaft, Pinion
60.	12660P1	Dog, Attachment
61.	180089	Bolt, Hex; 5/16-18 x 2 1/4
62.	18318P1	Gasket, Shipper Shaft
63.	10686P1	Shaft, Shipper
64.	10687P1	Guide, Shipper Shaft
65.	9419455	Nut, Lock; 5/16-18 Washer Insert
66.	12601P1	Block, Trunnion
67.	10688P1	Body, Shipper Shaft
68.	12320P1	Dowel, Shifter Body
69.	102591	Screw, Set; 3/8-16 x 1/4 Hex Socket
70.	10619P1	Stud
71.	5056P1	Attachment, Gasket
72.	14908P1	Cover, Boss Attachment
73.	120238	Nut, Jam; 1/2-13
74.	180175	Bolt, Hex; 1/2-13 x 1 1/4
75.	180735	Bolt, Hex; 5/16-18 x 3 1/4
76.	14922A1	Assembly, Fwd-Rev Planet
77.	14615A1	Assembly, Hi-Lo Planetary
78.	10586P1	Guide, Dipstick
79.	12123P1	Spacer

STANDARD DIFFERENTIAL

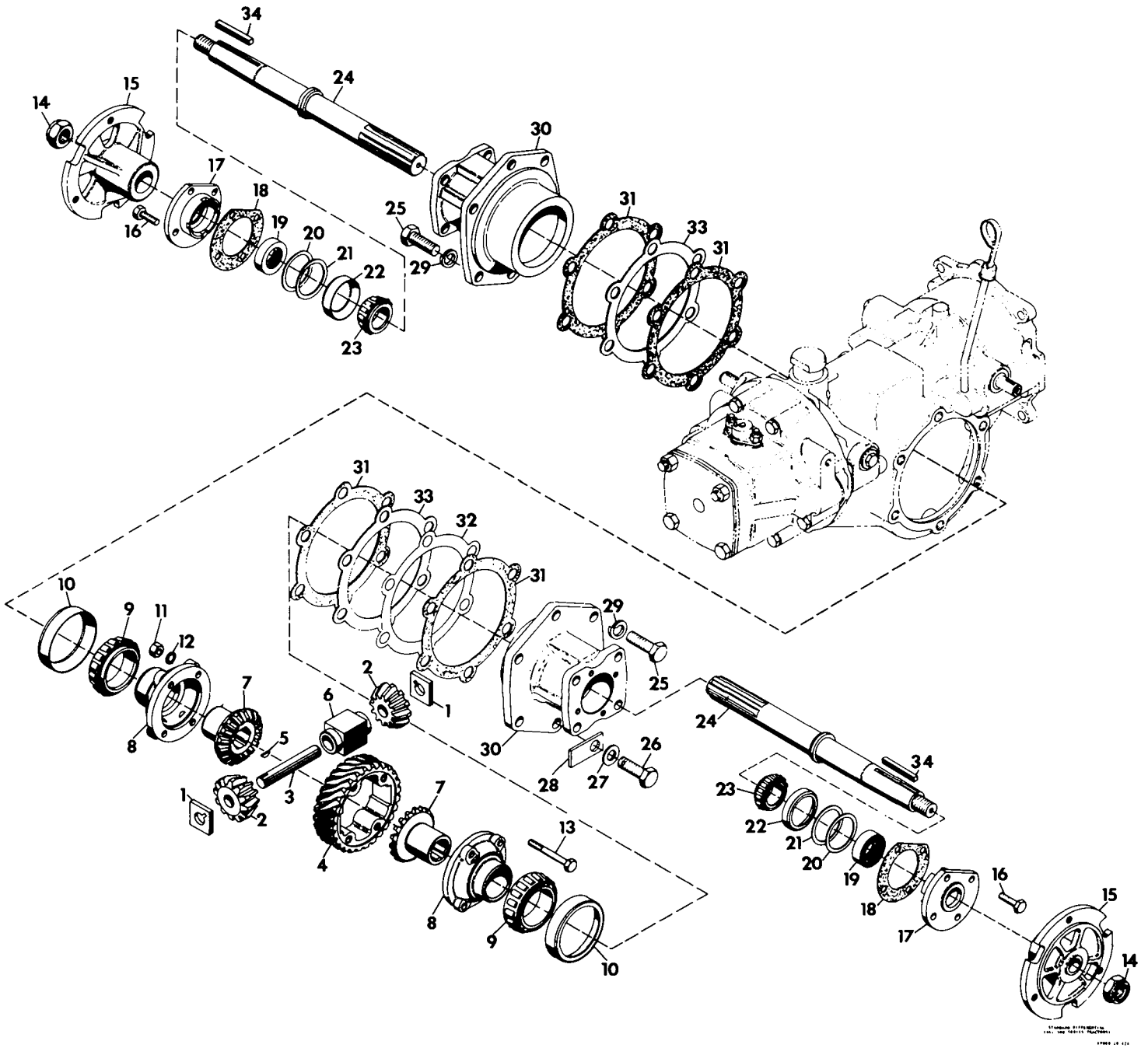

STANDARD DIFFERENTIAL

<u>ITEM NO.</u>	<u>PART NO.</u>	<u>DESCRIPTION</u>
1.	12667P1	Block, Drive
2.	12666P1	Gear, Spider Pinion Bevel
3.	12556P1	Pin, Spider Pinion
4.	13497P1	Gear, 4 Lead Worm (521)
	13498P1	Gear, 6 Lead Worm (520,522)
5.	271089	Key, Woodruff; 1/8 x 3/8 Hard
6.	12559P1	Block, Differential Thrust
7.	12555P1	Gear, Differential Bevel
8.	12129P1	Housing, Differential
9.	12131P1	Cone, Roller Bearing
10.	12130P1	Cup, Roller Bearing
11.	120368	Nut, Hex; 5/16-24
12.	138538	Washer, Lock; 5/16 Internal Tooth
13.	181623	Bolt, Hex; 5/16-24 x 2-3/4
14.	13412P1	Nut, Lock; 5/8-18 L. T.
15.	12671P1	Hub, Wheel
16.	180077	Bolt, Hex; 5/16-18 x 3/4
17.	10379P1	Cap, Bearing
18.	10384P1	Gasket, Bearing Cap
19.	12590P1	Seal, Oil; 1.000 x 1.503 x .500
20.	10383P1	Shim; .005
21.	10382P1	Shim; .020
22.	9245P1	Cup, Roller Bearing
23.	9246P1	Cone, Roller Bearing
24.	10377P1	Axle, Standard
25.	180173	Bolt, Hex; 1/2-13 x 1
26.	13624P1	Bolt, Hex; 1/2-13 x 1 Nylon Insert
27.	120396	Washer, Flat; 17/32 x 1 x 1/16 x .095
28.	12594P1	Washer, Oil Drain
29.	120384	Washer, Lock; 1/2 SP
30.	12128P1	Housing, Axle
31.	12597P1	Gasket, Axle Housing
32.	12595P1	Shim, Axle Housing; .005
33.	12596P1	Shim, Axle Housing; .020
34.	12672P1	Key, Hub

SWIFTAMATIC DIFFERENTIAL

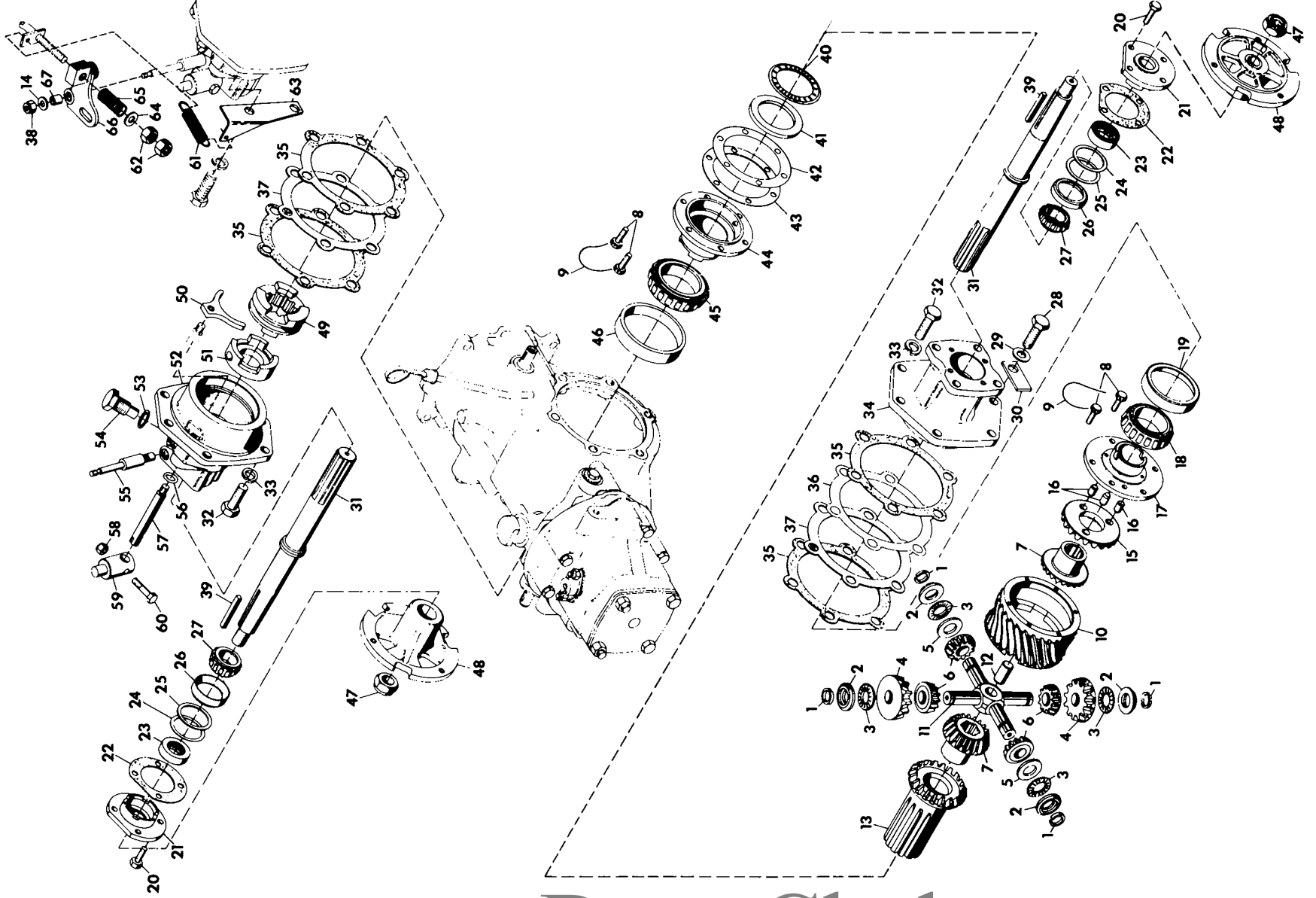

SWIFTAMATIC DIFFERENTIAL

<u>ITEM NO.</u>	<u>PART NO.</u>	<u>DESCRIPTION</u>
1.	15733P1	Ring, Retaining; .750 Shaft
2.	15734P1	Spacer; .765 x 1.245 x .200
3.	6741P1	Bearing, Needle Thrust; .752 x 1.240 x .078
4.	6702P1	Gear, Differential Shifting Bevel
5.	6742P1	Race, Bearing Thrust; .752 x 1.240 x .060
6.	6708P1	Gear, Spider Bevel
7.	6709P1	Gear, Differential Bevel
8.	18604P1	Bolt, Special; 5/16-18
9.	18605P1	Wire, Bolt
10.	15729P1	Gear, Worm 8 Start
11.	15732P1	Pin, Spider
12.	6711P1	Pin, Thrust
13.	6704P1	Gear, Hi-Lo Differential Shifting Bevel
14.	120393	Washer, Flat; 11/32 x 11/16 x .065
15.	6703P1	Gear, Pinned Bevel
16.	6714P1	Pin, Dowel; 3/8 x 1/2
17.	12126P1	Housing, Pinned
18.	12131P1	Cone, Roller Bearing
19.	12130P1	Cup, Roller Bearing
20.	180077	Bolt, Hex; 5/16-18 x 3/4
21.	10379P1	Cap, Bearing
22.	10384P1	Gasket, Bearing Cap
23.	12590P1	Seal, Oil; 1.000 x 1.503 x .500
24.	10383P1	Shim; .005
25.	10382P1	Shim; .020
26.	9245P1	Cup, Roller Bearing
27.	9246P1	Cone, Roller Bearing
28.	13624P1	Bolt, Hex; 1/2-13 x 1 Nylon Insert
29.	120396	Washer, Flat; 17/32 x 1 1/16 x .095
30.	12594P1	Washer, Oil Drain
31.	10377P1	Axle, Standard
32.	180173	Bolt, Hex; 1/2-13 x 1
33.	120384	Washer, Lock; 1/2 SP
34.	12128P1	Housing, Axle
35.	12597P1	Gasket, Axle Housing
36.	12595P1	Shim, Axle Housing; .005
37.	12596P1	Shim, Axle Housing; .020
38.	419455	Nut, Lock; 5/16-18 Washer Insert
39.	12672P1	Key, Hub
40.	6743P1	Bearing, Needle Thrust; 2.002 x 2.740 x .078
41.	6744P1	Race, Bearing Thrust; 2.002 x 2.740 x .092
42.	6739P1	Shim, Clutch Worm Gear; .005
43.	6740P1	Shim, Clutch Worm Gear; .020
44.	11148P1	Housing, Clutch
45.	12501P1	Cone, Roller Bearing
46.	12500P1	Cup, Roller Bearing
47.	13412P1	Nut, Lock; 5/8-18 L. T.
48.	12671P1	Hub, Wheel
49.	11632P1	Clutch, Shifting
50.	6719P1	Yoke, Shifting
51.	11156P1	Clutch, Stationary
52.	10381P1	Housing, 2-Speed Axle
53.	12707P1	Washer, Oil Strainer Nut
54.	6734P1	Bolt, Stationary Clutch
55.	10505P1	Pivot, Stationary
56.	6732P1	O-Ring; 7/16 x 5/8 x 3/32
57.	6721P1	Pin, Clutch Sliding
58.	419454	Nut, Lock; 1/4-20 Washer Insert
59.	6726P1	Pin, Shifter
60.	180024	Bolt, Hex; 1/4-20 x 1 1/4
61.	10681P1	Spring, Extension; 2.5 x .62 x 5.8 LB/in
62.	124925	Nut, Jam; 3/8-24
63.	10680P1	Bracket, 2-Speed Spring
64.	120394	Washer, Flat; 13/32 x 13/16 x .065
65.	10682P1	Spring, Compression; 2 x .720 x 15.5 LB/in
66.	6723P1	Arm, Shifter
67.	6724P1	Bushing, Nylon; .378 x .503 x .875

FRAME ASSEMBLY

(520, 521 & 524 TRACTORS)

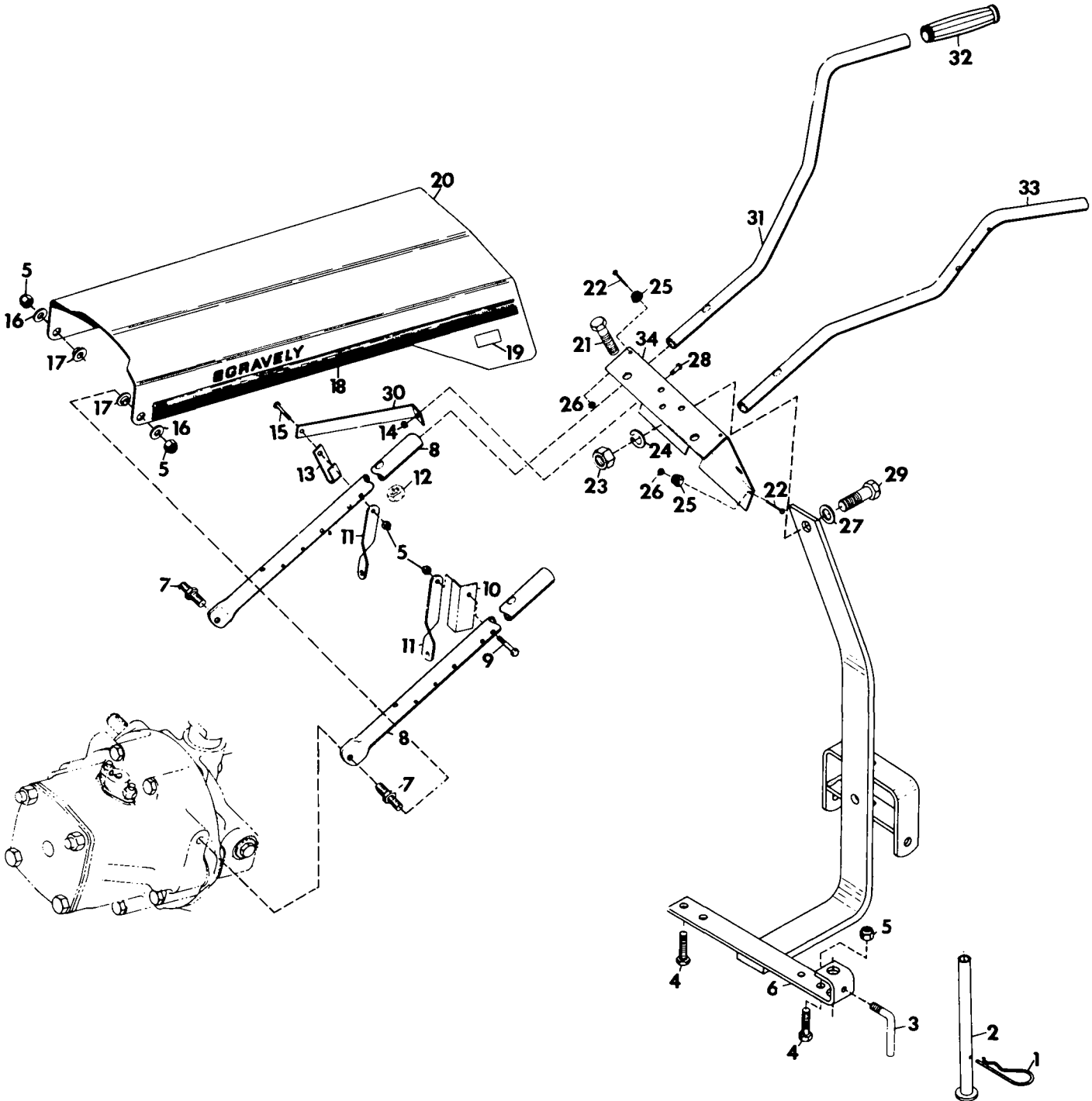

FRAME ASSEMBLY
(520, 521 & 524 TRACTORS)

<u>ITEM NO.</u>	<u>PART NO.</u>	<u>DESCRIPTION</u>
1.	10405P1	Cotter, Hair Pin
2.	20540A1	Weldment, Stand
3.	13457P1	Handle, Adjusting
4.	180126	Bolt, Hex; 3/8-16 x 1 1/2
5.	456004	Nut, Lock; 3/8-16 Washer Insert
6.	14941A1	Weldment, Rear Hitch; 8 H.P.
7.	21028P1	Stud, Hood
8.	10643P1	Tube, Support
9.	180132	Bolt, Hex; 3/8-16 x 2 1/4
10.	10933P1	Stop, Rod
11.	10655P1	Brace, Handle
12.	120371	Nut, Hex; 1/2-20
13.	10684P1	Retainer, 2-Speed Control (524)
14.	419454	Nut, Lock; 1/4-20 Washer Insert
15.	180134	Bolt, Hex; 3/8-16 x 2 1/2 (524)
	180132	Bolt, Hex; 3/8-16 x 2 1/4 (520,521)
16.	120394	Washer, Flat; 13/32 x 13/16 x .065
17.	11138P1	Bushing, Rear Fender
18.	21053P1	Decal, Commercial Manual L.H.
	21052P1	Decal, Commercial Manual R.H.
19.	21062P1	Decal, 520
	21313P1	Decal, 521
	21063P1	Decal, 524
20.	21027P1	Hood, Commercial
21.	181705	Bolt, Hex; 1/2-20 x 2
22.	159341	Screw, Machine; 6-32 x 5/8 Pan HD C-Recess
23.	124589	Nut, Hex; 5/8-11
24.	121574	Washer, Lock; 5/8 SP
25.	18183P1	Bumper
26.	427254	Nut, Lock; 6-32 Washer Insert
27.	421879	Washer, Flat; 21/32 x 1 1/4 x .100
28.	180018	Bolt, Hex; 1/4-20 x 5/8
29.	271547	Bolt, Hex; 5/8-11 x 1 1/2
30.	10996P1	Brace, Instrument Panel (524)
31.	10658P1	Bar, L. H. Handle
32.	10671P1	Grip, Hand
33.	11982P1	Bar, R. H. Handle
34.	21248P1	Panel, Instrument

FRAME ASSEMBLY

(522, 526, 546, 564 & 566 TRACTORS)

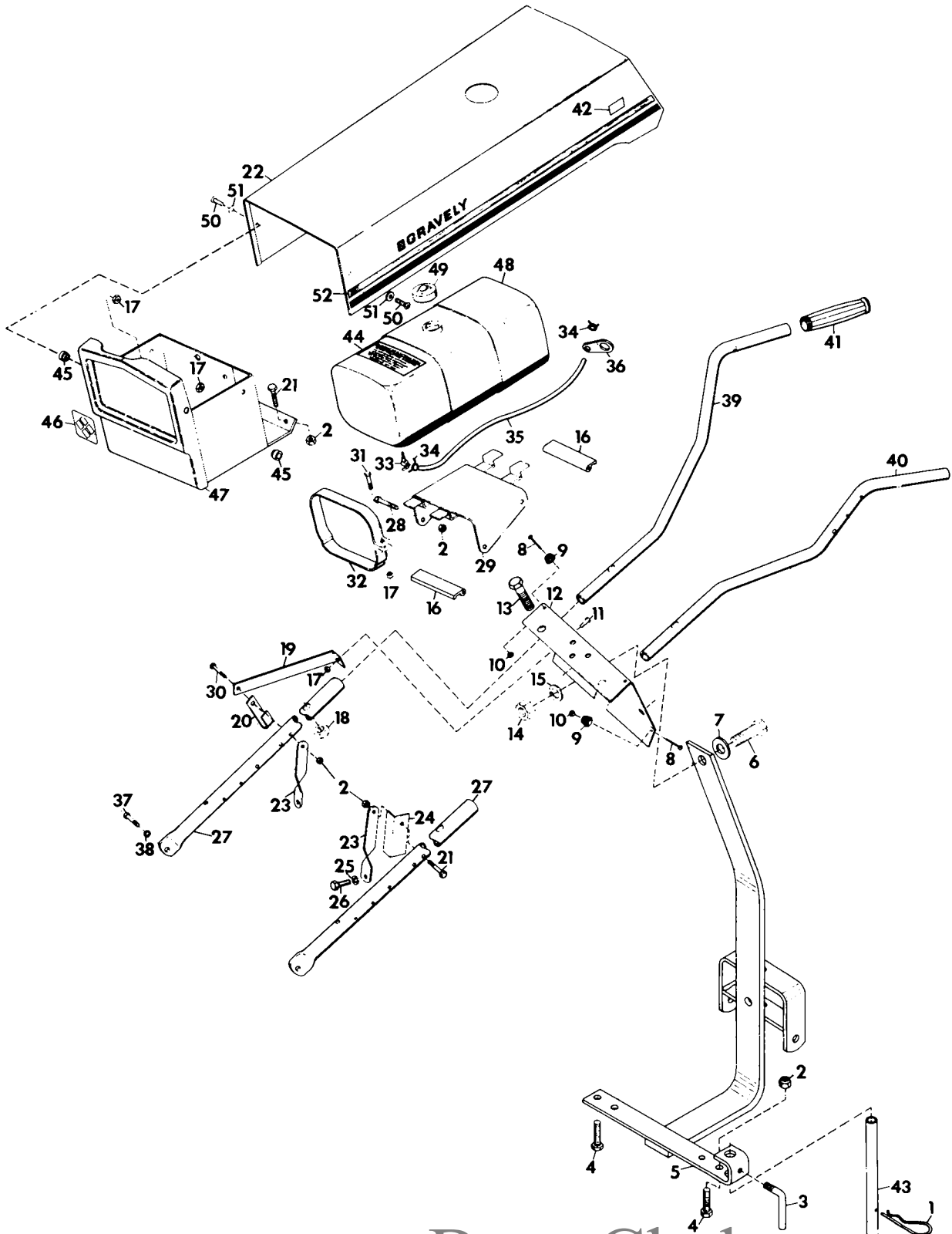

FRAME ASSEMBLY

(522, 526, 546, 564 & 566 TRACTORS)

<u>ITEM NO.</u>	<u>PART NO.</u>	<u>DESCRIPTION</u>
1.	10405P1	Cotter, Hair Pin
2.	456004	Nut, Lock; 3/8-16 Washer Insert
3.	13457P1	Handle, Adjusting
4.	180126	Bolt, Hex; 3/8-16 x 1 1/2
5.	14941A1	Weldment, Rear Hitch; Electric/Manual 8 HP (522,526)
	21227A1	Weldment, Rear Hitch 10 & 12 HP (546,564,566)
6.	271547	Bolt, Hex; 5/8-11 x 1 1/2
7.	421879	Washer, Flat; 21/32 x 1 1/4 x .100
8.	159341	Screw, Machine; 6-32 x 5/8 Pan HD C-Recess
9.	18183P1	Bumper
10.	427254	Nut, Lock; 6-32 Washer Insert
11.	180018	Bolt, Hex; 1/4-20 x 5/8 (526,546,564,566)
12.	21248P1	Panel, Instrument
13.	181705	Bolt, Hex; 1/2-20 x 2
14.	124589	Nut, Hex; 5/8-11
15.	121574	Washer, Lock; 5/8 SP
16.	18217P1	Moulding
17.	419454	Nut, Lock; 1/4-20 Washer Insert
18.	120371	Nut, Hex; 1/2-20
19.	10996P1	Brace, Instrument Panel (526,546,564,566)
20.	10684P1	Retainer, 2-Speed Control (526,546,564,566)
21.	180132	Bolt, Hex; 3/8-16 x 2 1/4
22.	10650P1	Hood
23.	10655P1	Brace, Handle
24.	10933P1	Rod, Stop
25.	131100	Washer, Lock; 7/16 SP Heavy
26.	180149	Bolt, Hex; 7/16-14 x 1 1/2
27.	10643P1	Tube, Support
28.	180129	Bolt, Hex; 3/8-16 x 1 7/8
29.	10637A1	Weldment, Fuel Tank Bracket
30.	180134	Bolt, Hex; 3/8-16 x 2 1/2 (526,546,564,566)
31.	180024	Bolt, Hex; 1/4-20 x 1 1/4
32.	10640P1	Strap, Fuel Tank
33.	7354A1	Valve and Strainer
34.	7216P1	Clamp, Fuel Hose
35.	10896P1	Line, Fuel
36.	21489P1	Bracket, Fuel Line (522,526)
37.	180122	Bolt, Hex; 3/8-16 x 1
38.	120382	Washer, Lock; 3/8 SP
39.	11982P1	Bar, R. H. Handle
40.	10658P1	Bar, L. H. Handle
41.	10671P1	Grip, Handle
42.	21064P1	Decal, 522
	21065P1	Decal, 526
	21066P1	Decal, 546
	21255P1	Decal, 564
	21067P1	Decal, 566
43.	20540A1	Weldment, Stand
44.	11989P1	Decal, Electrical System Warning (522,526,546,566)
45.	12117P1	Pivot, Hood
46.	10697P1	Decal, Commercial Front
47.	10644A1	Weldment, Grille
48.	10636A1	Assembly, Fuel Tank
49.	10756P1	Cap, Gas Tank
50.	160556	Screw, Machine; 1/4-20 x 1 Pan HD
51.	120392	Washer, Flat; 9/32 x 5/8 x .065
52.	21051P1	Decal, Commercial Hood L. H.
	21050P1	Decal, Commercial Hood R. H.

CONTROLS

(ALL 500 SERIES TRACTORS)

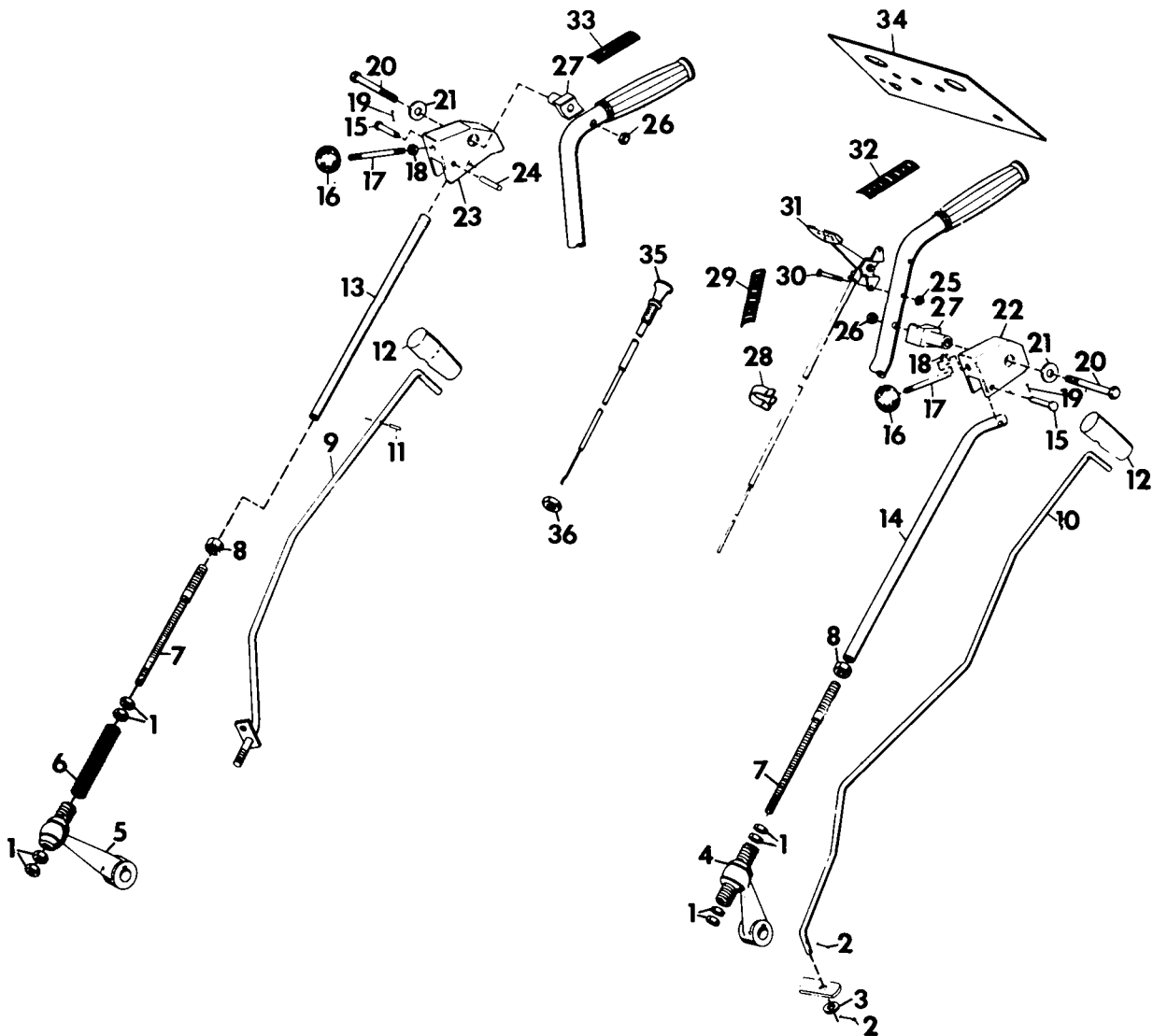

<u>ITEM NO.</u>	<u>PART NO.</u>	<u>DESCRIPTION</u>
1.	124829	Nut, Jam; 3/8-16
2.	121224	Pin, Cotter; 3/32 x 1
3.	120394	Washer, Flat; 13/32 x 13/16 x .065
4.	21383A1	Assembly, Hi-Lo Lever
5.	21384A1	Assembly, Fwd-Rev Lever
6.	21506P1	Spring, Fwd-Rev Neutral Return
7.	20269P1	Rod, Control Extension
8.	120238	Nut, Jam; 1/2-13
9.	10677A1	Weldment, 2-Speed Control Rod (524,526,546,564,566)
10.	10932P1	Rod, Attachment Throwout
11.	423664	Pin, Spring; 3/32 x 11/16 (524,526,546,564,566)
12.	10683P1	Handle, Rubber Shifter
13.	20267P1	Rod, Fwd-Rev Control
14.	20268P1	Rod, Hi-Lo Control
15.	10672P1	Pin, Clevis; .375 x 1.250
16.	10670P1	Knob, Control
17.	10669P1	Knob, Shifter
18.	272123	Nut, Jam; 7/16-10 Hex
19.	177923	Pin, Cotter; 1/8 x 3/4
20.	180192	Bolt, Hex; 1/2-13 x 3 1/2

BrentChalmers.com

CONTROLS

(ALL 500 SERIES TRACTORS)

<u>ITEM NO.</u>	<u>PART NO.</u>	<u>DESCRIPTION</u>
21.	120396	Washer, Flat; 17/32 x 1 1/16 x .095
22.	10666P1	Support, Hi-Lo Shifter Rod
23.	11985P1	Support, Fwd-Rev Shifter Rod
24.	453670	Pin, Spring; 1/4 x 1 1/8
25.	190254	Nut, Lock; 10-24 Washer Insert
26.	20541P1	Nut, Lock; 1/2-13 Washer Insert Thin
27.	10667P1	Pivot, Handle Lever
28.	8260P1	Clip, Conduit
29.	21091P1	Decal, Gear Shift
30.	436738	Screw, Machine; 10-24 x 1 1/2 Pan HD
31.	21103P1	Lever, Throttle Control; (520,521,522,524,526)
	21196P1	Lever, Throttle Control; (546,564,566)
32.	21092P1	Decal, Throttle
33.	21090P1	Decal, Fwd-Rev
34.	21106P1	Decal, Instrument Panel (Manual)
	21105P1	Decal, Instrument Panel (Electric)
35.	10696P1	Control, Choke (522,526,546,566)
36.	124925	Nut, Jam; 3/8-24 (522,526,546,566)

WHEEL ASSEMBLY

(ALL 500 SERIES TRACTORS)

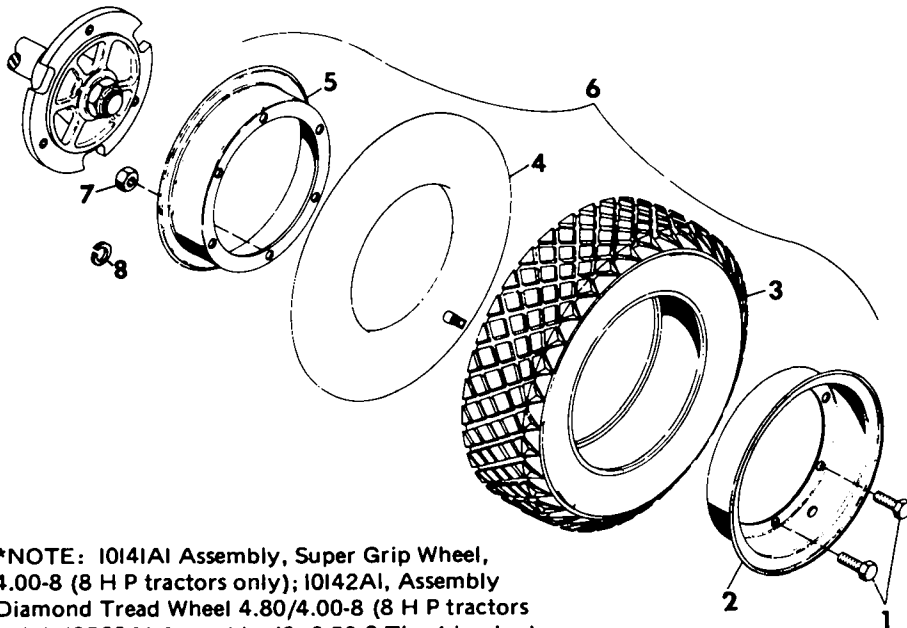

*NOTE: I0I4IAI Assembly, Super Grip Wheel, 4.00-8 (8 H P tractors only); I0I42AI, Assembly Diamond Tread Wheel 4.80/4.00-8 (8 H P tractors only); I9563AI Assembly, 18x6.50-8 Tire (standard 546, 564, 566, optional all 8 H P tractors)

<u>ITEM NO.</u>	<u>PART NO.</u>	<u>DESCRIPTION</u>
1.	428638	Bolt, Hex; 3/8-16 x 5/8
	180120	Bolt, Hex; 3/8-16 x 3/4 (Semi-Pneumatic Wheel Asm)
2.	12673P1	Disc, Wheel
3.	13836P1	Tire, Tractor D.T. (4.80 x 4.00-8)
	13835P1	Tire, Tractor G.G. (4.80 x 4.00-8)
	11645P1	Tire, 18 x 6.50-8
4.	11637P1	Tube, Puncture Proof
	11645P1	Tube, 5.00 x 8 (18 x 6.50-8)
5.	12674P1	Disc, Inner Wheel
* 6.	10141AI	Assembly, Super Grip Wheel
	10142AI	Assembly, Diamond Tread Wheel
	19563AI	Assembly, 18 x 6.50-8 Tire (46, 54, 56)
7.	124829	Nut, Jam; 3/8-16
8.	120382	Washer, Lock; 3/8 SP (Semi-Pneumatic Wheel Asm.)

REMOTE AIR CLEANER (564 TRACTORS ONLY)

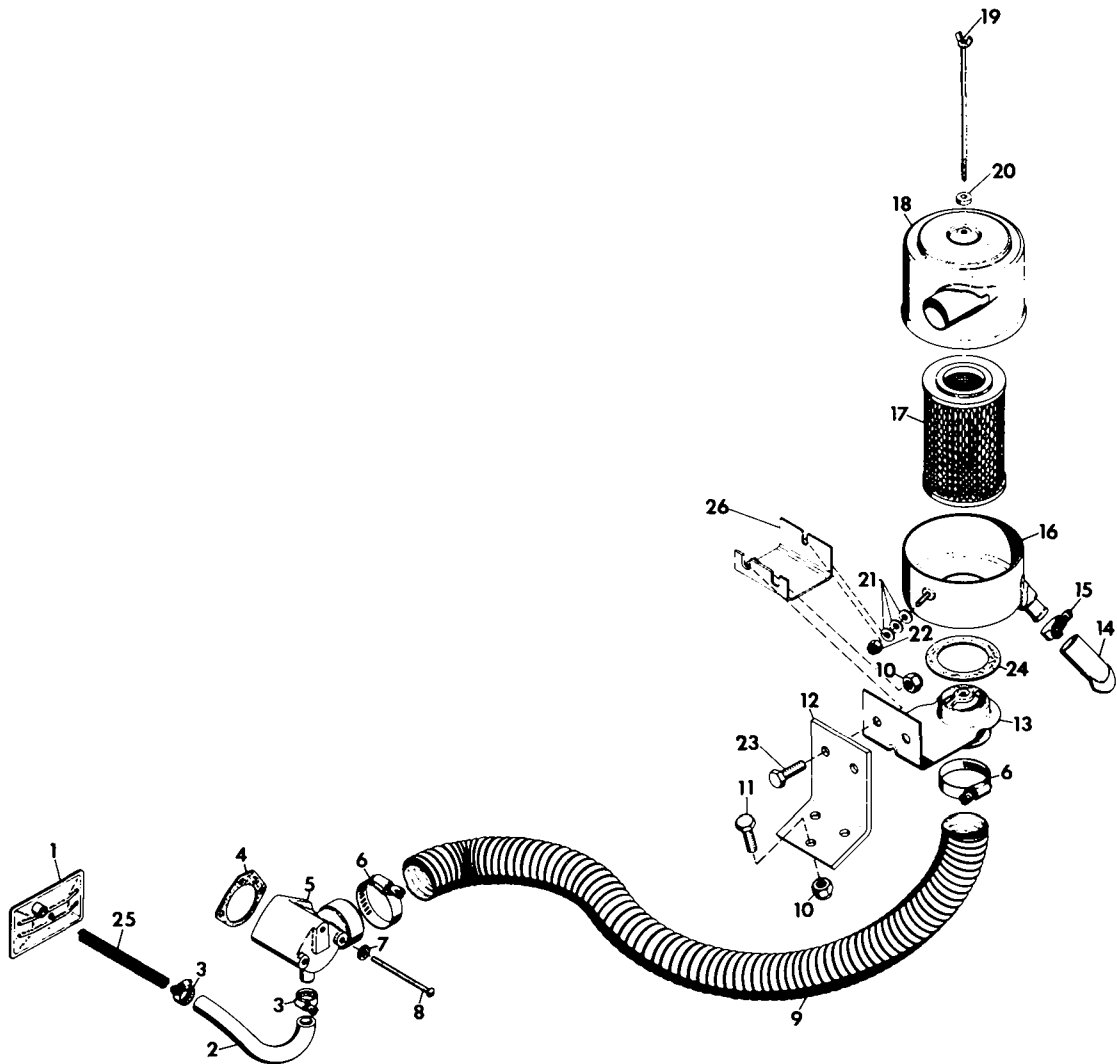

<u>ITEM NO.</u>	<u>PART NO.</u>	<u>DESCRIPTION</u>
1.	21320P1	Plate, Breather
2.	21232P1	Hose, Crankcase Ventilation
3.	21247P1	Clamp, .88 Dia Hose
4.	21229P1	Gasket, Air Cleaner Elbow
5.	21235P1	Elbow, Air Cleaner
6.	21245P1	Clamp, 2.25 Dia Hose
7.	113893	Washer, Copper; .219 x .500 x .049
8.	436762	Screw, Mach 10-32 x 3 Pan HD
9.	21233P1	Hose, Air Cleaner
10.	456004	Nut, Lock; 3/8-16 Washer Insert Hex
11.	180122	Bolt, Hex; 3/8-16 x 1
12.	21234P1	Bracket, Air Cleaner To Tractor
13.	21337P1	Bracket, Air Cleaner
14.	21335P1	Hose, Unloader
15.	21334P1	Clamp, 1.38 Dia Hose
16.	21332P1	Housing, Lower
17.	21333P1	Filter Element
18.	21331P1	Housing, Upper
19.	21330P1	Bolt, Special Air Cleaner
20.	10905P1	Washer, Sealing
21.	120392	Washer, Flat; 9/32 x 5/8 x .065
22.	419454	Nut, Lock; 1/4-20 Washer Insert
23.	180123	Bolt, Hex; 3/8-16 x 1 1/8
24.	21336P1	Gasket, Air Cleaner
25.	21375P1	Spring, Compression; .480 x 20 Lt/in
26.	21473P1	Support, Remote Air Cleaner

Brent Chalmers.com

ENGINE AND EXHAUST SYSTEM (ALL 500 SERIES TRACTORS)

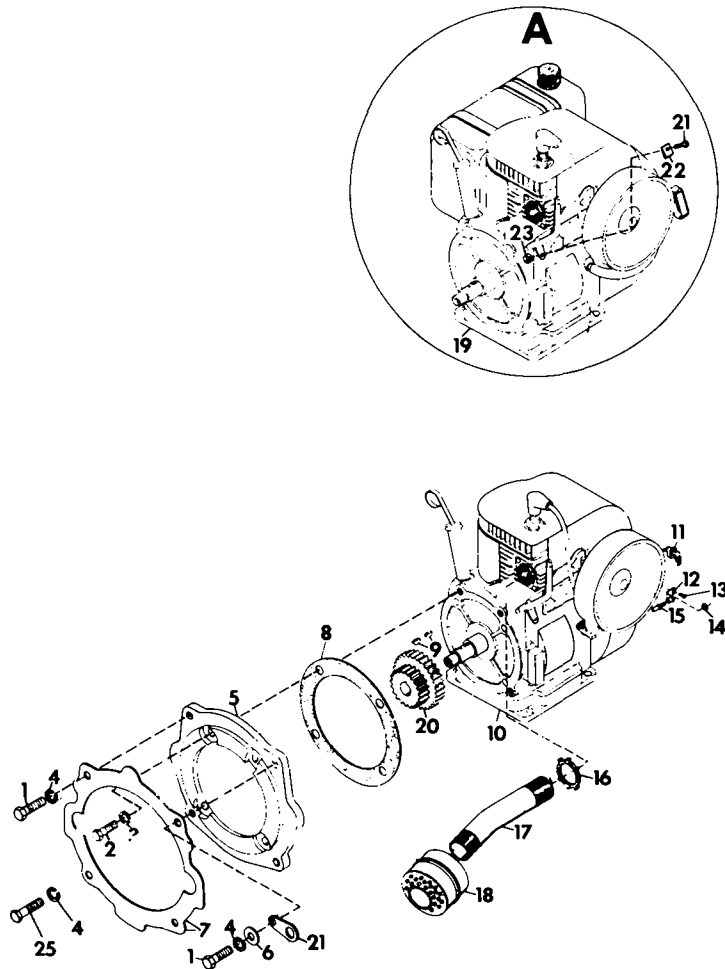

ITEM NO.	PART NO.	DESCRIPTION
1.	180149	Bolt, Hex; 7/16-14 x 1 1/2
2.	180121	Bolt, Hex; 3/8-16 x 7/8 (520,521,522,524,526)
	180122	Bolt, Hex; 3/8-16 x 1 (546,564,566)
3.	131099	Washer, Lock; 3/8 SP Heavy
4.	131100	Washer, Lock; 7/16 SP Heavy
5.	14938P1	Adapter, Engine (520,521,522,524,526)
	10731P1	Adapter, Engine (546,564,566)
6.	120388	Washer, Flat; 7/16 x 1 x .083
7.	10635P1	Gasket, Chassis to Adapter
8.	15718P1	Gasket, Engine to Adapter (520,521,522,524,526)
	10732P1	Gasket, Engine to Adapter (546,564,566)
9.	124545	Key, Woodruff; 5/32 x 5/8 Hard
10.	21137A1	Engine, 10 HP (546)
	21228A1	Engine, 12 HP; Manual Start (564)
	21138A1	Engine, 12 HP; Electric Start (566)
11.	7331P1	Clip, Speed
12.	18522P1	Bracket
13.	160515	Screw, Machine; 1/4-20 x 1/2 Pan HD
14.	120375	Nut, Hex; 1/4-20
15.	18521P1	Adapter, Conduit
16.	10866P1	Nut, Conduit; 1" Pipe
17.	10865P1	Tube, Muffler
18.	8227P1	Muffler
19.	21042A1	Engine, 8 HP; Manual Start (520,521,524)
	21036A1	Engine, 8 HP; Electric Start (522,526)
20.	17838P1	Gear; 10/12 DP, 21/30 Teeth
21.	159920	Screw, Machine; 10-24 x 1/2 Pan HD
22.	15453P1	Clip
23.	190254	Nut, Lock; 10-24 Washer Insert
24.	21489P1	Bracket, Fuel Line (522,526 Only)
25.	180147	Bolt, Hex; 7/16-14 x 1 1/4 (520,521,522,524,526)
	180146	Bolt, Hex; 7/16-14 x 1 1/8 (546,564,566)

NOTE: Circle "A" Pertains to 8 HP Tractors Only

ELECTRICAL SYSTEM

(ALL 500 SERIES TRACTORS)

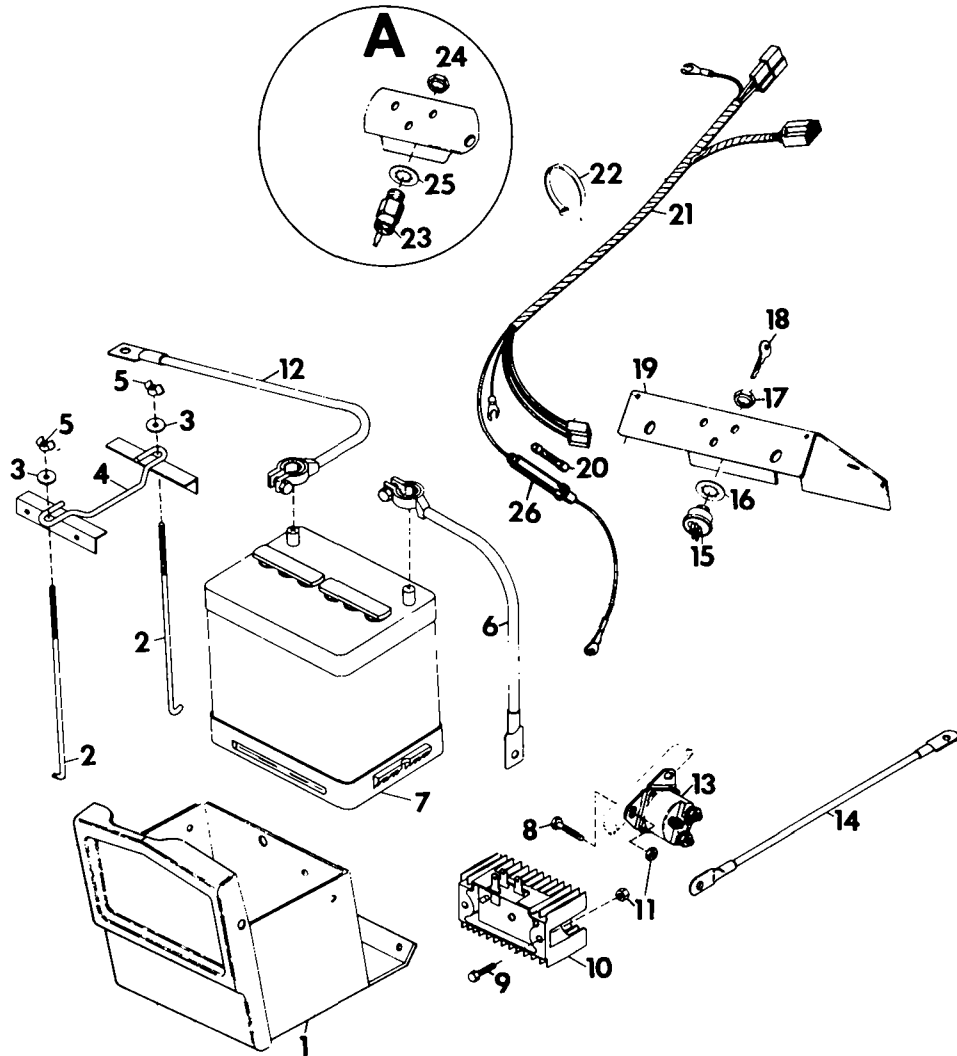

ITEM NO.	PART NO.	DESCRIPTION
1.	10644A1	Weldment, Grille
2.	12894P1	Bolt, Hold Down
3.	446354	Washer, Flat; 5/16 x 7/8 x .065
4.	10633P1	Clamp, Battery Hold Down
5.	10413P1	Nut, Wing; 1/4-20 Washer Insert
6.	6980P1	Cable, Negative Battery
7.	7274P1	Battery, 12 Volt
8.	180042	Bolt, Hex; 1/4-20 x 1 3/4
9.	180020	Bolt, Hex; 1/4-20 x 3/4
10.	18009P1	Regulator, Rectifier
11.	120375	Nut, Hex; 1/4-20
12.	21368P1	Cable, Positive Battery
13.	7277P1	Switch, Magnetic
14.	6981P1	Cable, Magnetic Switch to Starter
15.	19223P1	Switch, Ignition
16.	19667P1	Washer, Lock; 9/16 Internal Tooth
17.	19666P1	Nut, Jam; 9/16-24
18.	18570P1	Key, Ignition Switch
19.	21248P1	Panel, Instrument
20.	14893P1	Fuse, 30 AMP; Acc 30
21.	19222P1	Harness, Wiring
22.	10629P1	Tie, Cable
23.	21104P1	Switch, Ignition
24.	18585P1	Nut, Jam; 5/8-32
25.	18586P1	Washer, Lock; 5/8 Internal Tooth
26.	17124P1	Holder, 30 AMP Fuse Assembly

NOTE: Circle "A" Pertains to Manual Start Tractors Only

WIRING DIAGRAM

(FOR 500 SERIES ELECTRIC START TRACTORS)

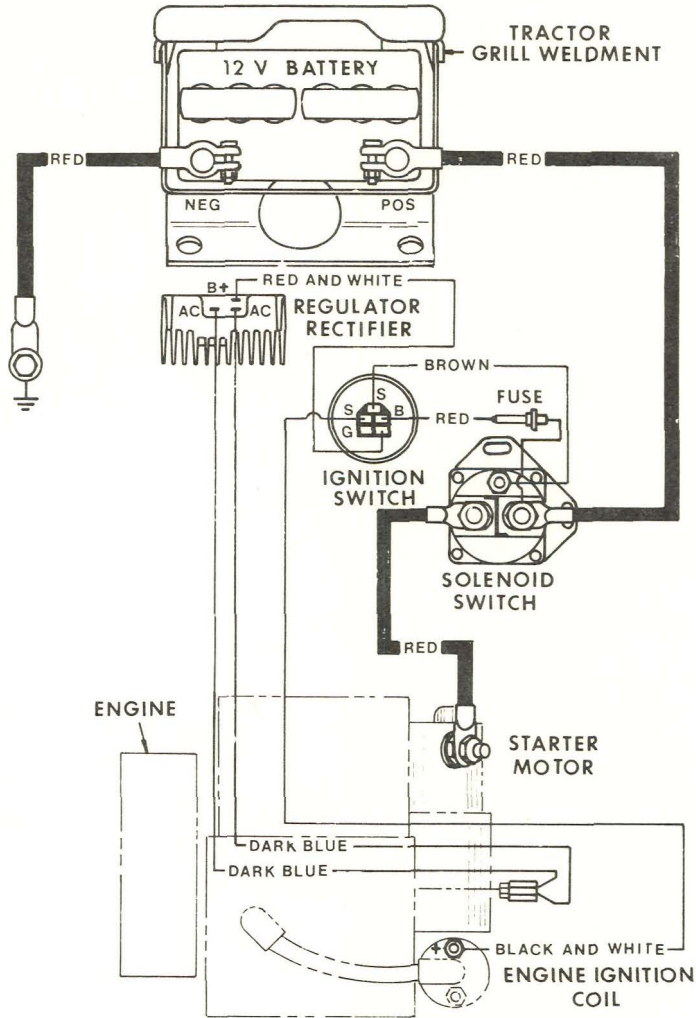

WIRING DIAGRAM

(FOR 500 SERIES MANUAL START TRACTORS)

