

GRAVELLY®

**800 SERIES
RIDING
TRACTOR
ILLUSTRATED
PARTS LIST**

800 Series Riding Tractor Illustrated Parts List

Model No.	21440	810
"	21441	812
"	21442	812 Hydraulic
"	21443	816S
"	23296	816T
"	23308	818T

TO CONTINUE ITS PROGRAM OF QUALITY AND DESIGN IMPROVEMENT, THE MANUFACTURER RESERVES THE RIGHT TO CHANGE SPECIFICATIONS, DESIGNS AND PRICES WITHOUT NOTICE AND WITHOUT INCURRING OBLIGATION



1 Gravelly Lane
Clemmons, N. C. 27012

TABLE OF CONTENTS

	Page
Transmission Assembly	1
Number 1 Shaft, Forward Clutch	2
Number 2 Shaft, Reverse Clutch	3
Number 3 Shaft, 3rd & 4th Gear	3
Number 4 Shaft, Idler	4
Number 5 Shaft, 1st & 2nd Gear	4
Number 6 Shaft, Brake & Sliding Gear	5
Number 7 Shaft, Shaft, Pinion & Final	6
Number 8 Shaft, Differential Assembly	6
Number 9 Shaft, PTO Clutch Assembly	7
Number 10 Shaft, PTO Drive Assembly	8
Number 11, Forward-Reverse Clutch Assembly	8
Number 12, Transmission Case Assembly	9
Number 13, Transmission Cover Assembly	10
Manual Lift Controls	11
Hydraulics System	12
Steering System	14
Front & Rear Wheel Assembly	15
Transmission & Brake Controls	16
Tractor Frame Assembly	18
Rear Hitch, 810, 812 & 816S	20
Rear Hitch, 816T & 818T	20
Fuel, Engine & Exhaust System, 810 & 812	21
Fuel, Engine & Exhaust System, 816S	22
Fuel, Engine & Exhaust System, 816T & 818T	23
Electrical System, 810	24
Electrical System, 812	25
Electrical System, 816S	26
Electrical System, 816T, 818T	27
Wiring Diagram, 810	28
Wiring Diagram, 812	29
Wiring Diagram, 816S	30
Wiring Diagram, 816T & 818T	inside back cover

TRANSMISSION ASSEMBLY

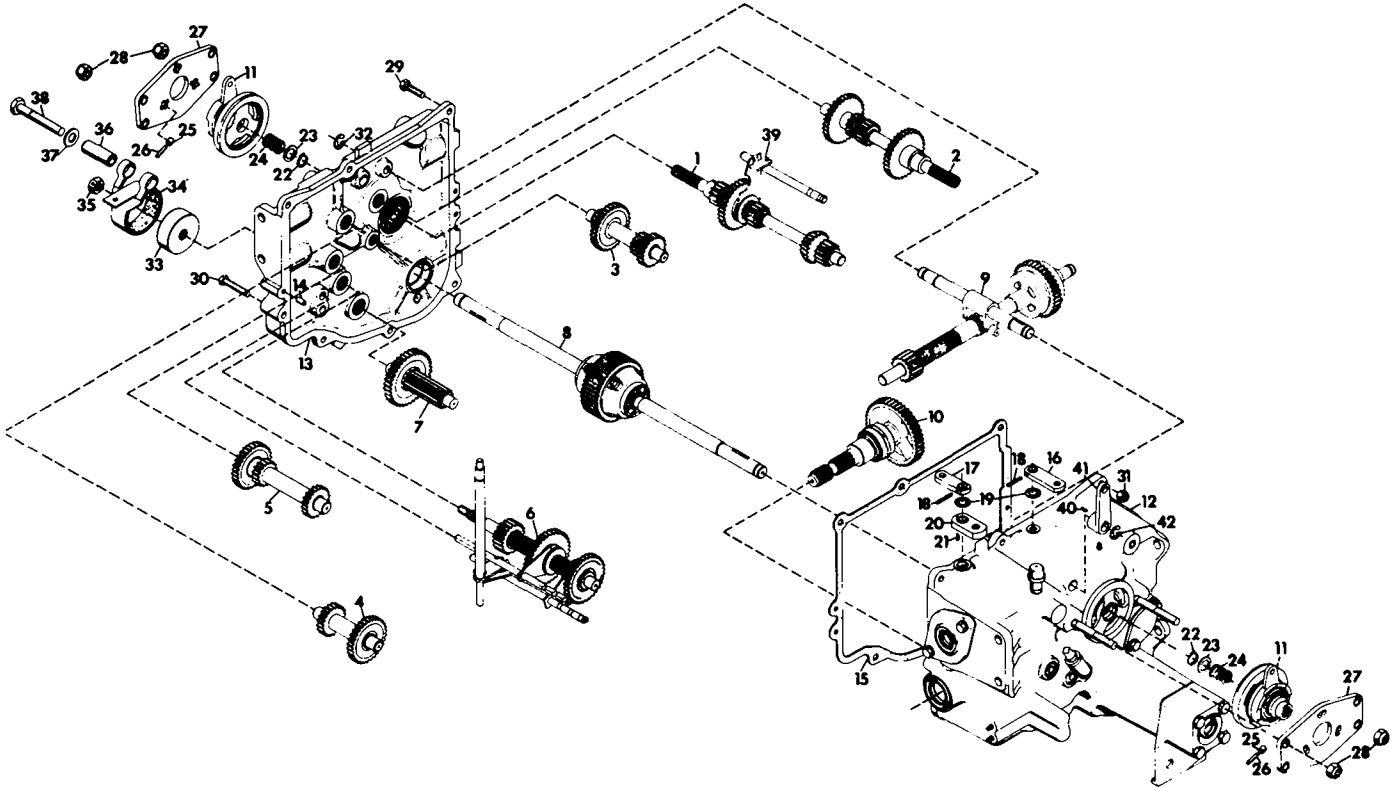

ITEM NO.	PART NO.	DESCRIPTION
1.	Refer To:	Number 1 Shaft, Forward Clutch
2.	Refer To:	Number 2 Shaft, Reverse Clutch
3.	Refer To:	Number 3 Shaft, 3rd and 4th Gear
4.	Refer To:	Number 4 Shaft, Idler
5.	Refer To:	Number 5 Shaft, 1st and 2nd Gear
6.	Refer To:	Number 6 Shaft, Brake and Sliding Gear
7.	Refer To:	Number 7 Shaft, Pinion and Final Drive
8.	Refer To:	Number 8 Shaft, Differential Assembly
9.	Refer To:	Number 9 Shaft, PTO Clutch Assembly
10.	Refer To:	Number 10 Shaft, PTO Drive Assembly
11.	Refer To:	Number 11, Forward-Reverse Clutch Assembly
12.	Refer To:	Number 12, Transmission Case Assembly
13.	Refer To:	Number 13, Transmission Cover Assembly
14.	18089P1	Pin, Dowel; 3/8 x 5/8
15.	18027P1	Gasket, Transmission Cover
16.	17929P1	Arm, Shifter
17.	17945P1	Arm, Shifter
18.	9421202	Pin, Spring; .187 x 1.0
19.	21141P1	Washer, Felt; (Special Trans.)
20.	17944P1	Arm, Shifter
21.	271089	Key, Woodruff; .125 x .375, Hard
22.	11135P1	Ring, Retaining
23.	11223P1	Race, Bearing Thrust; .752 x 1.240 x .030
24.	20444P1	Spring, Compression; 1.0 x .80 x 36 Lb/in
25.	18166P1	Roller, Clutch
26.	18167P1	Pin, Clutch
27.	18047P1	Plate, Clutch
28.	190171	Nut, Lock; 1/2-20 Washer Insert
29.	180126	Bolt, Hex; 3/8-16 x 1 1/2
30.	180132	Bolt, Hex; 3/8-16 x 2 1/4
31.	456004	Nut, Lock; 3/8-16 Washer Insert
32.	11270P1	E-Ring
33.	21371P1	Drum, Brake
34.	18162A1	Assembly, Band Brake
35.	414075	Nut, Lock; 5/8-11 Type N
36.	18165P1	Bushing; .530 x .750 x 2.06
37.	120396	Washer, Flat; .531 x 1.06 x .095
38.	180188	Bolt, Hex; 1/2-13 x 2 3/4
39.	17926A1	Weldment, Shifter
40.	124549	Key, Woodruff; .187 x .750, Hard
41.	18019P1	Lever, PTO

NUMBER 1 SHAFT, FORWARD CLUTCH

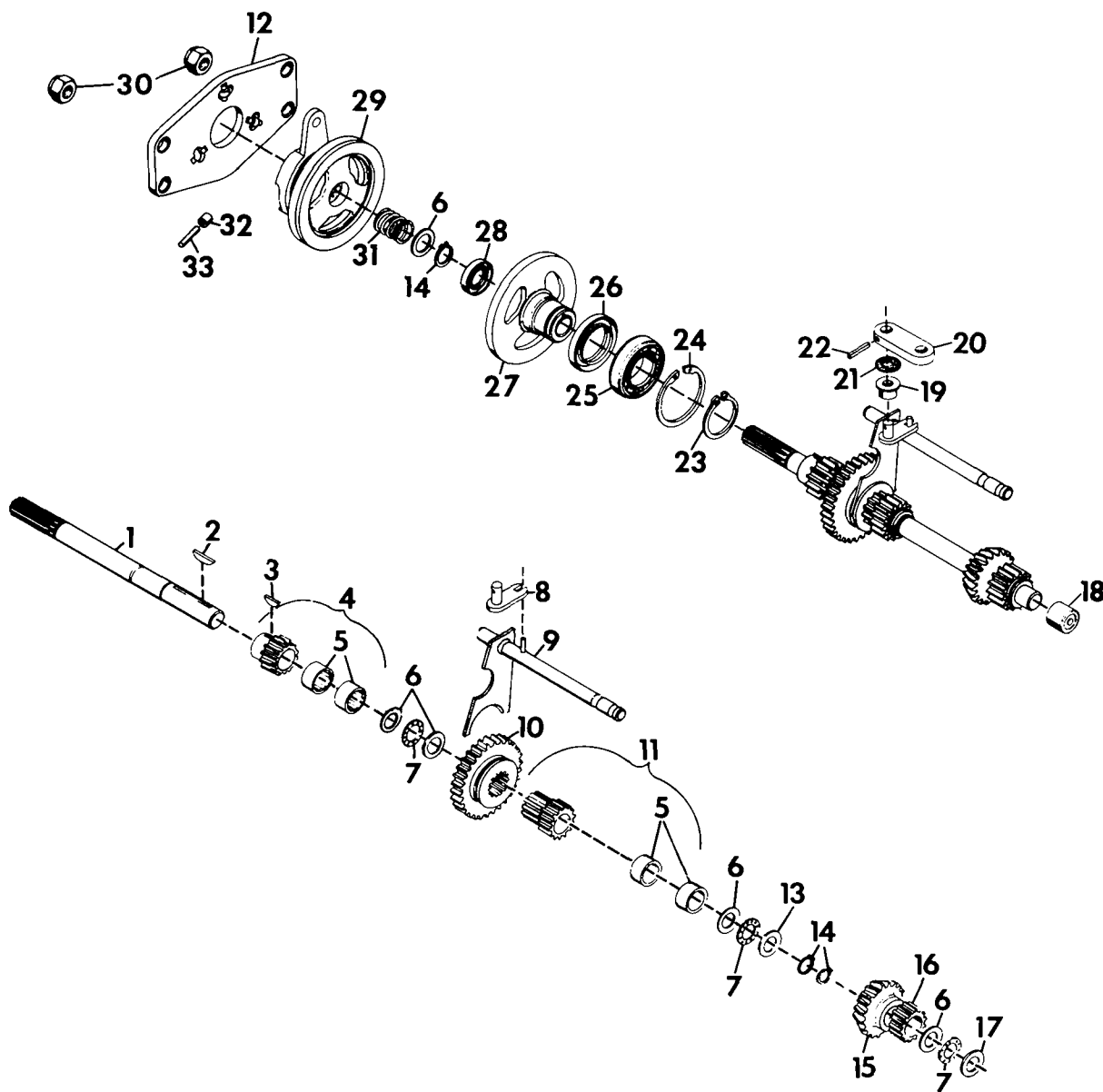

ITEM NO.	PART NO.	DESCRIPTION
1.	20447P1	Shaft, Splined Forward Clutch
2.	117989	Key, Woodruff; 3/16 x 1 1/4 Hard
3.	431787	Key, Woodruff; 3/16 x 5/8 Hard
4.	18025A1	Assembly, Gear and Bearing; #1 Shaft, Clutch Side
5.	17949P1	Bearing, Needle; .750 x 1.00 x .500
6.	11223P1	Race, Bearing Thrust; .752 x 1.240 x .030
7.	6741P1	Bearing, Needle Thrust; .752 x 1.240 x .078
8.	17926A1	Weldment, Shifter
9.	20755A1	Weldment, 2-Speed Shift Rail
10.	18011P1	Gear, Spur; 2 Speed, 10 DP, 36 Teeth x .750
11.	18007A1	Assembly, Gear and Bearing; 10 DP, 16 Teeth x 1.750
12.	18047P1	Plate, Clutch
13.	6742P1	Race, Bearing, Thrust; .752 x 1.240 x .060
14.	11135P1	Ring, Retaining
15.	18006P1	Gear, Bevel; 10 DP, 25 Teeth x .9025
16.	18003P1	Gear, Spur; 10 DP, 16 Teeth x .75 Standard
17.	14998P1	Race, Bearing Thrust; .752 x 1.240 x .090
18.	17913P1	Bearing, Needle; .750 x 1.00 x .750
19.	17925P1	Bushing, 2-Speed
20.	17929P1	Arm, Shifter
21.	21141P1	Washer, Felt; (Special Trans.)
22.	9421202	Pin, Spring; .187 x 1.00
23.	17919P1	Ring, Retaining
24.	18872P1	Ring, Retaining
25.	17915P1	Bearing, Ball; 1.968 x 1.3780 x .433
26.	17917P1	Seal, Oil; 2.250 x 3.005 x .375
27.	18024P1	Hub, Clutch
28.	18035P1	Seal, Oil; .750 x 1.625 x .250
29.	190171	No. 11, Forward-Reverse Clutch Assembly
30.	190171	Nut, Lock; 1/2-20 Washer Insert
31.	20444P1	Spring, Compression; 1.0 x .80 x 36 Lb/in
32.	18166P1	Roller, Clutch
33.	18167P1	Pin, Clutch
34.	18047P1	Plate, Clutch

NUMBER 2 SHAFT, REVERSE CLUTCH

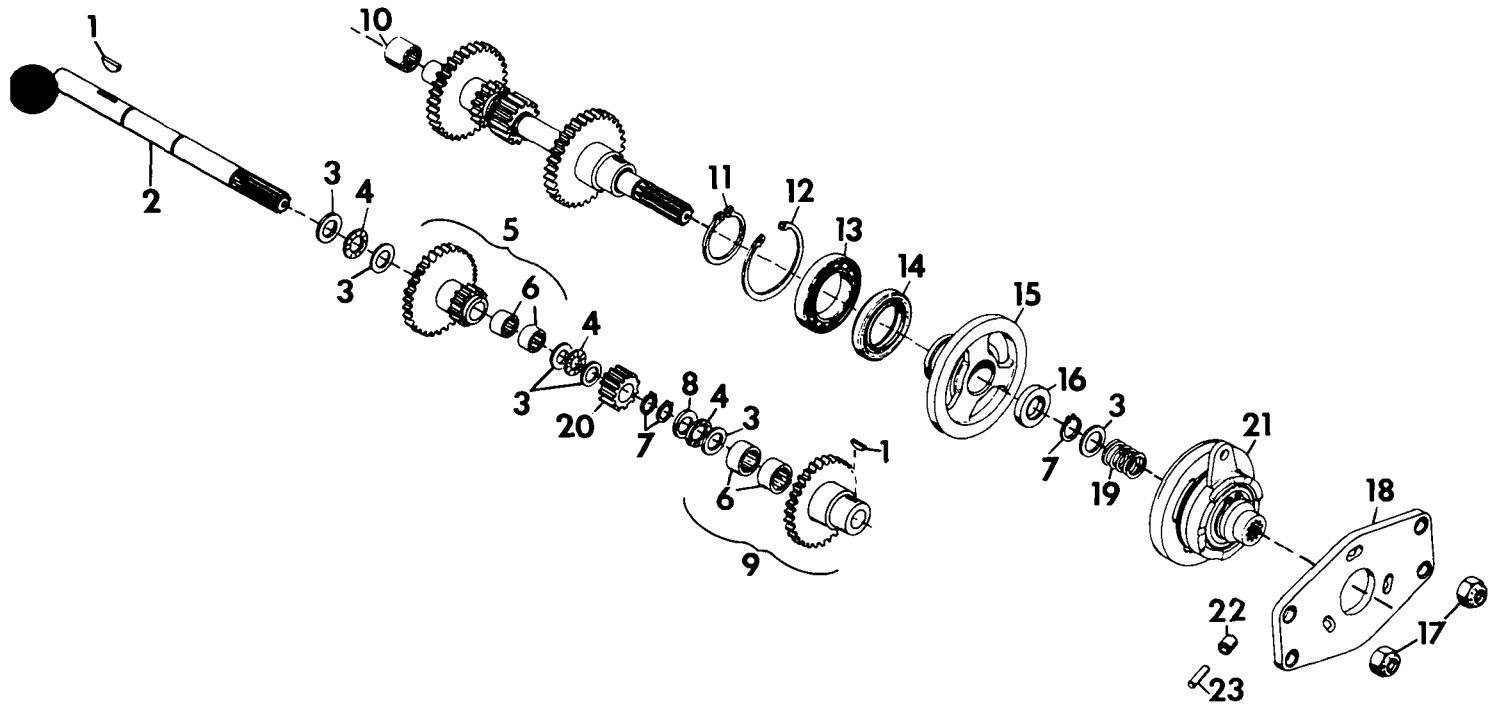

ITEM NO.	PART NO.	DESCRIPTION
1.	431787	Key, Woodruff; 3/16 x 5/8 Hard
2.	20448P1	Shaft, Splined Reverse Clutch
3.	11223P1	Race, Bearing Thrust; .752 x 1.240 x .030
4.	6741P1	Bearing, Needle Thrust; .752 x 1.240 x .078
5.	18020A1	Assembly, Idler Gear
6.	17949P1	Bearing, Needle; .750 x 1.00 x .500
7.	11135P1	Ring, Retaining
8.	6742P1	Race, Bearing Thrust; .752 x 1.240 x .060
9.	17947A1	Assembly, Reverse Gear and Bearing
10.	17913P1	Bearing, Needle; .750 x 1.00 x .750
11.	17919P1	Ring, Retaining
12.	18872P1	Ring, Retaining
13.	17915P1	Bearing, Ball; 1.968 x 3.149 x .629
14.	17917P1	Seal, Oil; 2.250 x 1.378 x .433
15.	18024P1	Hub, Clutch
16.	18035P1	Seal, Oil; .750 x 1.625 x .250
17.	190171	Nut, Lock; 1/2-20 Washer Insert
18.	18047P1	Plate, Clutch
19.	20444P1	Spring, Compression; 1.0 x .80 x 36 Lb/in
20.	18003P1	Gear, Spur; 10 DP, 16 Teeth x .750 Standard
21.		Number 11, Forward-Reverse Clutch Assembly
22.	18166P1	Roller, Clutch
23.	18167P1	Pin, Clutch

NUMBER 3 SHAFT, 3rd & 4th GEAR

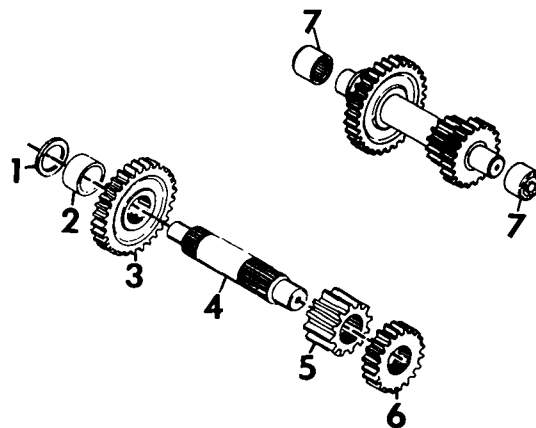

ITEM NO.	PART NO.	DESCRIPTION
1.	18000P1	Race, Bearing Thrust; .627 x 1.115 x .090
2.	17999P1	Spacer; 1.027 x 1.175 x .757
3.	19535P1	Gear, Spur; 10 DP, 16 Teeth x .500
4.	17997P1	Shaft, Splined
5.	17992P1	Gear, Spur; 10 DP, 16 Teeth x .750
6.	15118P1	Gear, Spur; 10 DP, 20 Teeth x .600
7.	17914P1	Bearing, Needle; .625 x .812 x .750

NUMBER 4 SHAFT, IDLER

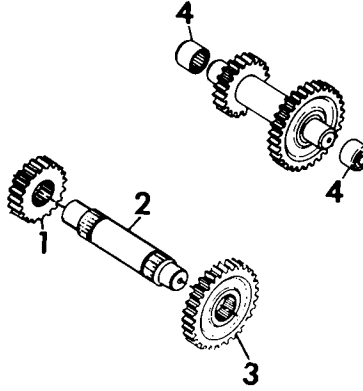

<u>ITEM NO.</u>	<u>PART NO.</u>	<u>DESCRIPTION</u>
1.	15118P1	Gear, Spur; 10 DP, 20 Teeth x .600
2.	17995P1	Shaft, Splined
3.	15115P1	Gear, Spur; 10 DP, 30 Teeth x .500
4.	17913P1	Bearing, Needle; .750 x 1.00 x .750

NUMBER 5 SHAFT, 1st & 2nd GEAR

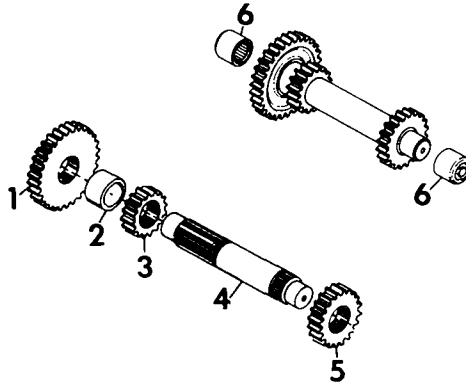

<u>ITEM NO.</u>	<u>PART NO.</u>	<u>DESCRIPTION</u>
1.	15115P1	Gear, Spur; 10 DP, 30 Teeth x .500
2.	17993P1	Spacer; 1.057 x 1.250 x .550
3.	17992P1	Gear, Spur; 10 DP, 16 Teeth x .750
4.	17989P1	Shaft, Splined
5.	15118P1	Gear, Spur; 10 DP, 20 Teeth x .600
6.	17913P1	Bearing, Needle; .750 x 1.00 x .750

NUMBER 6 SHAFT, BRAKE & SLIDING GEAR

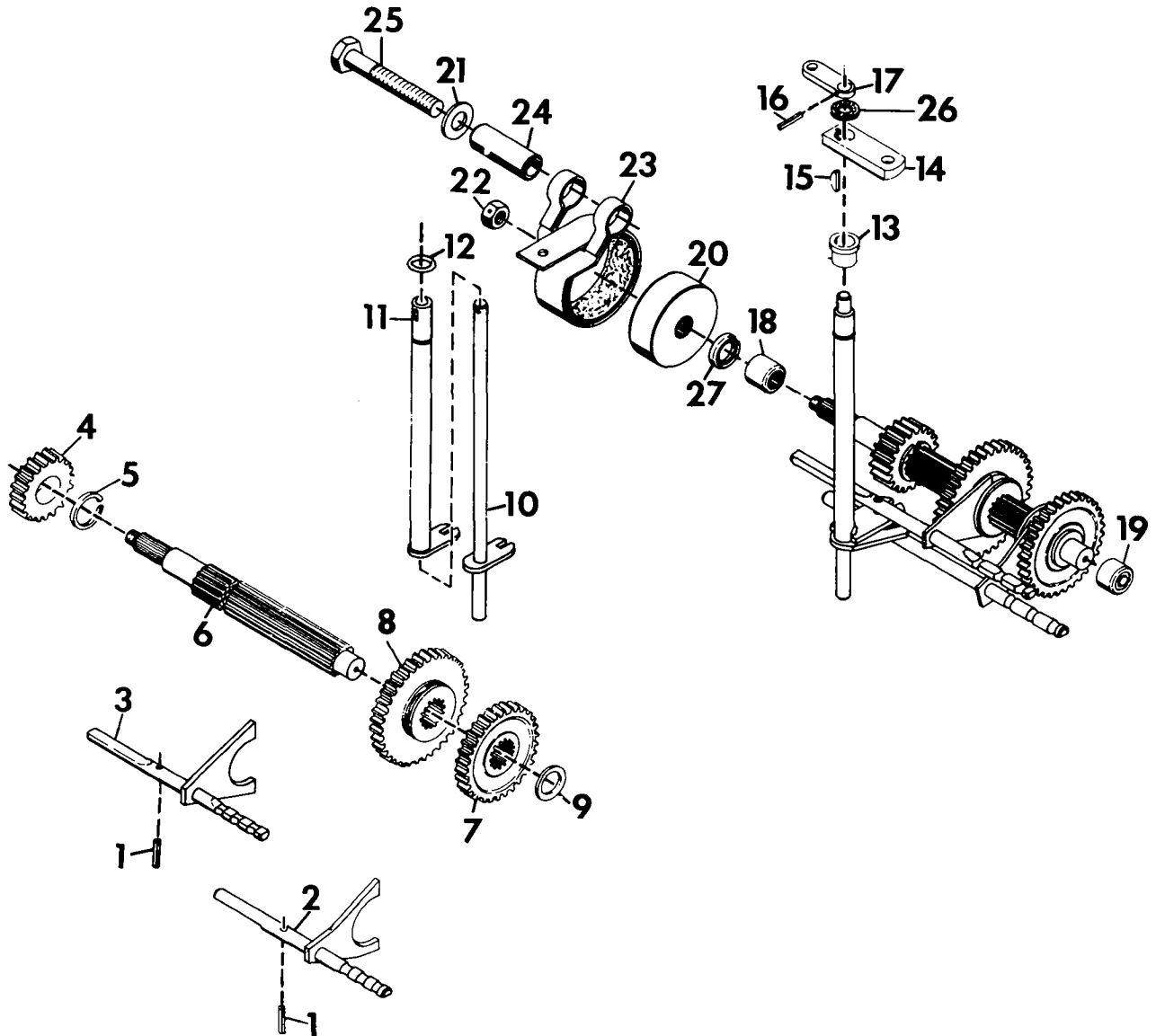

ITEM NO.	PART NO.	DESCRIPTION
1.	456390	Pin, Spring; .25 x .75
2.	20762A1	Weldment, Fork Rail Shift
3.	20761A1	Weldment, Fork Rail Shift
4.	14988P1	Gear, Spur; 8 DP, 16 Teeth x .850
5.	14987P1	Ring, Retaining
6.	21370P1	Shaft, Sliding Gear
7.	14995P1	Gear, Sliding; 10 DP, 30 Teeth x .594
8.	14989P1	Gear, Sliding; 10 DP, 36 Teeth x .594
9.	14998P1	Race, Bearing Thrust; .752 x 1.240 x .090
10.	17937A1	Weldment, Shifter
11.	17940A1	Weldment, Shifter
12.	18018P1	O-Ring; .625 x .750 x .062
13.	17943P1	Bushing
14.	17944P1	Arm, Shifter
15.	271089	Key, Woodruff; .125 x .375, Hard
16.	9421202	Pin, Spring; .187 x 1.00
17.	17945P1	Arm, Shifter
18.	11063P1	Bearing, Needle; .750 x 1.00 x .750
19.	17913P1	Bearing, Needle; .750 x 1.00 x .750
20.	21371P1	Drum, Brake
21.	120396	Washer, Flat; .531 x 1.06 x .095
22.	414075	Nut, Lock; 5/8-11 Type N
23.	18162A1	Assembly, Band Brake
24.	18165P1	Bushing; .530 x .750 x 2.06
25.	180188	Bolt, Hex; 1/2-13 x 2 3/4
26.	21141P1	Washer, Felt; Special Trans.
27.	15137P1	Seal Oil; .750 x 1.24 x .183

NUMBER 7 SHAFT, PINION & FINAL DRIVE

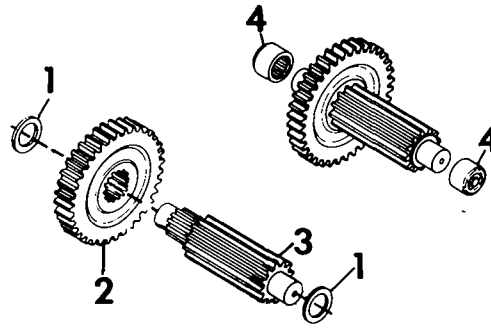

ITEM NO.	PART NO.	DESCRIPTION
1.	19340P1	Race, Bearing Thrust; 1.002 x 1.552 x .030
2.	17987P1	Gear, Spur; 8 DP, 30 Teeth x .750
3.	17986P1	Pinion, Final Drive
4.	17912P1	Bearing, Needle; 1.00 x 1.25 x .750

NUMBER 8 SHAFT, DIFFERENTIAL ASM.

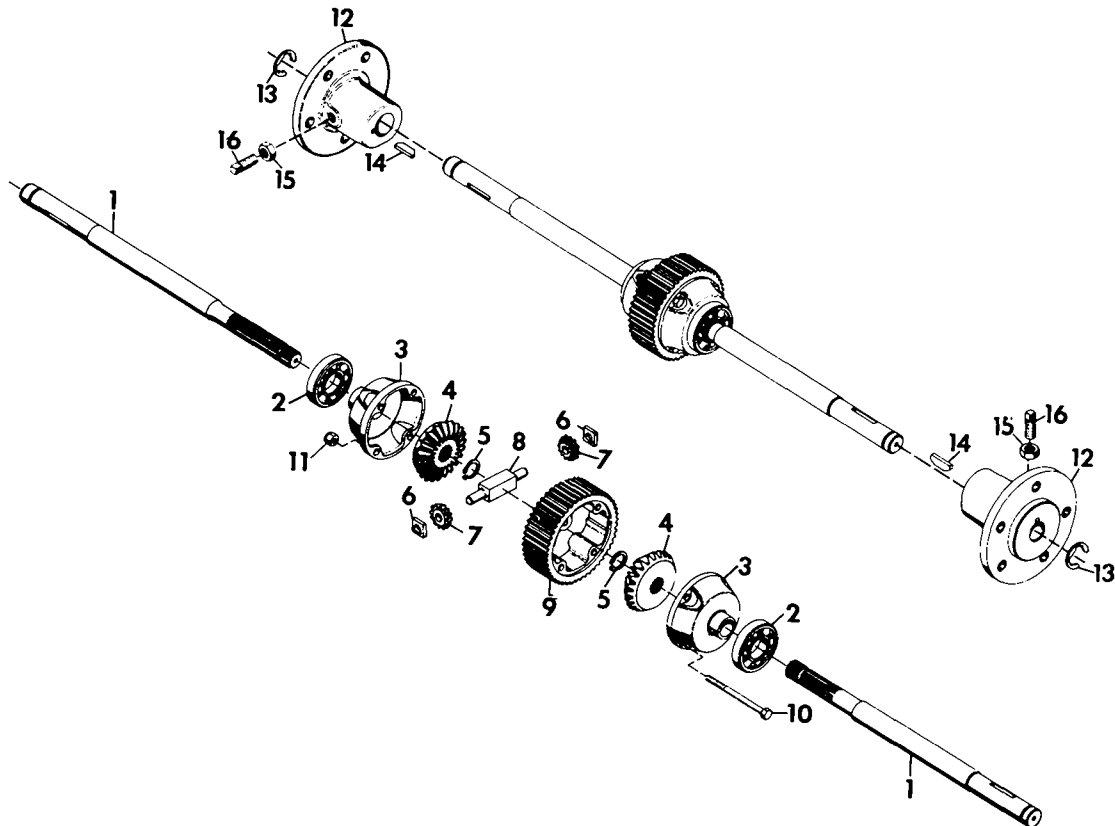

ITEM NO.	PART NO.	DESCRIPTION
1.	19957P1	Axle, Bevel Gear Differential
2.	17984P1	Bearing, Ball; 1.578 x 2.834 x .669
3.	19956P1	Cap, Differential End
4.	19953P1	Gear, Bevel; 6/8 DP, 22 Teeth x .800
5.	17980P1	Ring, Retaining
6.	12667P1	Block, Drive
7.	19952P1	Pinion, Bevel
8.	19954P1	Pin, Spider Pinion
9.	19953P1	Gear, Final Drive; 6.125 DP, 49 Teeth x 1.5
10.	20513P1	Bolt, Hex; 5/16-18 x 2 1/2
11.	20314P1	Nut, Hex; 5/16-18
12.	18052P1	Hub, Wheel
13.	18055P1	E-Ring
14.	187184	Key, Woodruff; .25 x 2.12, Soft
15.	124829	Nut, Jam; 7/8-16
16.	102897	Screw, Set; 1/8-16 x 1 1/4, SQ. HD. Cr. P. n

NUMBER 9 SHAFT, PTO CLUTCH ASSEMBLY

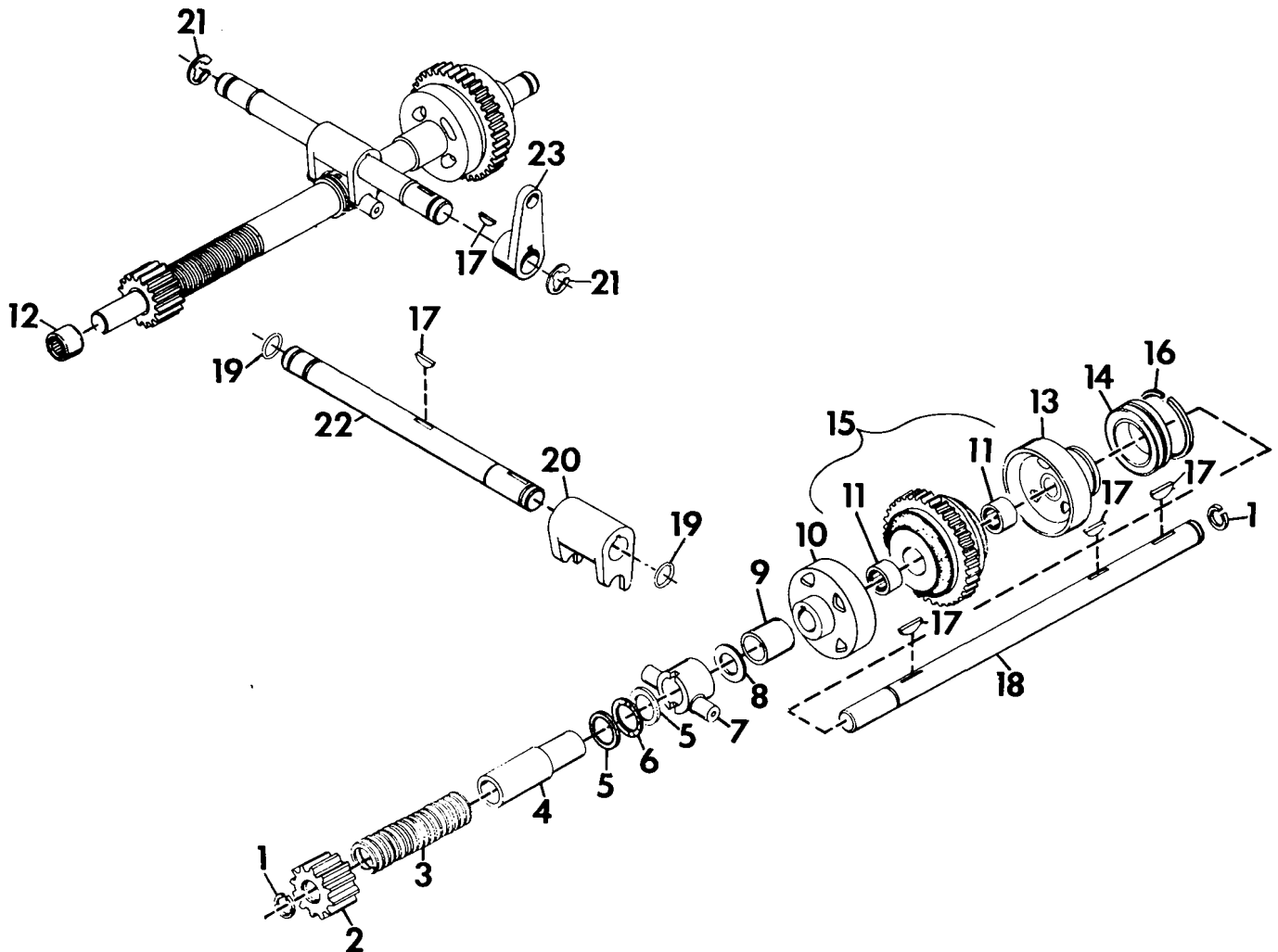

NUMBER 9 SHAFT, PTO CLUTCH ASSEMBLY

ITEM NO.	PART NO.	DESCRIPTION
1.	15733P1	Ring, Retaining
2.	17965P1	Gear, Spur PTO; 10 DP, 22 Teeth x 1.200 Standard
3.	17964P1	Spring, Compression; 5.0 x 1.50 x 200 Lb/in
4.	17963P1	Throw-Out, PTO
5.	17959P1	Race, Bearing Thrust; 1.002 x 1.552 x .090
6.	11225P1	Bearing, Needle Thrust; 1.002 x 1.552 x .078
7.	17960A1	Assembly, Shifting Collar
8.	14998P1	Race, Bearing Thrust; .752 x 1.240 x .090
9.	17958P1	Spacer, PTO
10.	17957P1	Cup, Clutch
11.	17949P1	Bearing, Needle; .750 x 1.000 x .500
12.	9660P1	Bearing, Needle; .750 x 1.000 x .500
13.	17952P1	Cup, Clutch
14.	17967P1	Bearing, Ball; 1.378 x 2.440 x .551
15.	17953A1	Assembly, Clutch Cone Bearing
16.	17966P1	Ring, Retaining; 1.375
17.	124549	Key, Woodruff; .187 x .750, Hard
18.	17951P1	Shaft, PTO Clutch
19.	18018P1	O-Ring; .625 x .750 x .062
20.	18016P1	Yoke, PTO
21.	11270P1	E-Ring
22.	18017P1	Shaft, PTO Yoke
23.	18019P1	Lever, PTO

NUMBER 10 SHAFT, PTO DRIVE ASSEMBLY

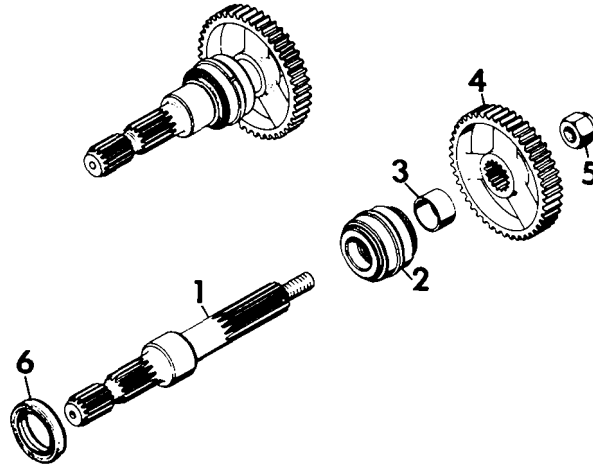

<u>ITEM NO.</u>	<u>PART NO.</u>	<u>DESCRIPTION</u>
1.	19538P1	Shaft, PTO
2.	14640A1	Assembly, Bearing; 1.000 x 1.980 x 1.243
3.	17924P1	Spacer; 1.060 x 1.250 x .450
4.	17922P1	Gear, Spur PTO; 10 DP, 56 Teeth x .750 Standard
5.	9414075	Nut, Lock; 5/8-11, Type N
6.	17923P1	Seal, Oil; 1.375 x 2.129 x .312

NUMBER 11, FORWARD - REVERSE CLUTCH ASSEMBLY

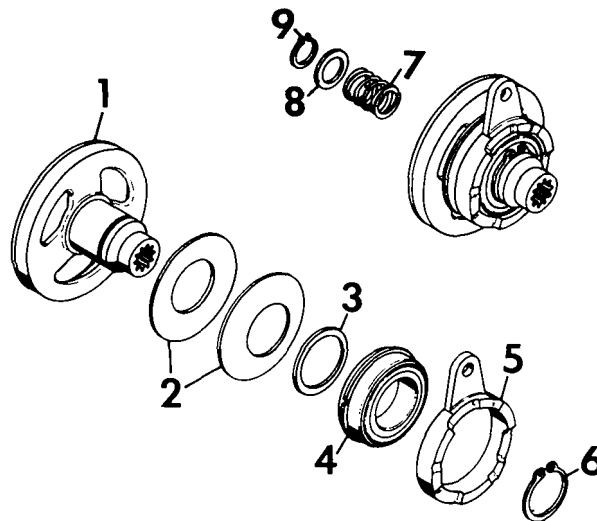

<u>ITEM NO.</u>	<u>PART NO.</u>	<u>DESCRIPTION</u>
1.	20449A1	Assembly, Clutch Disc
2.	18041P1	Spring, Belleville
3.	18548P1	Shim, FWD-REV Clutch; .030 Thick
4.	18042P1	Bearing, Ball; 1.574 x 3.149 x .708
5.	19063P1	Cam, Clutch
6.	18043P1	Ring, Retaining
7.	20444P1	Spring, Compression; .00 x .80 x 36 LB/in
8.	11223P1	Race, Bearing Thrust; 1.752 x 1.240 x .00
9.	11135P1	Ring, Retaining

NUMBER 12, TRANSMISSION CASE ASSEMBLY

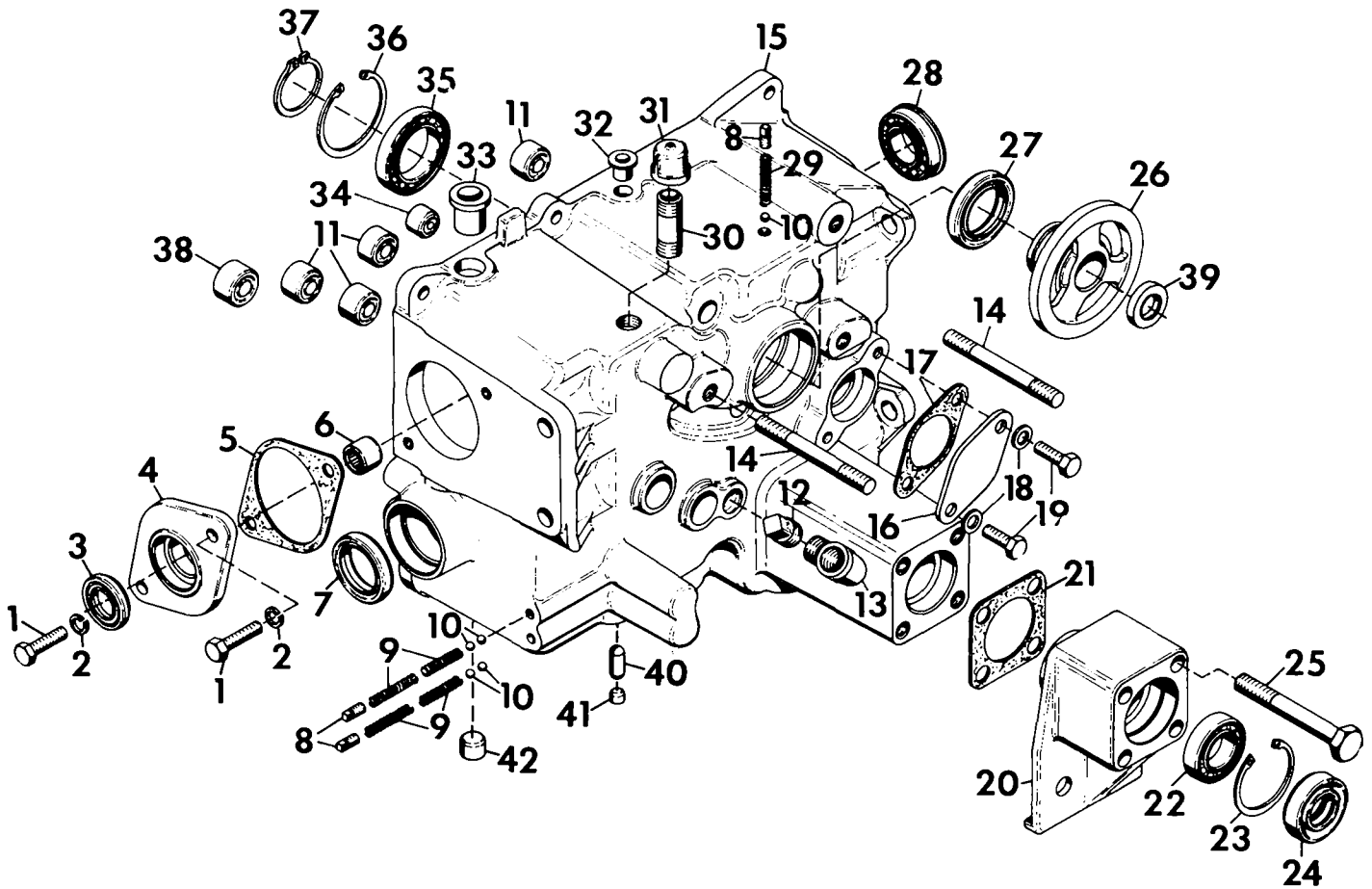

ITEM NO.	PART NO.	DESCRIPTION
1.	180079	Bolt, Hex; 5/16-18 x 1
2.	120214	Washer, Lock; 5/16 SP
3.	17975P1	Seal, Oil; .750 x 1.254 x .250
4.	18859P1	Cap, Front PTO
5.	18857P1	Gasket, Front Cap
6.	9660P1	Bearing, Needle; .750 x 1.00 x .500
7.	14640A1	Assembly, Bearing; 1.000 x 1.980 x 1.243
8.	103877	Plug, Pipe; 1/8 in. SQ. HD. Steel
9.	17936P1	Spring, Compression; 1.50 x .30 x 26 Lb/in
10.	274301	Ball, Steel; 5/16
11.	17915P1	Bearing, Needle; .750 x 1.0 x .750
12.	103880	Plug, Pipe; 1/2 in. SQ. HD. Steel
13.	108686	Elbow; 1/2, 90°, Street
14.	18036P1	Stud
15.	17911P1	Case, Transmission
16.	18421P1	Plate, Cover
17.	18422P1	Gasket, Cover Plate
18.	120394	Washer, Flat; .40 x .81 x .06
19.	180120	Bolt, Hex; 3/8-16 x 3/4
20.	18810P1	Retainer, Axle Bearing L.H.
21.	18030P1	Gasket
22.	18029P1	Bearing, Ball; 1.250 x 2.250 x .500
23.	18812P1	Ring, Retaining
24.	18031P1	Seal, Oil Axle; 1.250 x 2.254 x .500
25.	180191	Bolt, Hex; 1/2-13 x 3 1/4
26.	18024P1	Hub, Clutch
27.	17917P1	Seal, Oil; 2.250 x 1.378 x .435
28.	17967P1	Bearing, Ball; 1.378 x 2.440 x .551
29.	18015P1	Spring, Compression; 1.25 x .30 x 16 lb/in
30.	121664	Nipple, Pipe; 1/2 x 2.50
31.	19472P1	Cap, Pipe; 1/2 NPT
32.	17925P1	Bushing, 2-Speed
33.	17943P1	Bushing
34.	17914P1	Bearing, Needle; .62 x .81 x .75
35.	17915P1	Bearing, Ball; 1.968 x 3.149 x .629
36.	18872P1	Ring, Retaining
37.	17919P1	Ring, Retaining
38.	17912P1	Bearing, Needle; 1.0 x 1.25 x .75
39.	18035P1	Seal, Oil; .750 x 1.625 x .250
40.	18200P1	Pin, Interlock
41.	9421743	Lock, Cap
42.	17946P1	Hub, Clutch

NUMBER 13, TRANSMISSION COVER ASSEMBLY

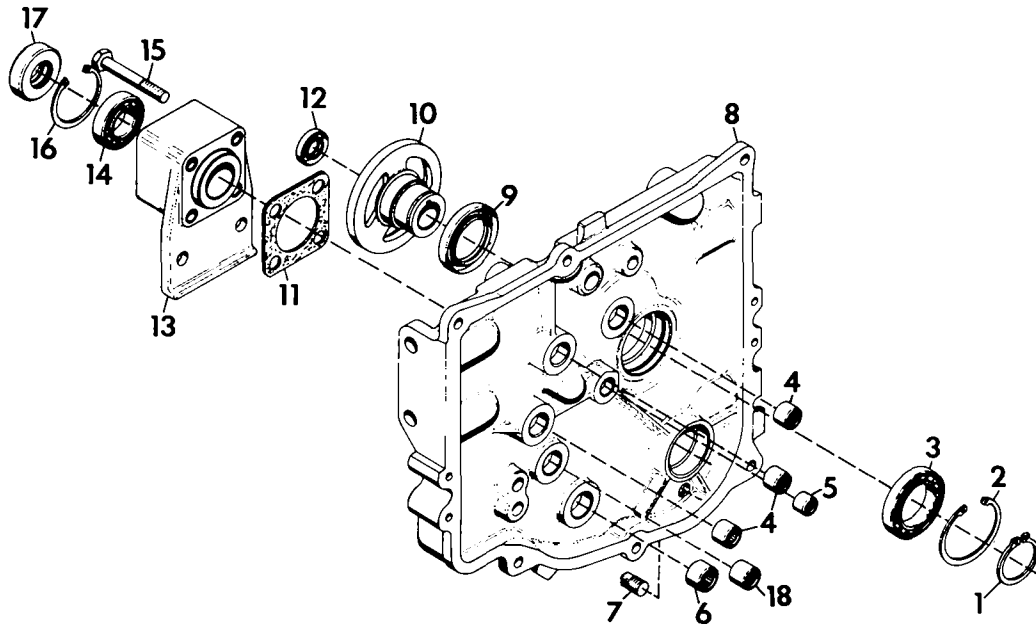

<u>ITEM NO.</u>	<u>PART NO.</u>	<u>DESCRIPTION</u>
1.	17919P1	Ring, Retaining
2.	18872P1	Ring, Retaining
3.	17915P1	Bearing, Ball; 1.968 x 1.378 x .433
4.	17913P1	Bearing, Needle; .750 x 1.00 x .750
5.	17914P1	Bearing, Needle; .62 x .81 x .75
6.	17912P1	Bearing, Needle; 1.0 x 1.25 x .75
7.	103879	Plug, Pipe; 3/8 in. SQ. HD. Steel
8.	18023P1	Cover, Transmission
9.	17917P1	Seal, Oil; 2.250 x 1.378 x .433
10.	18024P1	Hub, Clutch
11.	18030P1	Gasket
12.	18035P1	Seal, Oil; .750 x 1.625 x .250
13.	18810P1	Retainer, Axle Bearing L.H.
14.	18029P1	Bearing, Ball; 1.250 x 2.250 x .500
15.	180191	Bolt, Hex; 1/2-13 x 3 1/4
16.	18812P1	Ring, Retaining
17.	18031P1	Seal, Oil Axle; 1.250 x 2.254 x .500
18.	11063P1	Bearing, Needle; .75 x 1.00 x .75

MANUAL LIFT CONTROLS

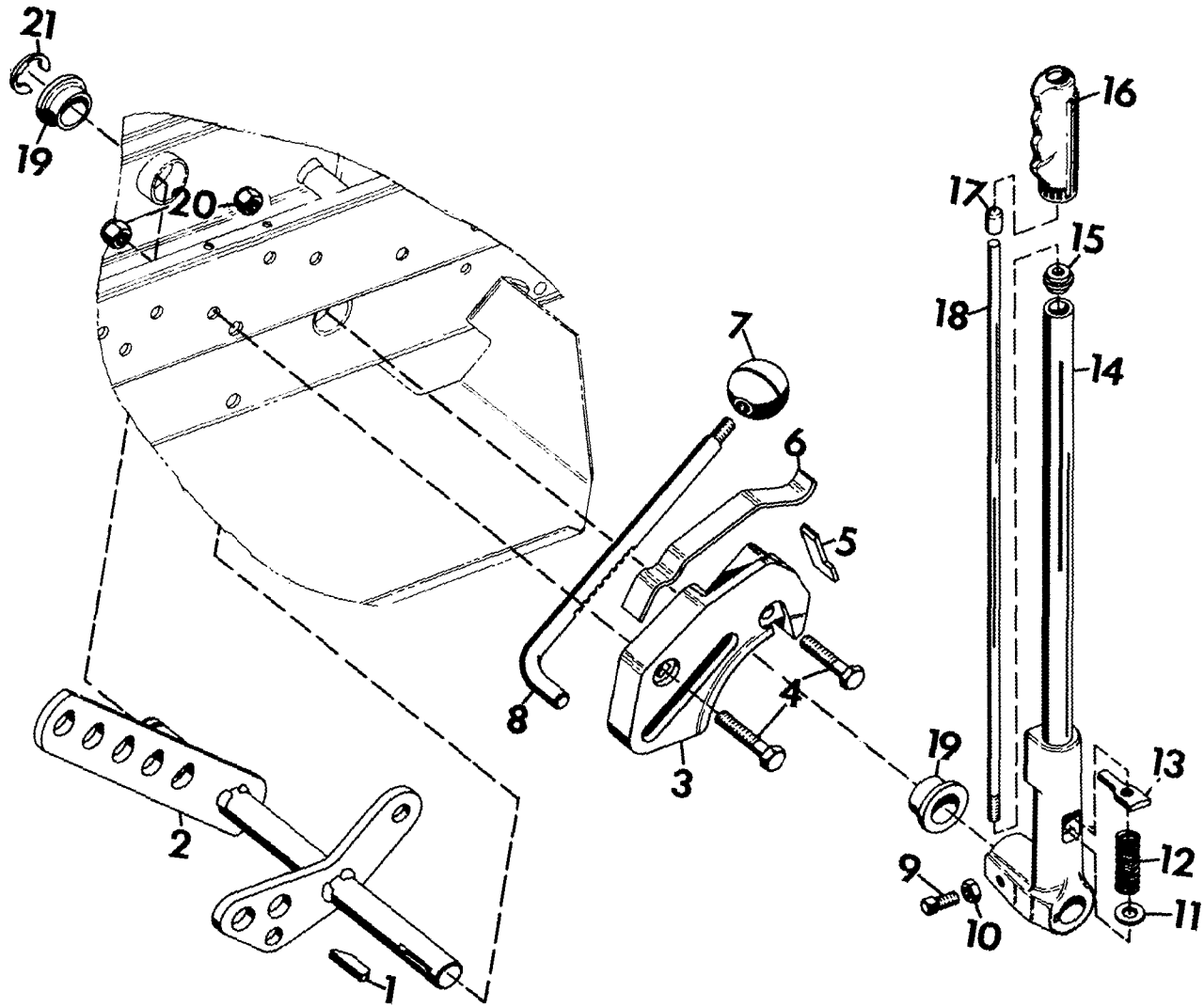

ITEM NO.	PART NO.	DESCRIPTION
1.	187184	Key, Woodruff; 1/4 x 2 1/8, Soft
2.	18404A1	Weldment, Lift Lever Shaft
3.	11103P1	Casting, Locator
4.	180124	Bolt, Hex; 3/8-16 x 1 1/4
5.	11106P1	Stop, Lever
6.	11105P1	Spring, Stop
7.	11297P1	Knob, Shift Lever
8.	18732P1	Rod, Lever Stop
9.	102896	Screw, Set; 3/8-16 x 1 SQ. HD.
10.	124829	Nut, Jamb; 3/8-16 Hex
11.	11670P1	Washer, Special Flat; .45 x .99 x .10
12.	10682P1	Spring, Compression; 2.0 x .72 x 15.5 Lb/in
13.	11116P1	Pawl, Lever
14.	11113A1	Assembly, Lift Lever
15.	11117P1	Guide, Push Rod
16.	11119P1	Grip, Flex
17.	19367P1	Tip, Push Rod
18.	11118P1	Rod, Lever Push
19.	11111P1	Bushing, Pivot
20.	456004	Nut, Lock; 3/8-16 Washer Insert
21.	11112P1	E-Ring

HYDRAULIC SYSTEM

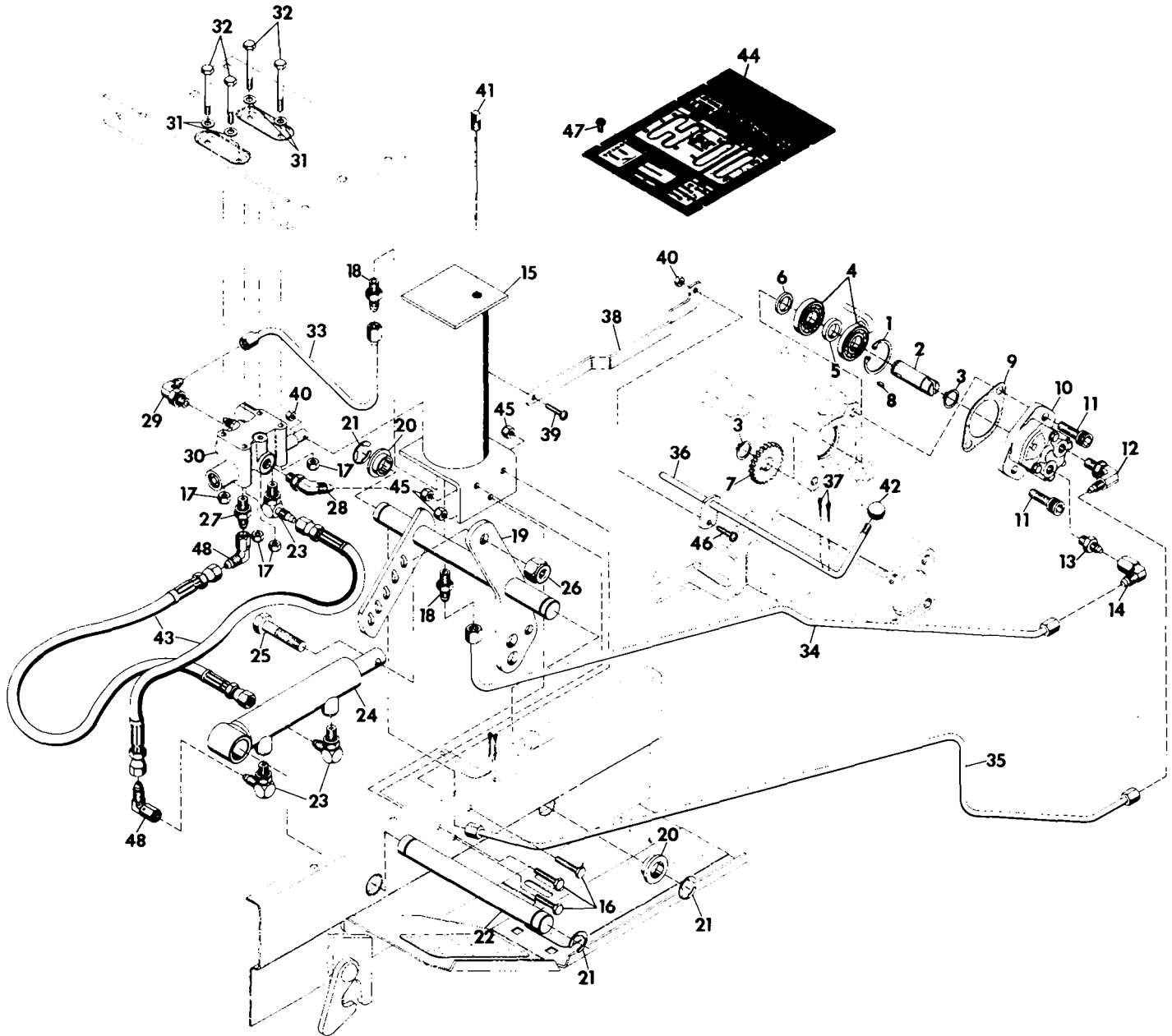

<u>ITEM NO.</u>	<u>PART NO.</u>	<u>DESCRIPTION</u>
1.	18799P1	Ring, Retaining
2.	18797P1	Shaft, Hyd. Pump
3.	18809P1	Ring, Retaining
4.	12626P1	Bearing, Ball; .590 x 1.378 x .433
5.	18807P1	Spacer; .620 x .750 x .588
6.	18798P1	Spacer; .620 x .750 x .364
7.	18808P1	Gear, Hyd. Pump
8.	271089	Key, Woodruff; 1/8 x 3/8, Hard
9.	18422P1	Gasket, Cover Plate
10.	18813P1	Pump, Hydraulic
11.	426370	Screw, Cap 3/8-16 x 1, Hex Socket HD.
12.	18816P1	Adapter, Hyd.; 3/4-16 STR.TH.D., 90° Elbow w/O-Ring
13.	18817P1	Adapter, Hyd.; 7/8-14 W/O-Ring, 9/16-14, STR.
14.	18818P1	Adapter, Hyd.; 9/16-18, Swivel 90° Elbow
15.	19161A1	Weldment, Hyd. Tank
16.	180122	Bolt, Hex; 3/8-16 x 1
17.	9419454	Nut, Lock; 1/4-20, Washer Insert
18.	19167P1	Adapter, Hyd.; 9/16-18 STR. TH.D. W/O-Ring
19.	18822A1	Weldment, Lift Lever Shaft
20.	11111P1	Bushing, Pivot
21.	11112P1	E-Ring
22.	18830P1	Shaft, Hyd. Cyl.
23.	18826P1	Adapter, Hyd.; 7/16-20 STR. TH.D., 90° Elbow W/O-Ring
24.	19471P1	Cylinder, Hydraulic
25.	180181	Bolt, Hex; 1/2-13 x 2
26.	435507	Nut, Lock; 1/2-13, Washer Insert
27.	21286P1	Adapter, Hyd.; 7/16-20 STR. TH.D. W/O-Ring
28.	18829P1	Adapter, Hyd.; 9/16-18 STR. TH.D. W/O-Ring, 45° Elbow
29.	18828P1	Adapter, Hyd.; 9/16-18 STR. TH.D. W/O-Ring, 90° Elbow
30.	18825P1	Valve, Hydraulic
31.	120392	Washer, Flat; 9/32 x 5/8 x .065
32.	180050	Bolt, Hex; 1/4-20 x 2 3/4
33.	19165P1	Line, Return; Valve To Tank
34.	19166P1	Line, Hyd.; (In) Tank To Pump
35.	18843P1	Line, Hyd.; (Out) Valve to Pump
36.	18833A1	Weldment, Hyd. Valve Rod
37.	121224	Pin, Cotter; 3/32 x 1
38.	18836P1	Rod, Hyd. Control
39.	132848	Screw, Machine; 10-24 x 1 Pan HD C-Recess
40.	190254	Nut, Lock; 10-24, Washer Insert
41.	19413A1	Stick, Hyd. Tank Dip
42.	11261P1	Knob, Adjusting Control
43.	18845P1	Hose, Hyd.; 14.5 in Long
44.	20955P1	Plate, Hydraulic Control Cover
45.	456004	Nut, Lock; 3/8-16, Washer Insert
46.	120910	Screw, Machine; 10-24 x 3/4, Pan HD. C-Recess
47.	167257	Screw, Self Tapping; 1/4-20 x 1/2 Pan HD., C-Recess
48.	21287P1	Adapter, Hyd.; 7/16-20 STR. TH.D., Swivel 90° Elbow

STEERING ASSEMBLY

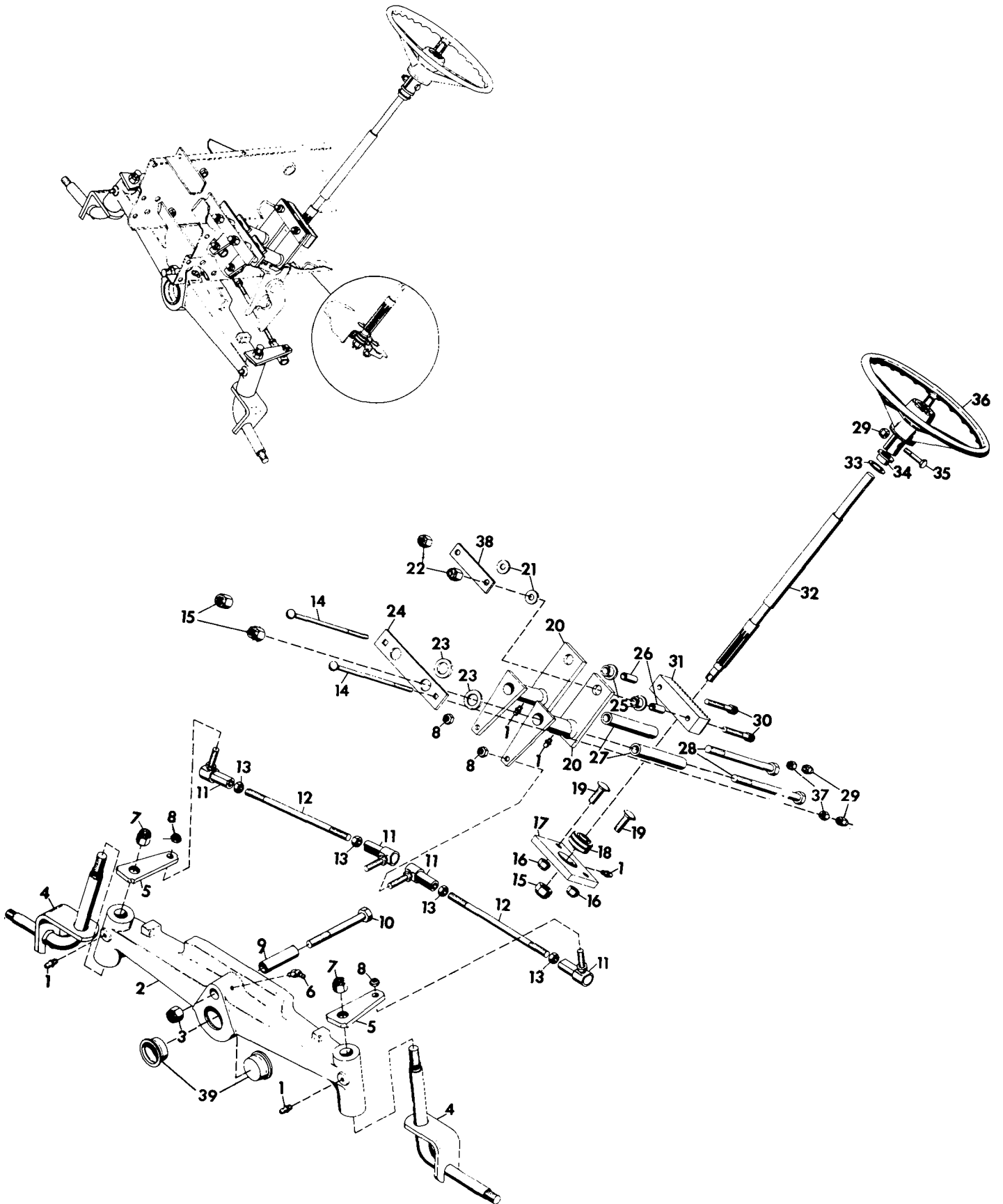

ITEM NO.	PART NO.	DESCRIPTION
1.	9411027	Fitting, Lube; 1/4-28
2.	23312	Axle Steering Assembly
3.	456007	Nut, Lock; 3/4-10, Washer Insert
4.	18463A1	Weldment, King Pin
5.	18461P1	Arm, Tie Rod
6.	9411031	Fitting, Lube; 1/4-28, 45 Deg. Elbow
7.	9414075	Nut, Lock; 5/8-11, Type N
8.	192481	Nut, Lock; 3/8-24, Washer Insert
9.	23237	Tube, Axle Pivot
10.	271781	Bolt, Hex; 3/4-10 x 4 1/2
11.	21084P1	Ball Joint, Steering
12.	21085P1	Rod, Steering Tie
13.	120369	Nut, Hex; 3/8-24
14.	126952	Bolt, 5/16-18 x 5 1/2, RD. HD. SQ. Neck
15.	435507	Nut, Lock; 1/2-13, Washer Insert
16.	9419456	Nut, Lock; 7/16-14, Washer Insert
17.	21148P1	Block, Bearing Support
18.	21147P1	Bearing, Spherical
19.	21146P1	Bolt, Bearing
20.	21071A1	Weldment, Steering Arm
21.	446470	Washer, Flat; 3/8 x 1 1/8 x .065
22.	456004	Nut, Lock; 3/8-16, Washer Insert
23.	14998P1	Race, Bearing Thrust; .752 x 1.240 x .092
24.	21079P1	Plate, Adjustment
25.	21077P1	Bearing, Flange; P/M Bronze
26.	21076P1	Bushing, Rack
27.	21078P1	Sleeve, Pivot
28.	443734	Bolt, Hex; 1/2-13 x 6
29.	9419455	Nut, Lock; 5/16-18, Washer Insert
30.	454473	Screw, Cap; 3/8-16 x 2, Hex Socket HD.
31.	21075P1	Gear, Rack
32.	21081P1	Column, Steering
33.	20273P1	Ring, Retaining; Internal Tooth
34.	10174P1	Bushing
35.	180082	Bolt, Hex; 5/16-18 x 1 3/8
36.	19448P1	Wheel, Steering
37.	120376	Nut, Hex; 5/16-18
38.	21246P1	Strap, Rack and Pinion
39.	18785P1	Cap, Front Axle

FRONT & REAR WHEEL ASM.

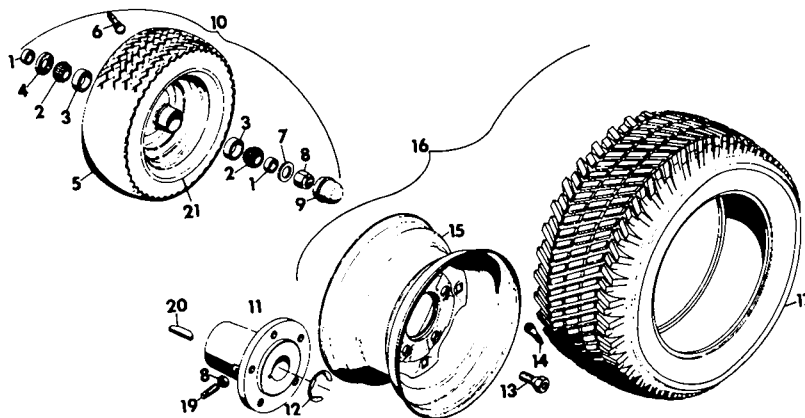

FRONT & REAR WHEEL ASSEMBLIES

ITEM NO.	PART NO.	DESCRIPTION
1.	18448P1	Spacer
2.	18446P1	Bearing, Cone
3.	18445P1	Bearing, Cup
4.	18447P1	Seal
5.	11190P1	Tire, Front; 16 x 6.50-8
6.	11191A1	Assembly, Valve Stem
7.	131016	Washer, Flat; 21/32 x 15/16 x .095
8.	9418692	Nut, Lock; 5/8-11 Washer Insert
9.	18449P1	Cap
10.	18442A1	Assembly, Front Wheel
11.	18052P1	Hub, Wheel
12.	18055P1	E-Ring
13.	12744P1	Bolts, Hub; 7/16-20 x 3/4, (Special)
14.	11191A1	Assembly, Valve Stem
15.	11195A1	Weldment, Rim
16.	11705A1	Assembly, Rear Wheel
17.	11194P1	Tire, Rear; 23 x 8.50-12
18.	124829	Nut, Jamb; 3/8-16 Hex
19.	102897	Screw, Set; 3/8-16 x 1 1/4 SQ. HD. Cup Point
20.	187184	Key Woodruff; 1/4 x 2 1/8, Soft
21.	18443P1	Rim, Front Wheel Assembly

TRANSMISSION & BRAKE CONTROLS

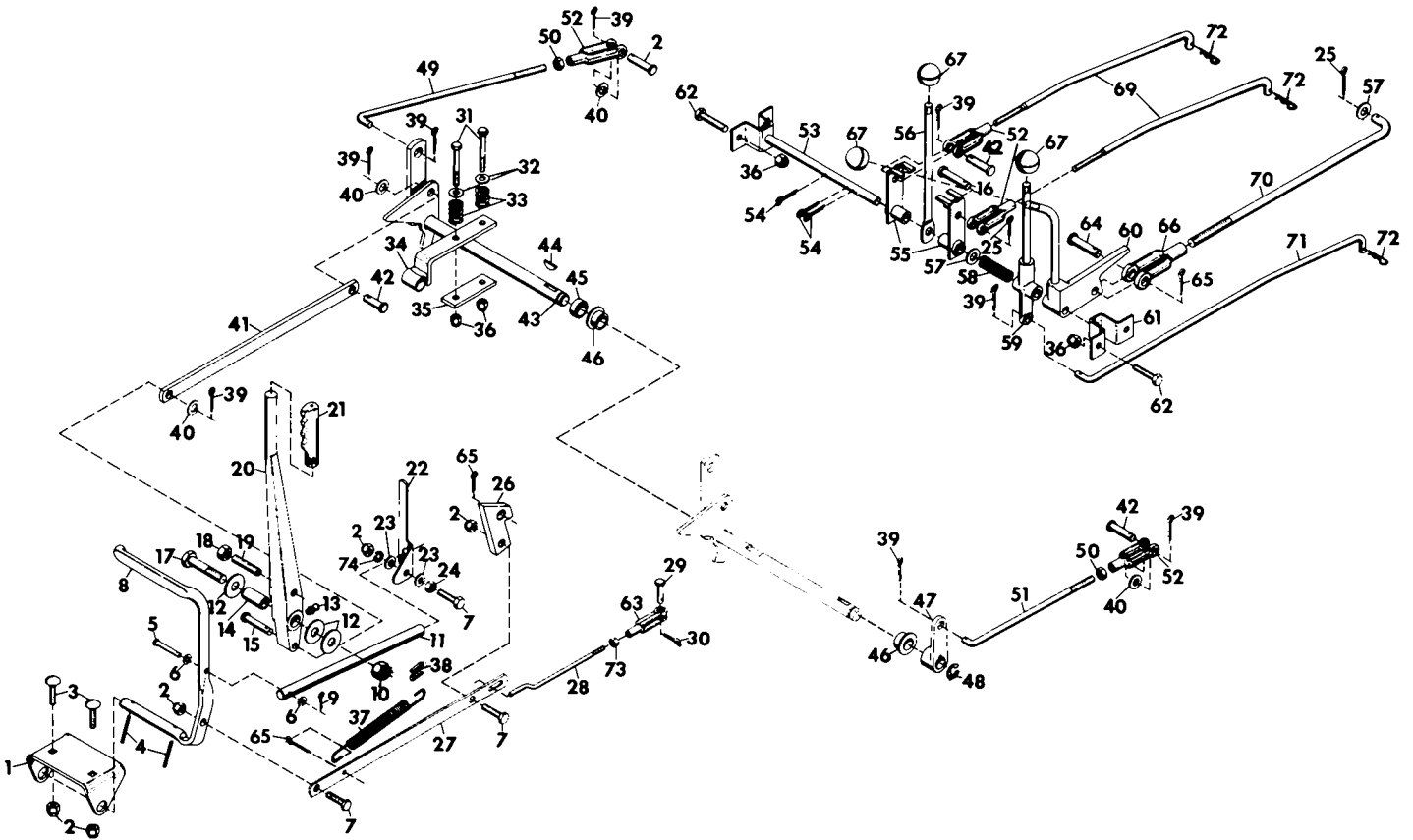
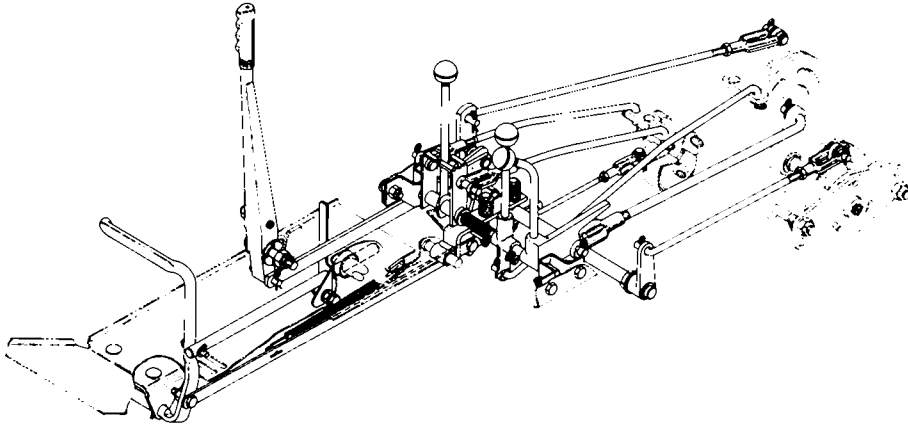

<u>ITEM NO.</u>	<u>PART NO.</u>	<u>DESCRIPTION</u>
1.	11021P1	Bracket, Brake Pedal
2.	456004	Nut, Lock; 3/8-16, Washer Insert
3.	126227	Bolt; 3/8-16 x 3/4, RD. HD. SQ. Neck
4.	454668	Pin, Spring; 3/16 x 1 1/4, CAD.
5.	9417923	Pin, Clevis; 1/4 x 1.5
6.	446179	Washer, Flat; 1/4 x 1/2 x .049
7.	180124	Bolt, Hex; 3/8-16 x 1 1/4
8.	11009P1	Pedal, R.H. Brake
9.	121223	Pin, Cotter; 1/16 x .75
10.	435507	Nut, Lock; 1/2-13, Washer Insert
11.	20773P1	Rod, Parking Brake
12.	120390	Washer, Flat; 9/16 x 1 3/8 x .109
13.	9411027	Fitting, Lube; 1/4-28
14.	11074P1	Bushing, FWD-REV Lever; .505 x .749 x 1.438
15.	9415571	Pin, Clevis; 3/8 x 1.531
16.	10672P1	Pin, Clevis; 3/8 x 1.250
17.	180188	Bolt, Hex; 1/2-13 x 2 3/4
18.	120238	Nut, Jamb; 1/2-13
19.	102623	Screw, Set; 1/2-13 x 2, Cup PT.
20.	19062P1	Lever, FWD-REV
21.	11078P1	Grip, FWD-REV Lever
22.	20772P1	Bracket, Parking Brake
23.	20775P1	Washer, Nylon
24.	124829	Nut, Jamb; 3/8-16
25.	179128	Pin, Cotter; 1/4 x 1
26.	18381P1	Cam, Brake
27.	21131P1	Link, Front
28.	21132P1	Link, Rear
29.	138083	Pin, Clevis; 1/4 x .766
30.	9423302	Pin, Cotter; 5/64 x 5/8
31.	180091	Bolt, Hex; 5/16-18 x 2 1/2
32.	120393	Washer, Flat; 11/32 x 11/16 x .065
33.	11779P1	Spring, Compression; 1 x .78 x 338 Lb/in
34.	18396A1	Weldment, Clutch Shaft Bracket
35.	18464P1	Plate
36.	9419455	Nut, Lock; 5/16-18, Washer Insert
37.	11263P1	Spring, Extension; 5.5 x .50 x 20 Lb/in
38.	11329P1	Spring, Clip
39.	121222	Pin, Cotter; 3/32 x .75
40.	120394	Washer, Flat; 13/32 x 13/16 x .065
41.	18403P1	Link, FWD-REV Shifter
42.	138078	Pin, Clevis; 3/8 x .948
43.	18390A1	Weldment, Clutch Shaft
44.	124552	Key, Woodruff; 3/16 x 1, Hard
45.	18485P1	Spacer, Clutch Shaft; .760 x 1.00 x .540
46.	10174P1	Bushing, Control Shaft
47.	18395P1	Arm, Rev Clutch
48.	11270P1	E-Ring
49.	18400P1	Rod, FWD. Clutch
50.	124925	Nut, Jamb; 3/8-24
51.	18401P1	Rod, REV Clutch
52.	18380P1	Clevis, Adjustable; 3/8-24
53.	18365A1	Weldment, Cross Shaft
54.	137185	Pin, Cotter; 1/8 x 1
55.	18368A1	Weldment, Shifter Arm
56.	18371P1	Lever, Shifter
57.	120396	Washer, Flat; 17/32 x 1 1/16 x .095
58.	18372P1	Spring, Compression; 2 3/4 x .625 x 34 Lb/in
59.	18373A1	Assembly, 2-Speed Control
60.	20662A1	Assembly, PTO Control
61.	11096P1	Bracket, Cross Shaft
62.	180077	Bolt, Hex; 5/16-18 x 3/4
63.	104036	Clevis, Adjustable; 1/4-28
64.	138086	Pin, Clevis; 1/2 x 1.213
65.	177923	Pin, Cotter; 1/8 x 3/4
66.	18387P1	Clevis, Adjustable; 1/2-20
67.	10670P1	Knob, 2-Speed Control
69.	18389P1	Rod, Shifting
70.	18386P1	Rod, PTO
71.	18388P1	Rod, 2-Speed
72.	11860P1	Cotter, Hair Pin
73.	120367	Nut, Hex; 1/4-28
74.	120382	Washer, Lock; 3/8 SP

TRACTOR FRAME ASSEMBLY

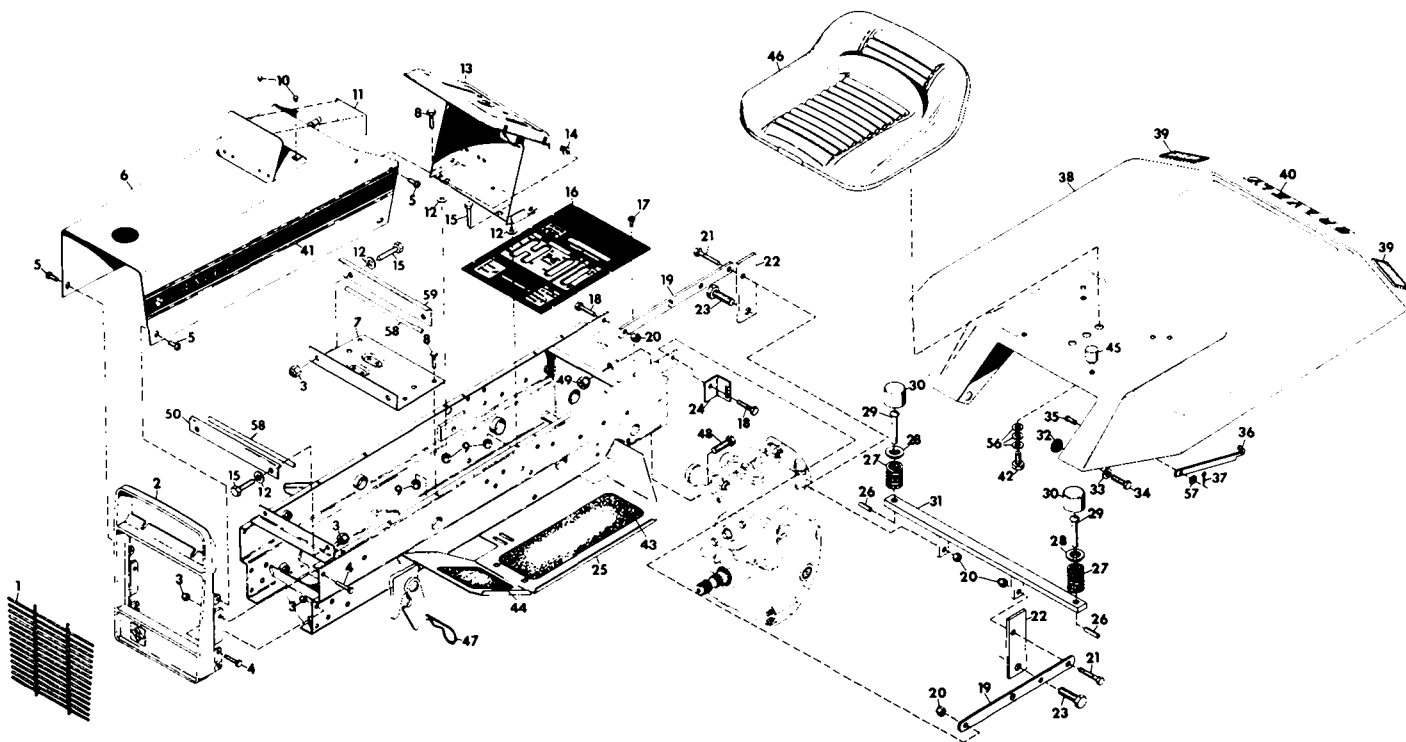
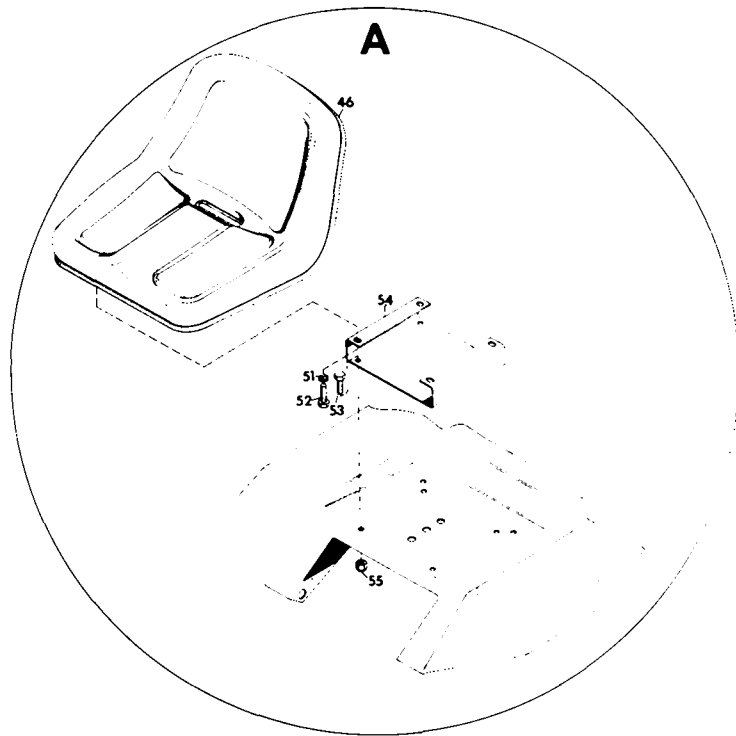

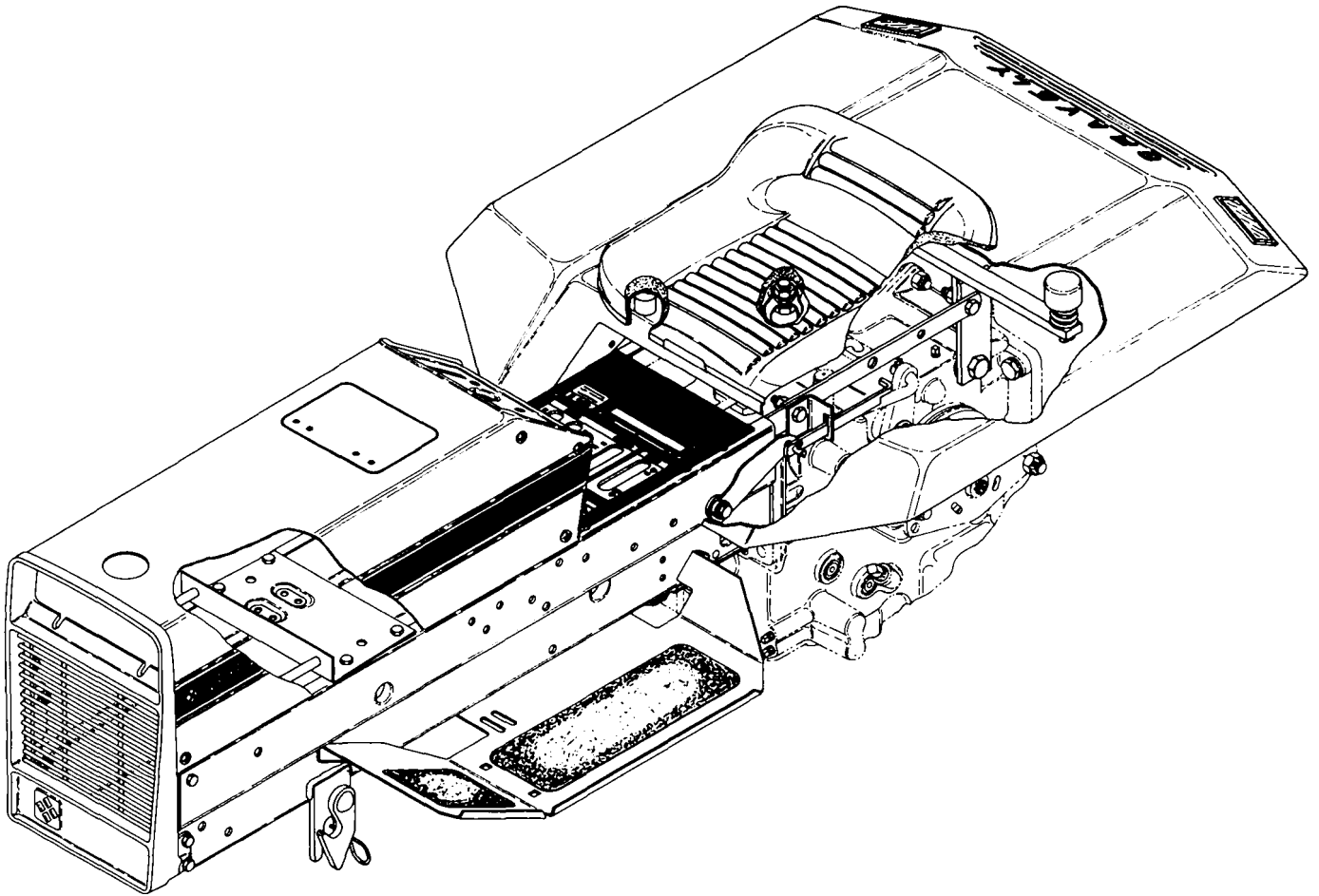

ITEM NO.	PART NO.	DESCRIPTION	ITEM NO.	PART NO.	DESCRIPTION
1	11057	Insert, Mesh Grille	37	121223	Pin, Cotter; .062 x .750
2	10969	Casting, Grille	38	19070	Weldment, Rear Fender; 810, 812, 816S
3	419455	Nut, Lock; 5/16-18 Washer Insert		23297	Weldment, Rear Fender; 816T,
4	180079	Bolt, Hex; 5/16-18 x 1	39	17837	Reflector, Red Safety
5	160515	Screw, Machine; 1/4-20 x .500 Pan Hd C-Recess	40	10509	Decal, Gravely Black Vinyl; 810, 812, 816S
6	15707	Assembly, Hood	41	19509	Decal, 810 L.H.
7	18573	Tray, Battery		19510	Decal, 812 L.H.
8	180018	Bolt, Hex; 1/4-20 x .625		20553	Decal, 816S L.H.
9	419454	Nut, Lock; 1/4-20 Washer Insert		23274	Decal, 816T L.H.
10	18197	Plug, Bumper		23306	Decal, 818T L.H.
11	11989	Decal, Electrical System Warning	NS	19495	Decal, 810 R.H.
12	120392	Washer, Flat; .281 x .625 x .065	NS	19496	Decal, 812 R.H.
13	23307	Weldment, Instrument Panel; 816T, 818T	NS	20554	Decal, 816S R.H.
	21455	Weldment, Instrument Panel; 810, 812, 816S	NS	23275	Decal, 816T R.H.
14	11777	Grommet, Plastic	NS	23305	Decal, 818T R.H.
15	180020	Bolt, Hex; 1/4-20 x .750	42	180171	Bolt, Hex; 1/2-13 x .750
16	20953	Plate, Manual Control Cover	43	11653	Cover, Large Footboard
	20955	Plate, Hydraulic Control Cover	44	11654	Cover, Small Footboard
17	167257	Screw, Tapping; 1/4-20 x .500 Pan Hd C-Recess	45	11352	Bumper, Stem
18	180124	Bolt, Hex; 3/8-16 x 1.250	46	21424	Seat, 810, 812, 816S
19	18361	Strap, Frame Extension		21423	Seat, 816T, 818T
20	456004	Nut, Lock; 3/8-16 Washer Insert	47	10405	Cotter, Hair Pin
21	180126	Bolt, Hex; 3/8-16 x 1.500	48	181700	Bolt, Hex; 1/2-20 x 1.500
22	19491	Support, Standard Deck	49	11085	Nut, Rim
23	180173	Bolt, Hex; 1/2-13 x 1.000	50	22421	Bracket, Forward Tank
24	18362	Bracket, Fender Hold-Up	51	120214	Washer, Lock; 5/16 SP
25	21089	Weldment, Main Frame	52	180075	Bolt, Hex; 5/16-18 x .625
26	454666	Pin, Spring; .125 x .500	53	180077	Bolt, Hex; 5/16-18 x .750
27	11307	Spring, Compression; 1.640 x .97 x 117 Lb/in	54	21422	Support, Seat
28	5741	Cap, Valve Spring	55	413447	Nut, Lock; 5/16-18 Type N
29	11308	Pin, Spring Mounting	56	120396	Washer, Flat; .500 x 1.062 x .095
30	11768	Tip, Rubber	57	446179	Washer, Flat; .250 x .500 x .049
31	18358	Weldment, Fender Support	58	14897	Moulding
32	11138	Bushing, Rear Fender	59	22422	Bracket, Rear Tank
33	120394	Washer, Flat; .406 x .812 x .065			
34	180122	Bolt, Hex; 3/8-16 x 1.0			
35	417923	Pin, Clevis; .250 x 1.500			
36	18416	Strap, Fender Hold-Up			

NOTE: Circle "A" Pertains to the 816T & 818T Tractors Only

REAR HITCH 810, 812 & 816S

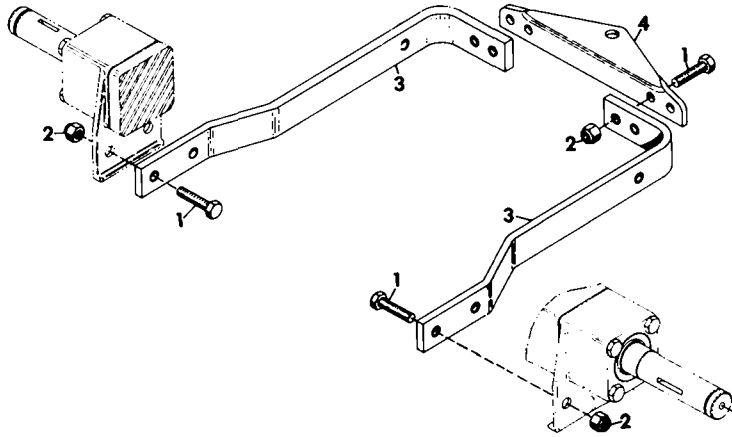

ITEM NO.	PART NO.	DESCRIPTION
1.	180179	Bolt, Hex; 1/2-13 x 1 3/4
2.	435507	Nut, Lock; 1/2-13 Washer Insert
3.	70450P1	Arm, Rear Hitch
4.	19517P1	Plate, Hitch

REAR HITCH — 816T & 818T

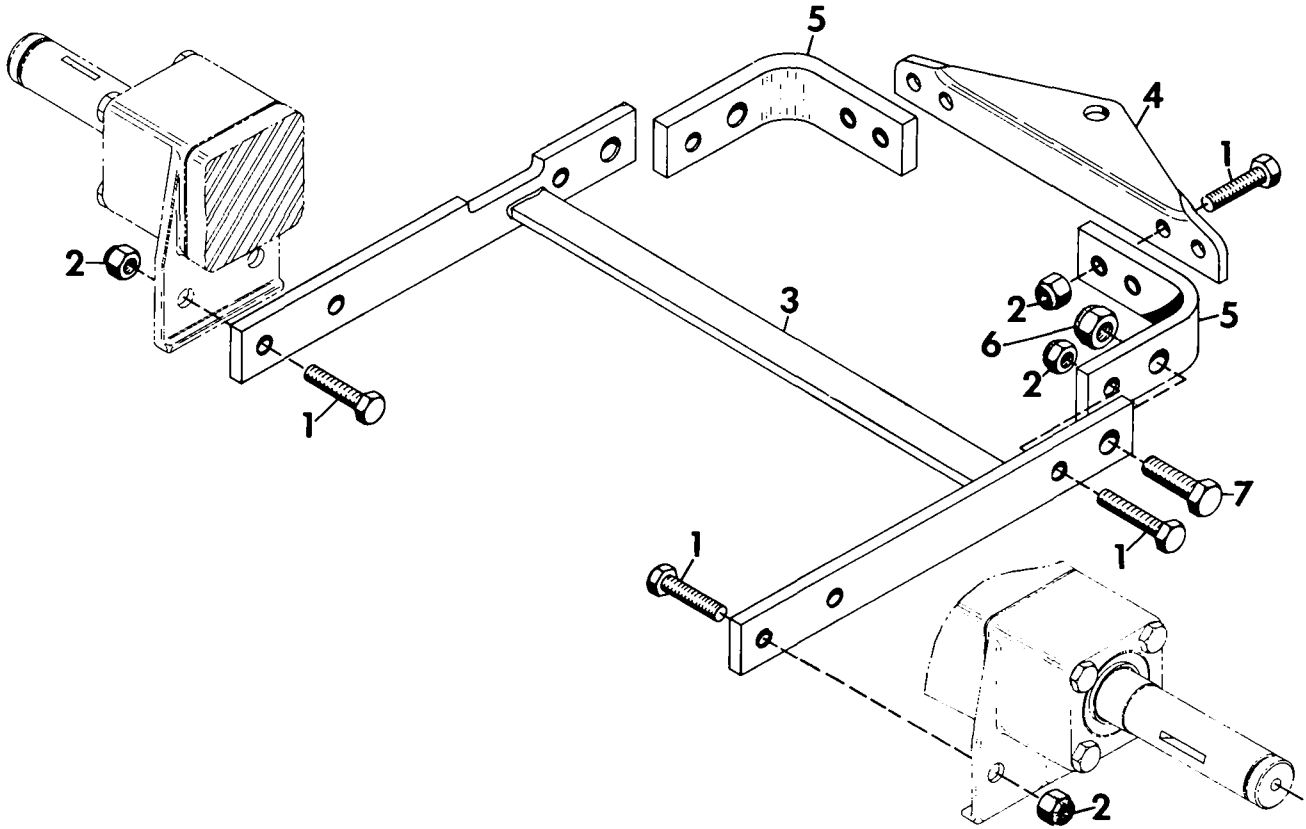

ITEM NO.	PART NO.	DESCRIPTION
1.	180179	Bolt, Hex; 1/2-13 x 1 3/4
2.	435507	Nut, Lock; 1/2-13 Washer Insert
3.	21421A1	Weldment, Draw Bar
4.	19517P1	Plate, Hitch
5.	21418P1	Bracket, Hitch Plate
6.	414075	Nut, Lock 5/8-11 Type
7.	271723	Bolt, Hex 5/8-11 x 2

FUEL, ENGINE & EXHAUST SYSTEM

810 & 812

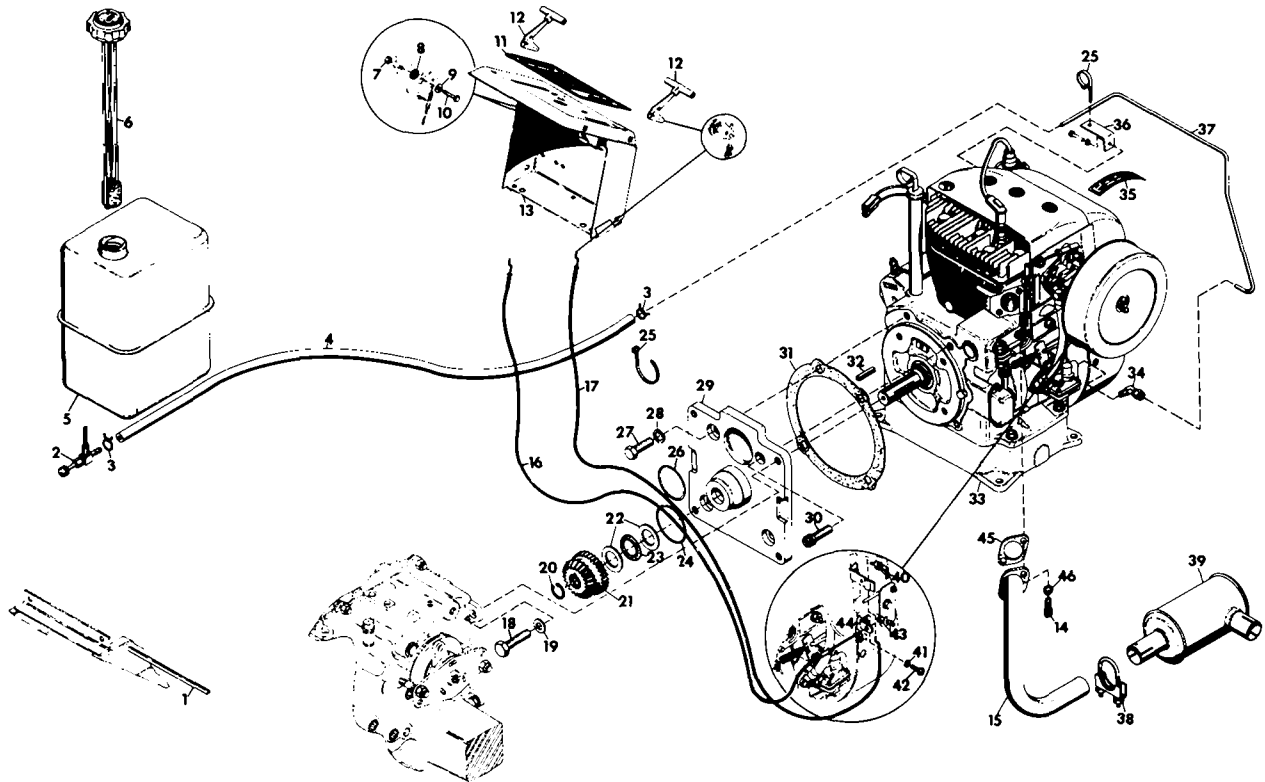

ITEM NO.	PART NO.	DESCRIPTION
1.	14897P1	Moulding
2.	18563P1	Valve, Fuel; 90 Deg., Reverse Flow
3.	7216P1	Clamp, Fuel Hose
4.	21482P1	Hose, Fuel
5.	12383P1	Tank, Fuel
6.	21415P1	Gauge, Gas
7.	9411621	Nut, Lock; 1/4-28 Plug Insert
8.	11772P1	Washer, Friction
9.	11774P1	Washer, Spring
10.	181566	Bolt, Hex; 1/4-28 x 3/4
11.	21417P1	Decal, Instrument Panel
12.	11773A1	Assembly, Knob and Lever
13.	21455A1	Weldment, Instrument Panel; (810, 812, 816S)
14.	9421705	Screw, Cap; 5/16-18 x 3/4, Socket HD.
15.	19492P1	Header, Exhaust
16.	18509A1	Assembly, Throttle Control Conduit
17.	11771A1	Assembly, Choke Control Conduit
18.	180175	Bolt, Hex; 1/2-13 x 1 1/4
19.	120396	Washer, Flat; 17/32 x 1 1/16 x .095
20.	18344P1	Ring, Retaining; Internal
21.	18343P1	Gear, Spur and Bevel Input
22.	18342P1	Race, Bearing Thrust; 1.127 x 1.740 x .060
23.	18341P1	Bearing, Thrust; 1.127 x 1.740 x .078
24.	18346P1	O-Ring; 3 x 3 3/16 x 3/32
25.	10629P1	Tie, Cable
26.	18347P1	O-Ring; 2 1/2 x 2 3/4 x 1/8
27.	180146	Bolt, Hex; 7/16-14 x 1 1/8
28.	131100	Washer, Lock; 7/16 SP, Heavy
29.	20555P1	Adaptor, Engine
30.	9421648	Screw, Cap; 7/16-14 x 1, Socket HD.
31.	18340P1	Gasket, Adaptor
32.	18345P1	Key, Square; 1/4 x 1 1/4
33.	21167A1	Engine, 10 HP; Kohler
	19482A1	Engine, 12 HP; Kohler
34.	114798	Assembly, 1/4 Ball Sleeve Elbow
35.	10862P2	Decal, Air Cleaner Instruction
36.	12019P1	Bracket, Fuel Line Support
37.	12009P1	Connector, Pump to Fuel Line
38.	14728P1	Clamp, Muffler
39.	18543P1	Muffler, Exhaust
40.	7331P1	Clip, Speed
41.	120380	Washer, Lock; 1/4 SP
42.	160515	Screw, Machine; 1/4-20 x 1/2, Pan HD.
43.	120375	Nut, Hex; 1/4-20
44.	18522P1	Bracket, Throttle Control
45.	11202P1	Gasket, Exhaust
46.	120214	Washer, Lock 5/16 S

FUEL, ENGINE & EXHAUST SYSTEM 816S

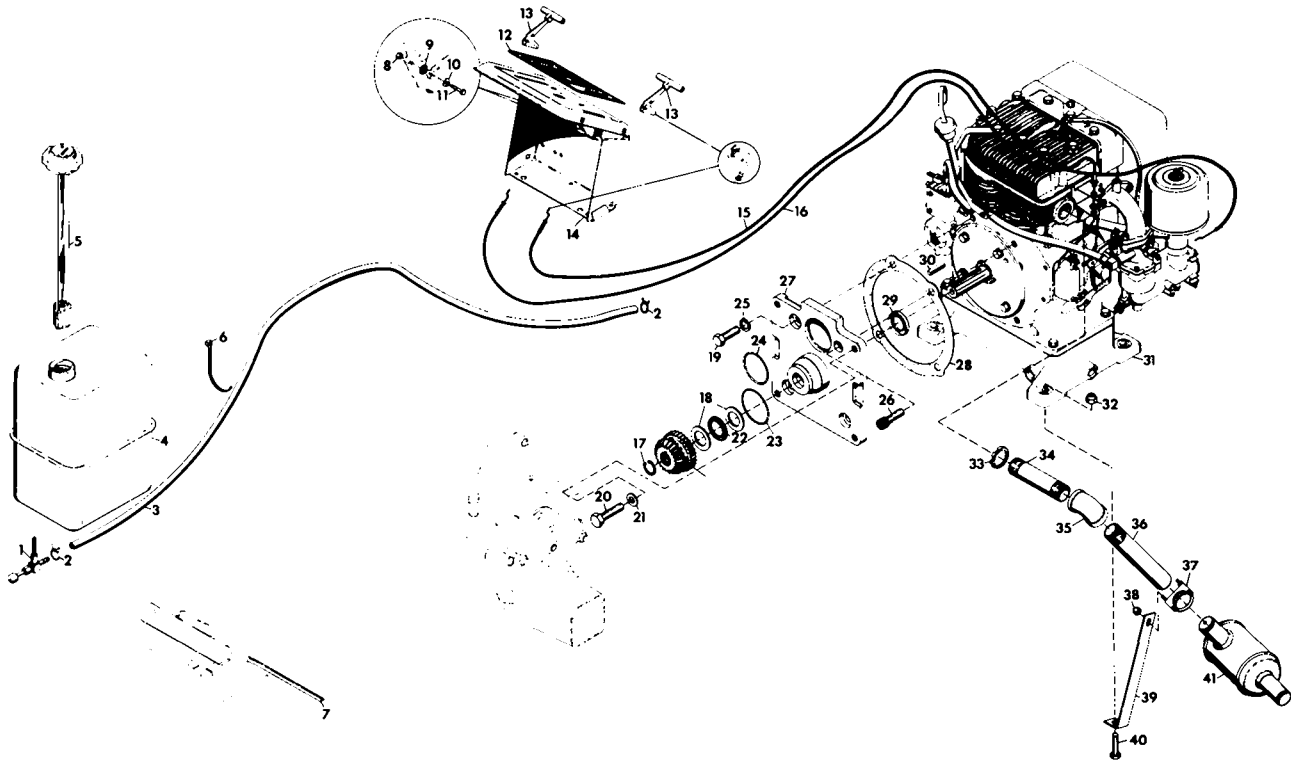

ITEM NO.	PART NO.	DESCRIPTION
1.	18563P1	Valve, Fuel; 90 Deg., Reverse Flow
2.	7216P1	Clamp, Fuel Hose
3.	20560P1	Hose, Fuel
4.	12383P1	Tank, Fuel
5.	21415P1	Gauge, Gas
6.	10629P1	Tie, Cable
7.	14897P1	Moulding
8.	9411621	Nut, Lock; 1/4-28 Plug Insert
9.	11772P1	Washer, Friction
10.	11774P1	Washer, Spring
11.	181566	Bolt, Hex; 1/4-28 x 3/4
12.	21417P1	Decal, Instrument Panel
13.	11773A1	Assembly, Knob and Lever
14.	21455A1	Weldment, Instrument Panel;(810, 812, 816S)
15.	20565A1	Assembly, Conduit Choke
16.	20942A1	Assembly, Conduit Throttle
17.	18344P1	Ring, Retaining; Internal
18.	18342P1	Race, Bearing Thrust; 1.127 x 1.740 x .060
19.	180146	Bolt, Hex; 7/16-14 x 1 1/8
20.	180175	Bolt, Hex; 1/2-13 x 1 1/4
21.	120396	Washer, Flat; 17/32 x 1 1/16 x .095
22.	18341P1	Bearing, Thrust; 1.127 x 1.740 x .078
23.	18346P1	O-Ring; 3 x 3 3/16 x 3/32
24.	18347P1	O-Ring; 2 1/2 x 2 3/4 x 1/8
25.	131100	Washer, Lock; 7/16 SP, Heavy
26.	9421648	Screw, Cap; 7/16-14 x 1, Socket HD.
27.	20555P1	Adaptor, Engine
28.	18340P1	Gasket, Adaptor
29.	18343P1	Gear, Spur and Bevel Input
30.	18345P1	Key, Square; 1/4 x 1 1/4
31.		Engine, 16 HP; B & S
32.	456004	Nut, Lock; 3/8-16, Washer Insert
33.	10866P1	Nut, Conduit; 1 in Pipe
34.	20579P1	Pipe, Exhaust; 1 in x 6 in
35.	127793	Elbow, Pipe; 90 Deg., 1 in
36.	20580P1	Pipe, Exhaust; 1 in x 8.4 in
37.	14728P1	Clamp, Muffler
38.	120368	Nut, Hex; 5/16-24
39.	20581P1	Support, Exhaust
40.	180124	Bolt, Hex; 3/8-14 x 1 1/4
41.	18543P1	Muffler, Exhaust

FUEL, ENGINE & EXHAUST SYSTEM 816T & 818T

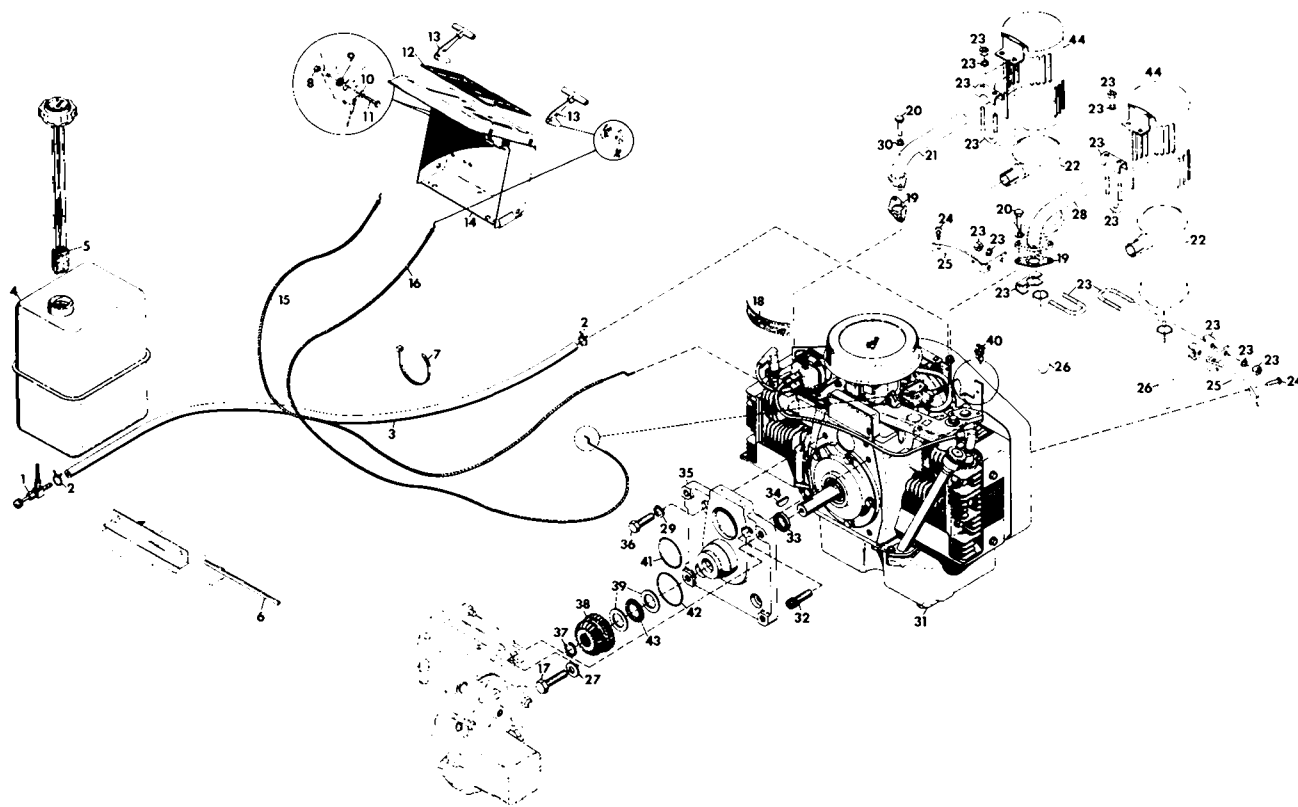

ITEM NO.	PART NO.	DESCRIPTION
1	18563	Valve, Fuel; 90 Deg Rev. Flow
2	7216	Clamp, Fuel Hose
3	10896	Line, Fuel
4	12383	Tank, Fuel
5	21415	Gauge, Gas
6	14897	Moulding
7	10629	Tie, Cable
8	411621	Nut, Lock; 1/4-28 Plug Insert
9	11772	Washer, Friction
10	11774	Washer, Spring
11	181556	Bolt, Hex; 1/4-28 x .750
12	12011	Decal, Instrument Panel
13	11773	Assembly, Knob & Lever
14	21432	Weldment, Instrument Panel
15	20942	Assembly, Throttle Conduit
16	20565	Assembly, Choke Conduit
17	180177	Bolt, Hex; 1/2-13 x 1.500
18	10862	Decal, Air Cleaner Instructions
19	23290	Gasket, Onan Exhaust
20	421705	Screw, Cap; 5/16-18 x .750 Socket Hd.
21	23279	Weldment, Exhaust Header R.H.
22	23299	Muffler
23	14728	Clamp, Muffler
24	144811	Screw, Tapping; 10-12 x .500 Pan Hd C-Recess
25	23280	Bracket, Muffler
26	23301	Extension, Muffler
27	120396	Washer, Flat; .500 x 1.062 x .095
28	23277	Weldment, Exhaust Header L.H.
29	120382	Washer, Lock; 3/8 SP
30	120214	Washer, Lock; 5/16 SP
31		Engine, Onan; 18 HP Engine, Onan; 16 HP
32	454475	Screw, Cap; 3/8-16 x 1.750 Hex Soc Hd
33	18517	Seal, Oil; 1.125 x 1.628 x .250
34	103909	Key, Woodruff; .250 x 1.125 Soft
35	18427	Adapter, Engine; Onan
36	180128	Bolt, Hex; 3/8-16 x 1.750
37	18344	Ring, Retaining; 1.125 Bore
38	18348	Gear, Input Spur and Bevel
39	18342	Race, Bearing Thrust; 1.127 x 1.740 x .060
40	7331	Clip, Speed
41	18347	O-Ring; 2.500 x 2.750 x .125
42	18346	O-Ring; 3.000 x 3.188 x .094
43	18341	Bearing, Hrs; 1.127 x 1.740 x .078
44	23300	Shield, Muffler

ELECTRICAL SYSTEM 810

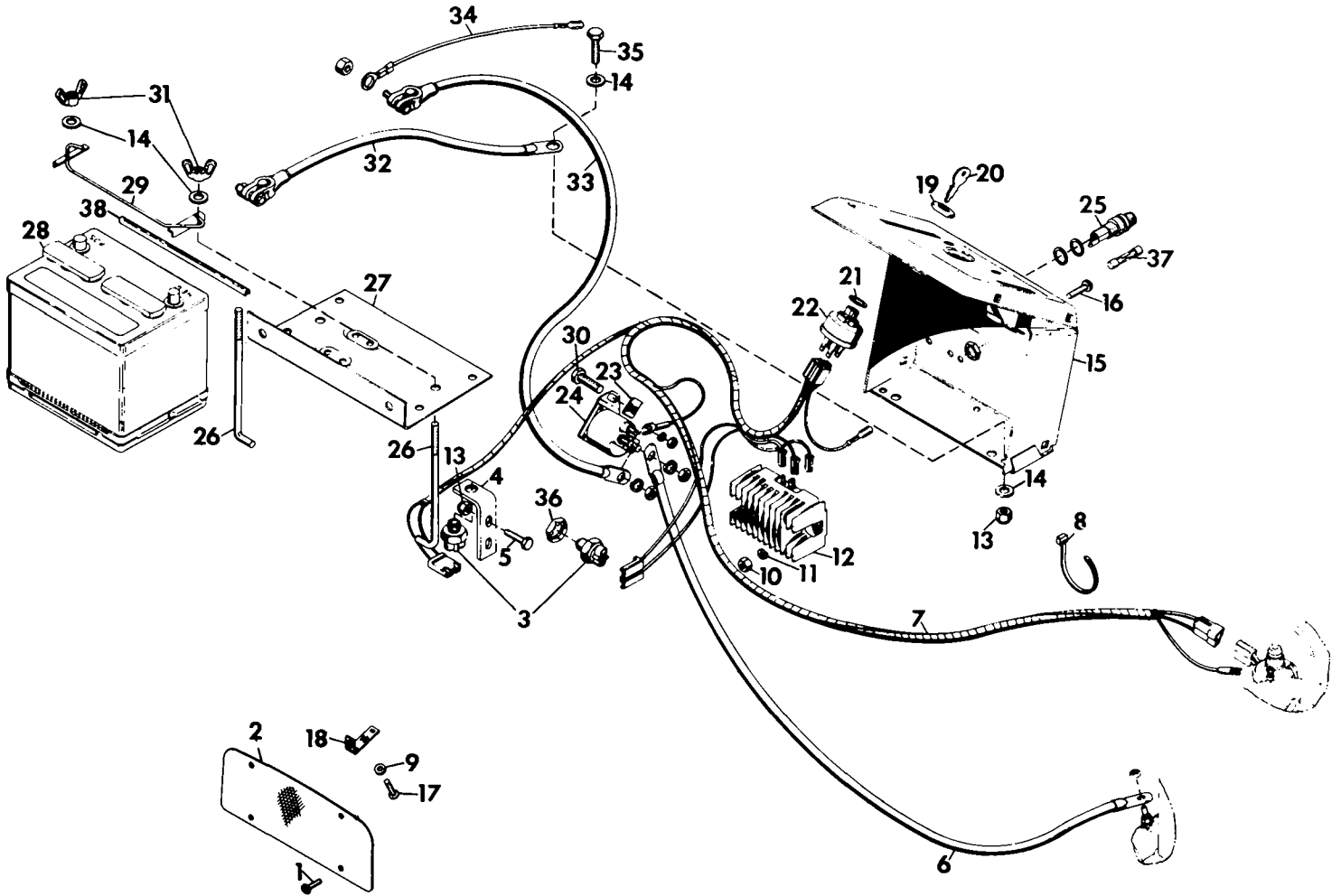

ITEM NO.	PART NO.	DESCRIPTION
1	159920	Screw, Machine; 10-24 x 1/2 Pan HD. C-Recess
2	11288P1	Panel, Front
3	20916P1	Switch, Interlock
4	20660P1	Bracket, Switch
5	180021	Bolt, Hex; 1/4-20 x 7/8
6	11031P1	Cable, Starter
7	20690P1	Harness, Wiring; 810, 812, 816S
8	10629P1	Tie, Cable
9	120385	Washer, Flat; 3/16 x 9/16 x .049
10	120375	Nut, Hex; 1/4-20
11	120380	Washer, Lock; 1/4 SP
12	18009P1	Regulator, Rectifier
13	9419454	Nut, Lock; 1/4-20 Washer Insert
14	120392	Washer, Flat; 9/32 x 5/8 x .065
15	21455A1	Weldment, Instrument Panel; 810, 812, 816S
16	160541	Screw, Machine; 1/4-20 x 3/4 Pan HD.
17	159947	Screw, Machine; 10-24 x 3/4 Pan HD. C-Recess
18	11030P1	Clip, Light MTG.
19	19666P1	Nut, Jam; 9/16-24
20	18570P1	Key, Ignition
21	19667P1	Washer, Lock; 9/16 Internal Tooth
22	19223P1	Switch, Ignition
23	11676P1	Nut, Speed; 1/4-20
24	7277P1	Switch, Magnetic
25	21416P1	Fuse, Panel
26	12386P1	Hook, Battery
27	18573P1	Tray, Battery
28	7274P1	Battery, 12 Volt
29	11027P1	Bracket, Battery Hold Down
30	180018	Bolt, Hex; 1/4-20 x 5/8
31	10413P1	Nut, Wing; 1/4-20 Washer Insert
32	6980P1	Cable, Battery; Negative
33	12375P1	Cable, Battery To Magnetic Switch
34	21425P1	Wire, Instrument Panel
35	180020	Bolt, Hex; 1/4-20 x 3/4
36	107354	Nut, Stamped; 9/16-18 7/8 x .20 Hex
37	14893P1	Fuse, 30 AMP; ACC 30
38	14897P1	Mounting

ELECTRICAL SYSTEM 812

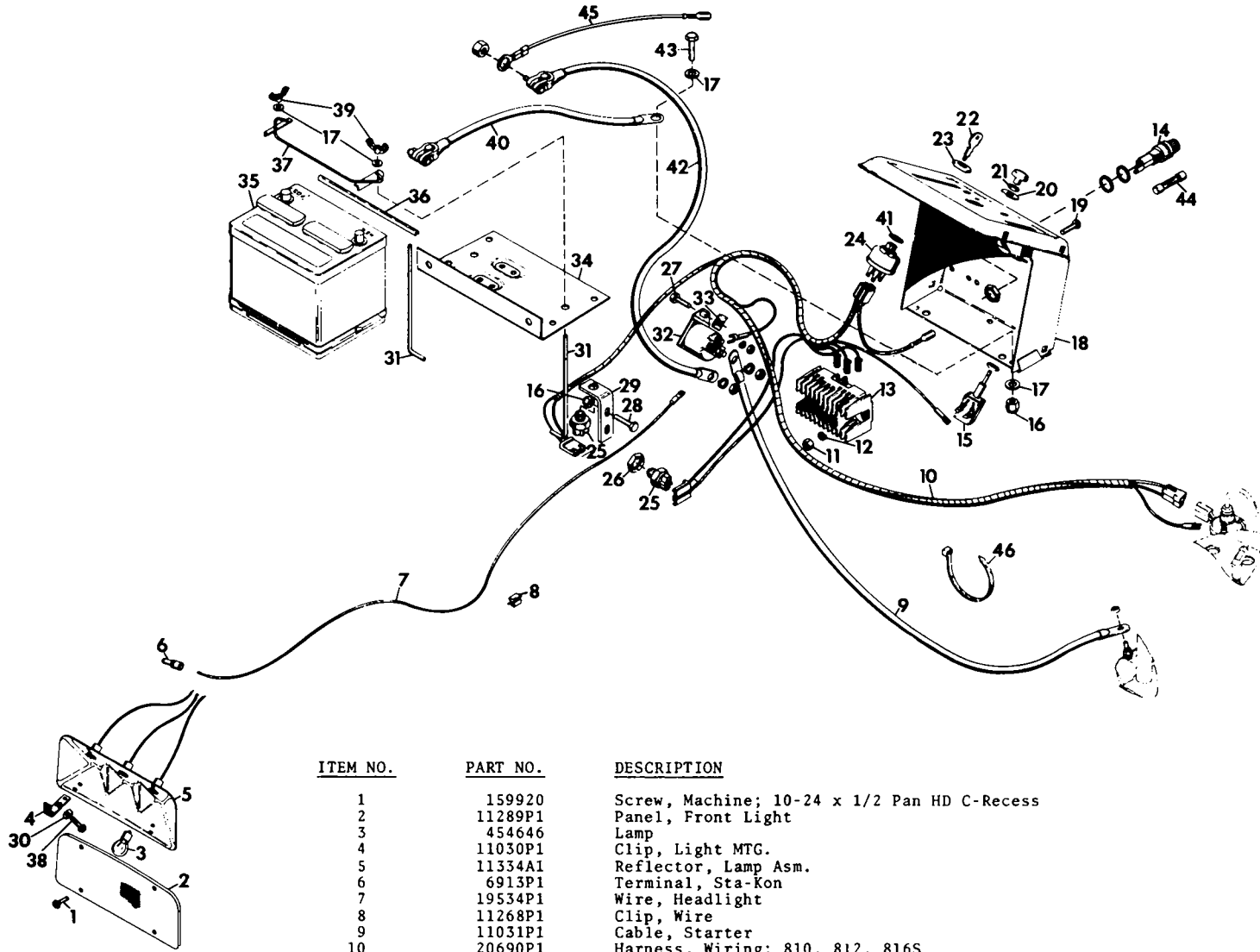

ITEM NO.	PART NO.	DESCRIPTION
1	159920	Screw, Machine; 10-24 x 1/2 Pan HD C-Recess
2	11289P1	Panel, Front Light
3	454646	Lamp
4	11030P1	Clip, Light MTG.
5	11334A1	Reflector, Lamp Asm.
6	6913P1	Terminal, Sta-Kon
7	19534P1	Wire, Headlight
8	11268P1	Clip, Wire
9	11031P1	Cable, Starter
10	20690P1	Harness, Wiring; 810, 812, 816S
11	120375	Nut, Hex; 1/4-20
12	120380	Washer, Lock; 1/4 SP
13	18009P1	Regulator, Rectifier
14	21416P1	Fuse, Panel
15	11337P1	Switch, Light
16	9419454	Nut, Lock; 1/4-20 Washer Insert
17	120392	Washer, Flat; 9/32 x 5/8 x .065
18	21455A1	Weldment, Instrument Panel; 810, 812, 816S
19	160541	Screw, Machine; 1/4-20 x 3/4 Pan HD
20	120388	Washer, Flat; 7/16 x 1 x .083
21	18587P1	Nut, Special
22	18570P1	Key, Ignition
23	19666P1	Nut, Jam; 9/16-24
24	19223P1	Switch, Ignition
25	20916P1	Switch, Interlock
26	107354	Nut, Stamped; 9/16-18 7/8 x .20
27	180018	Bolt, Hex; 1/4-20 x 5/8
28	180021	Bolt, Hex; 1/4-20 x 7/8
29	20916P1	Bracket, Switch
30	120385	Washer, Flat; 3/16 x 9/16 x .049
31	12386P1	Hook, Battery
32	7277P1	Switch, Magnetic
33	11676P1	Nut, Speed; 1/4-20
34	18573P1	Tray, Battery
35	7274P1	Battery, 12 Volt
36	14897P1	Moulding
37	11027P1	Bracket, Battery Hold Down
38	159947	Screw, Machine; 10-24 x 3/4 Pan HD C-Recess
39	10413P1	Nut, Wing; 1/4-20 Washer Insert
40	6980P1	Cable, Battery; Negative
41	19667P1	Washer, Lock; 9/16 Internal Tooth
42	12375P1	Cable, Battery To Magnetic Switch
43	180021	Bolt, Hex; 1/4-20 x 3/4
44	14893P1	Fuse, 30 AM; Acc 30
45	21425P1	Wire, Instrument Panel
46	10629P1	Tie, Cable

ELECTRICAL SYSTEM 816S

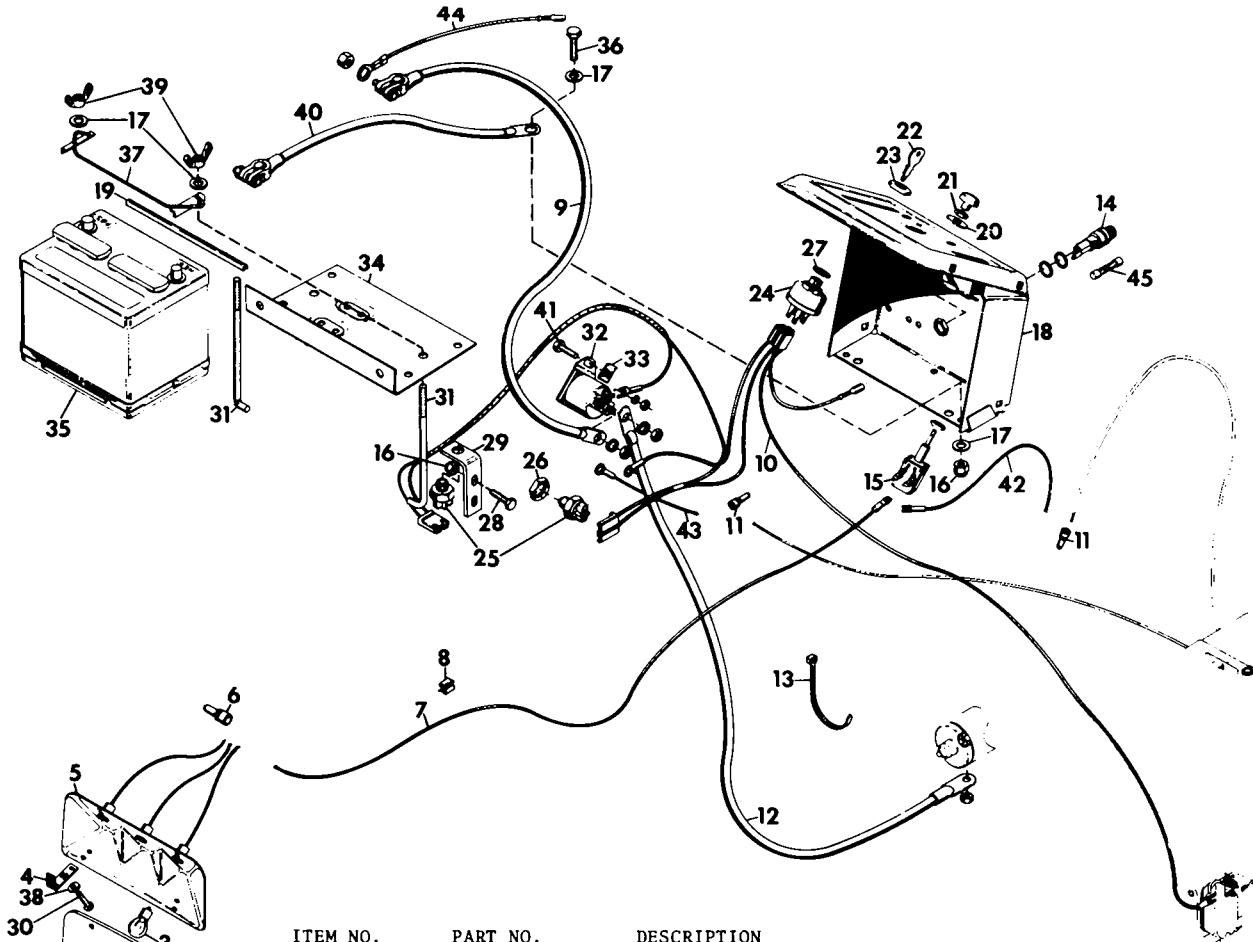

ITEM NO.	PART NO.	DESCRIPTION
1	159920	Screw, Machine; 10-24 x 1/2 Pan HD C-Recess
2	11289P1	Panel, Front Light
3	454646	Lamp
4	11030P1	Clip, Light MTG.
5	11334A1	Reflector, Lamp Asm.
6	6913P1	Terminal, Sta-Kon
7	19534P1	Wire, Headlight
8	11286P1	Clip, Wire
9	12375P1	Cable, Battery To Magnetic Switch
10	20750P1	Harness, Wiring; 816S
11	11763P1	Nut, Wire
12	20577P1	Cable, Starter
13	10629P1	Tie, Cable
14	21416P1	Fuse, Panel
15	11337P1	Switch, Light
16	9419454	Nut, Lock; 1/4-20 Washer Insert
17	120392	Washer, Flat; 9/32 x 5/8 x .065
18	18316A1	Weldment, Instrument Panel; 810, 812, 816S
19	14897P1	Moulding
20	120388	Washer, Flat; 7/16 x 1 x .083
21	18587P1	Nut, Special
22	18570P1	Key, Ignition
23	19666P1	Nut, Jam; 9/16-24
24	20564P1	Switch, Ignition
25	20916P1	Switch, Interlock
26	107354	Nut, Stamped; 9/16-18 7/8 x .20
27	19667P1	Washer, Lock; 9/16 Internal Tooth
28	180021	Bolt, Hex; 1/4-20 x 7/8
29	20660P1	Bracket, Switch
30	159947	Screw, Machine; 10-24 Pan HD C-Recess
31	12386P1	Hook, Battery
32	7277P1	Switch, Magnetic
33	11676P1	Nut, Speed; 1/4-20
34	18573P1	Tray, Battery
35	7274P1	Battery, 12 Volt
36	180020	Bolt, Hex; 1/4-20 x 3/4
37	11027P1	Bracket, Battery Hold Down
38	120385	Washer, Flat; 3/16 x 9/16 x .049
39	10413P1	Nut, Wing; 1/4-20 Washer Insert
40	6980P1	Cable, Battery; Negative
41	180018	Bolt, Hex; 1/4-20 x 5/8
42	20777P1	Wire, Headlight 816S
43	20778P1	Wire, Solenoid
44	21425P1	Wire, Instrument Panel
45	14893P1	Fuse, 30 AMP; A.c. 30

ELECTRICAL SYSTEM 816T & 818T

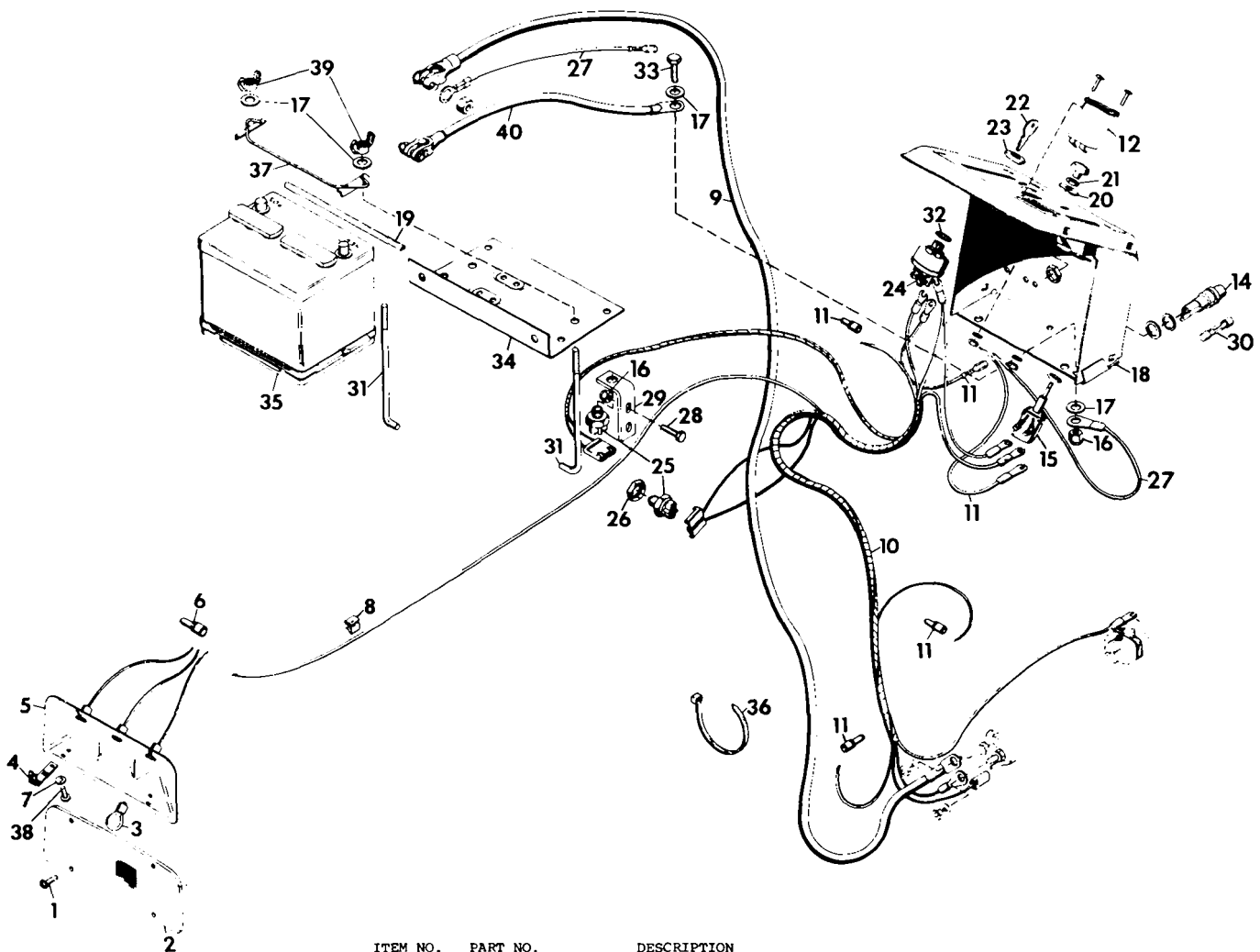

ITEM NO.	PART NO.	DESCRIPTION
1	159920	Screw, Machine; 10-24 x 1/2 Pan HD C-Recess
2	11289	Panel, Front Light
3	454646	Lamp
4	11030	Clip, Light MTG.
5	11334	Reflector, Lamp Assembly
6	6913	Terminal, Sta-Kon
7	120385	Washer, Flat; 3/16 x 9/16 x .049
8	11286	Clip, Wire
9	20889	Cable, Battery
10	23304	Harness, Wiring
11	11763	Nut, Wire
12	21426	Wire, Hourmeter
13	21414	Hourmeter
14	21416	Fuse, Panel
15	11337	Switch, Light
16	9419454	Nut, Lock; 1/4-20 Washer Insert
17	120392	Washer, Flat; 9/32 x 5/8 x .065
18	21432	Weldment, Instrument Panel; 817
19	14897	Moulding
20	120388	Washer, Flat; 7/16 x 1 x .083
21	18587	Nut, Special
22	18570	Key, Ignition
23	18585	Nut, Jam; 5/8-32
24	18207	Switch, Ignition
25	20916	Switch, Interlock
26	107354	Nut, Stamped; 9/16 x 18 7/8 x .20
27	21425	Wire, Instrument Panel
28	180021	Bolt, Hex; 1/4-20 x 7/8
29	20660	Bracket, Switch
30	14893	Fuse, 30 AMP; Acc 30
31	12386	Hook, Battery
32	18586	Washer, Lock; 5/8 Internal Tooth
33	180020	Bolt, Hex; 1/4-20 x 3/4
34	18573	Tray, Battery
35	7274	Battery, 12 Volt
36	10629	Tie, Cable
37	11027	Bracket, Battery Hold Down
38	159947	Screw, Machine; 10-24 x 3/4 Pan HD C-Recess
39	10413	Nut, Wing; 1/4-20 Washer Insert
40	6980	Cable, Battery; Negative

WIRING DIAGRAM 812

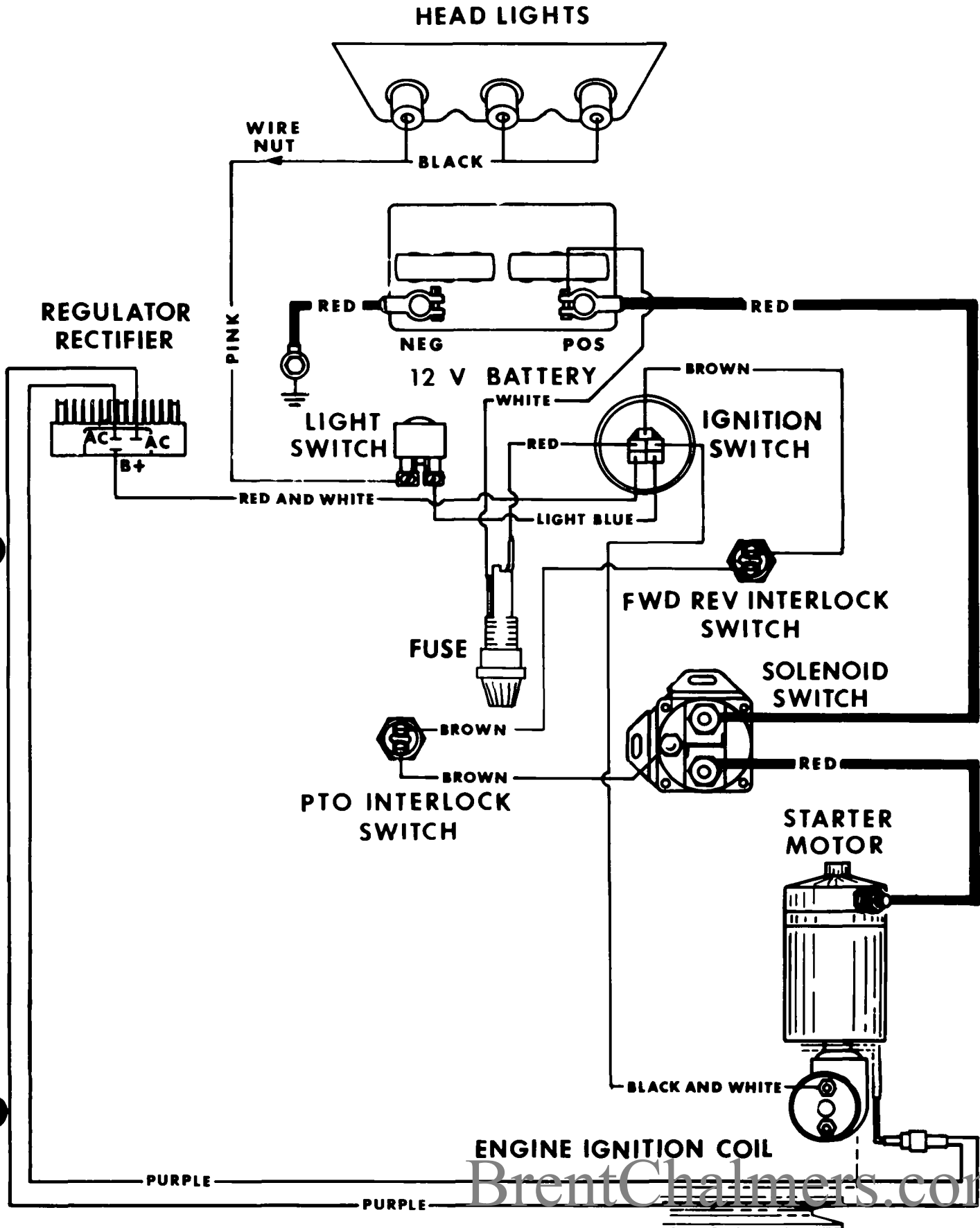

WIRING DIAGRAM 816 S

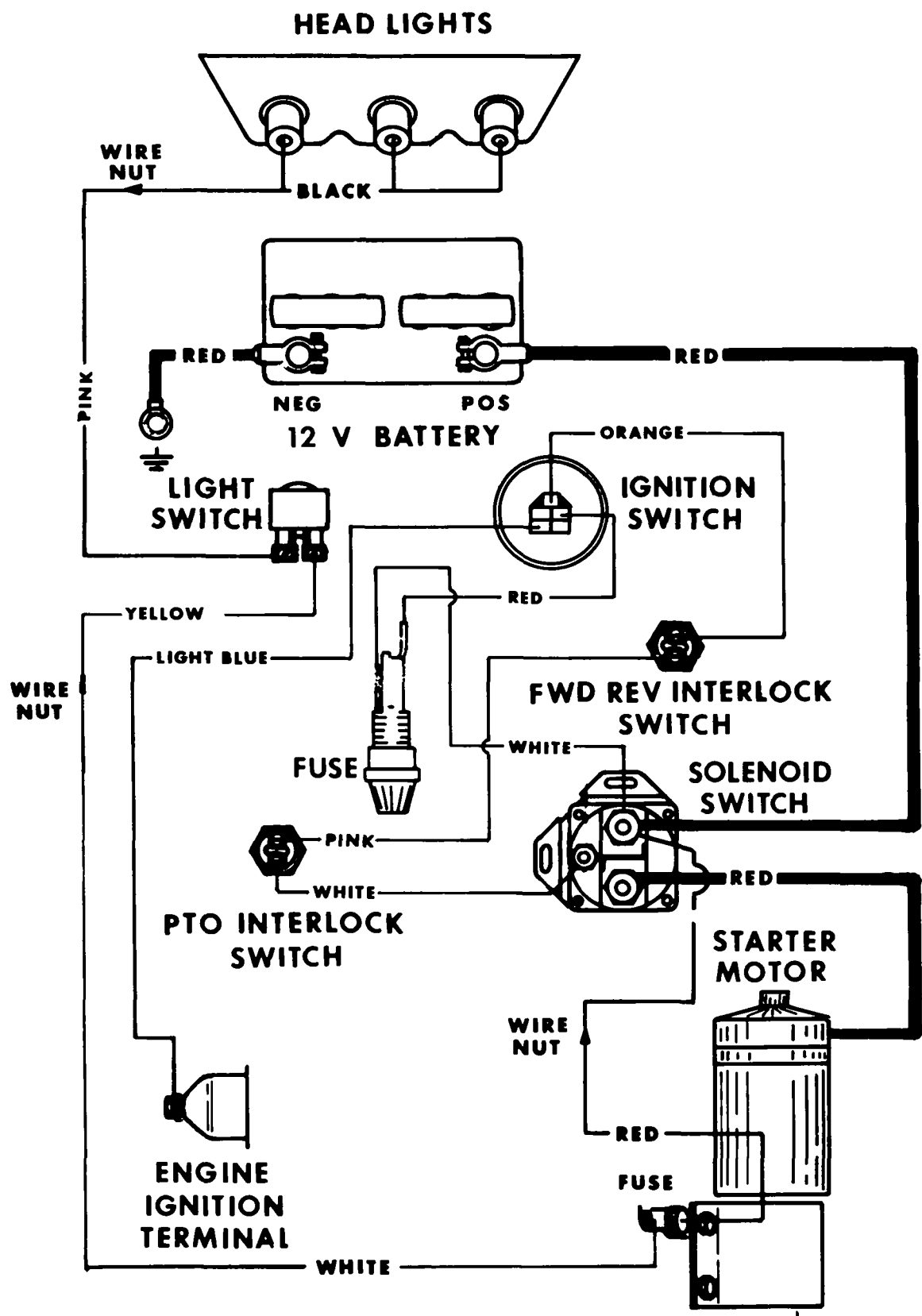

WIRING DIAGRAM 816T 818T

